

Moulding Manual

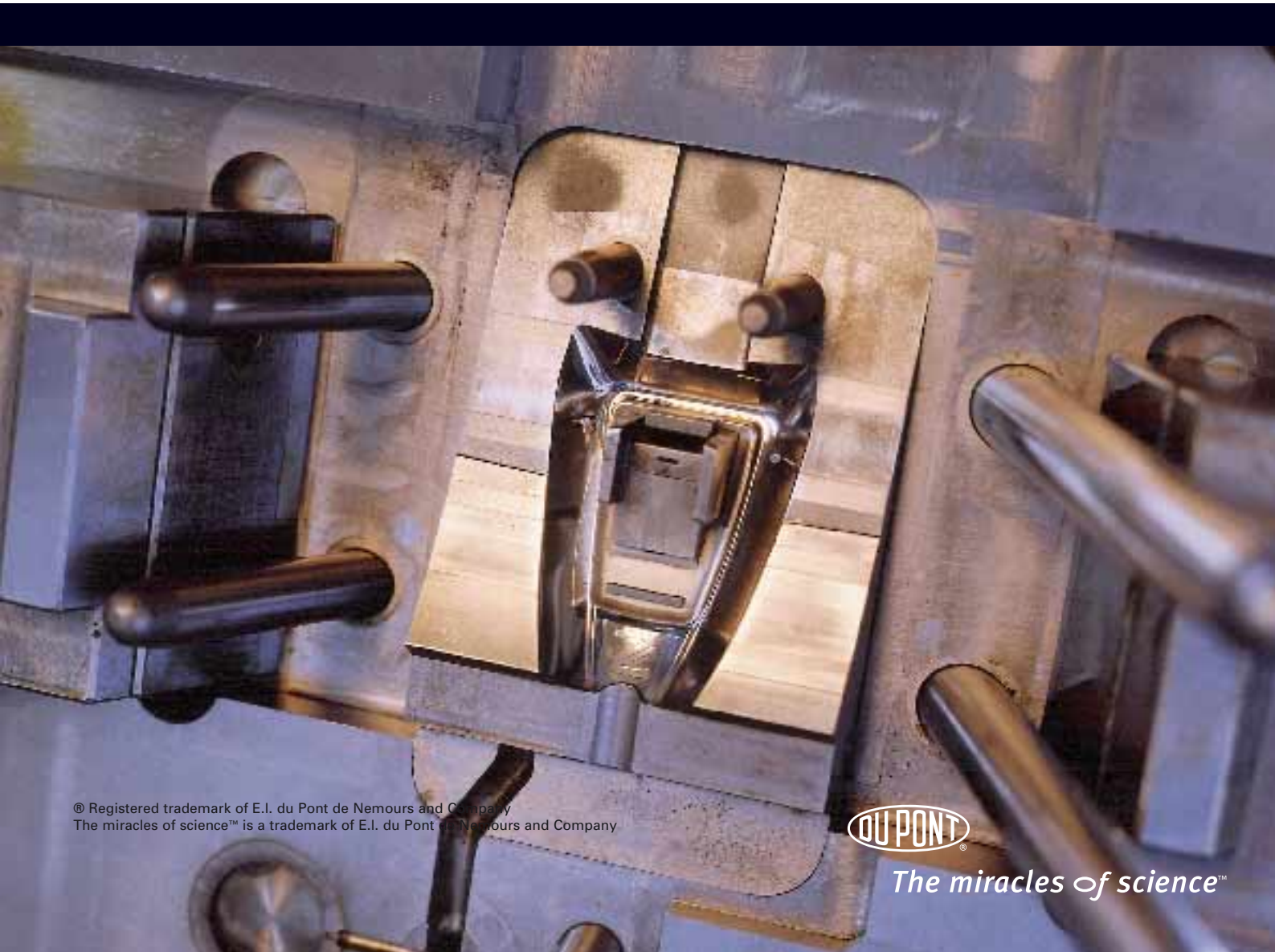

Moulding manual for DuPont DELRIN® acetal resin

Table of contents	Pages	Pages	
1. General information	1	5. Moulding process	25
Foreword	1	Start-up and shutdown procedures	25
Description	1	Operating conditions for DELRIN®	
Compositions	1	– temperature settings	25
Safety precautions to observe when moulding		Operating conditions for DELRIN®	
DELRIN® acetal resins	2	– moulding cycle	28
Packaging	3	Optimum productivity moulding	31
Recyclability of packaging waste	3	Standard moulding conditions	
2. Polymer structure and processing behaviour	5	for ISO tensile bars	32
Glass transition and melting	5	Appendix: Hold Pressure Time via in-cavity	
PVT diagrams	6	pressure measurement	32
Heating-cooling behaviour	7	6. Dimensional considerations	33
Viscosity and rheological behaviour	7	Mould shrinkage	33
3. Injection moulding unit	9	Factors affecting mould shrinkage	34
Screw design	10	Mould shrinkage of filled resins	35
Cylinder temperature control	11	Effect of pigments	35
Cylinder adaptor	11	Post-moulding shrinkage	36
Non-return valve (Back Flow Valve – BFV)	11	Insert moulding	36
Nozzle	12	Annealing	36
Evaluation of melt quality	12	Environmental changes	37
4. Moulds	15	Dimensional tolerances	37
Ability to fill	15	7. Auxiliary operations	39
Gates	16	Material handling	39
Runner system	18	Drying	39
Nozzle and sprue	19	Reground resin	40
Hot runner mould for crystalline polymers	20	Colouring	41
Vents	21	Disposal	41
Undercuts	22	8. Troubleshooting guide	43
Sharp corners	22	Simulated computer screens from CAMDO	45
Ribs design	23	9. Index	48
Weld lines	23	Insert: Processing data	Part II
Mould maintenance	23		
Mould cleaning	23		

1. General information

Foreword

This brochure presents a comprehensive description of the injection moulding process for DELRIN®. The objective is to better understand what occurs during this moulding process of a “crystalline polymer” and to provide processing guidelines.

In addition to the information included in the moulding guide, DuPont has developed a proprietary expert system called Computer Aided Moulding Diagnostic Optimization (CAMDO). Under guidance of the DuPont representative, it is possible to optimize the complete moulding process in an interactive way. For more information, please consult your DuPont representative.

Description

DELRIN® acetal resins are thermoplastic polymers made by the polymerization of formaldehyde. They have gained widespread recognition for reliability in many thousands of engineering components all over the world. Since commercial introduction in 1960, DELRIN® has been used in the automotive, appliance, construction, hardware, electronics, and consumer goods industries, among others.

DELRIN® is noted for:

- Toughness at low temperature (down to -40°C).
- High mechanical strength and rigidity.
- Fatigue endurance unmatched by other plastics.
- High resistance to repeated impacts .
- Excellent resistance to moisture, gasolines, solvents and many other neutral chemicals.
- Excellent dimensional stability.
- Natural lubricity.
- Resilience.
- Good electrical insulating characteristics.
- Ease of fabrication.
- Wide useful temperature range (in air: -50 to $+90^{\circ}\text{C}$, with intermittent use up to 140°C).

DELRIN® acetal resins are available in a variety of compositions to meet different end-use and processing requirements.

Compositions

The main available DELRIN® compositions can be classified as follows:

- a. Standard.
- b. Toughened.
- c. Low wear/Low friction.
- d. Glass filled.

The standard compositions cover a broad range of melt viscosities. The resin having lower melt viscosity, DELRIN® 900P, is usually chosen for injection moulding applications with hard-to-fill moulds. The intermediate melt viscosity DELRIN® 500 is used for general purpose injection applications. The highest viscosity composition, DELRIN® 100, is often moulded when maximum toughness properties are needed.

A summary of the main compositions is shown in Table 1.01.

Table 1.01 Main compositions of DELRIN® acetal resins

Low viscosity grades:

DELRIN® 900P

Characteristics: Low viscosity, fast moulding resin.

Typical applications: Multicavity moulds and parts with thin sections, e.g. consumer electronics parts, zippers.

DELRIN® 911P

Characteristics: DELRIN® 900P with enhanced crystallinity. Resistance to creep and fatigue endurance improved over DELRIN® 900P. Excellent resistance to gasoline, lubricants, solvents and many neutral chemicals.

Typical applications: Multicavity moulds and parts with thin sections, e.g. consumer electronic parts.

Medium viscosity grades:

DELRIN® 500

General purpose moulding resin with medium viscosity. Applications: general mechanical parts.

DELRIN® 500P

Same characteristics and applications as DELRIN® 500, plus best processing stability for deposit-free moulding in demanding processing conditions (e.g. hot runner tools).

DELRIN® 507

Same characteristics as DELRIN® 500, plus UV stabiliser. Applications: Mechanical parts like bicycles pedals, trim and building fittings requiring good mechanical properties in addition to resistance to ultraviolet light.

DELRIN® 527UV

Characteristics: DELRIN® 500P with maximum UV protection. Typical applications: Automotive parts with maximum UV performance requirements.

DELRIN® 511P

Characteristics: DELRIN® 500P with enhanced crystallinity. Typical applications: fuel system components, gears, fasteners.

High viscosity grades

DELRIN® 100

High viscosity moulding material.

Excellent tensile strength and resistance to creep over a wide temperature range, even under humid ambient conditions.

High fatigue endurance and impact resistance.

Applications: moulded parts such as highly loaded gears, plain bearings and snap-fits.

This summary reflects the information contained in Campus.

Table 1.01 Main compositions of DELRIN® acetal resins
(continued)

DELRIN® 100P	Same characteristics and applications as DELRIN® 100, plus best moulding stability for deposit free moulding in demanding processing conditions (e.g. hot runner tools).
DELRIN® 111P	Characteristics: DELRIN® 100P with enhanced crystallinity. Resistance to creep and fatigue endurance improved over DELRIN® 100P. Typical applications: Highly loaded gears, bearings, snap-fits.
DELRIN® 107	Same characteristics and applications as DELRIN® 100, plus UV-stabiliser.
DELRIN® 127UV	Characteristics: DELRIN® 100P with maximum UV protection. Applications: Automotive parts with maximum UV performance requirements.
Toughened grades	
DELRIN® 100ST	Super Tough. High viscosity, super tough material for injection moulding, extrusion and blow moulding. Excellent combination of super-toughness, impact fatigue resistance, wear resistance, solvent and stress crack resistance, as well as high tensile elongation at low temperature. Applications: Mainly used for parts requiring resistance to repeated impacts and loads, such as automotive fasteners, helmets, hoses and tubing.
DELRIN® 100T	Characteristics: Toughened high viscosity resin, low friction partner to DELRIN® 100/500 in gear applications. Applications: Fasteners, seats belt restraint systems, gears.
DELRIN® 500T	Lubricated. Medium viscosity resin for injection moulding, extrusion and blow moulding. Excellent notched Izod and tensile impact strength. Applications: Mainly used for parts subjected to repeated impacts and alternating loads, such as automotive fasteners, helmets, hoses and tubing.
Low friction/low wear grades	
DELRIN® 500AF	PTFE-filled. Medium viscosity resin containing TEFLON® PTFE fibres for injection moulding and extrusion. Very low coefficient of friction, high resistance to abrasion and wear. Applications: Where low coefficient of friction, high resistance to abrasion and wear are required such as in bearings.
DELRIN® 500CL	Chemically lubricated. Medium viscosity resin containing chemical lubricant for injection moulding and extrusion. Applications: Where abrasion characteristics superior to 500 and equivalent mechanical properties are needed such as in highly loaded bearings.
Glass filled grades	
DELRIN® 570	Filled with 20% glass fibre. Moulding resin with medium viscosity, filled with glass fibre. Applications: Where high stiffness and creep resistance are required.

Safety precautions to observe when moulding DELRIN® acetal resins

DELRIN® as well as many other thermoplastic polymers decomposes to gaseous products when heated for a prolonged time. These gases can generate high pressures if confined. If material is not free to exit from an injection cylinder through the nozzle, it may blow back through the hopper.

In the case of DELRIN® acetal resin, decomposition is almost entirely to gaseous products, so pressure build-up can be rapid. The product of decomposition is formaldehyde.

When moulding DELRIN®, it is important that the operator be familiar with the factors that can cause decomposition, with the danger signals that warn of this problem, and with the action that should be taken. This information is summarised on a card for display at the moulding machine.

The information given here is based on our experience to date. It may not cover all possible situations and it is not intended as a substitute for skill and alertness of the operator.

Follow correct start-up, operating and shut-down procedures as described later in this manual (Chapter 5).

Be aware of troublemakers – causes of decomposition

- High temperature – sticking temperature controller, faulty thermocouple connections, incorrect reading, burned-out heater or heater with a hot spot, heat surges on start-up.
- Cycle delay.
- Hold-up areas – in cylinder, adapter, nozzle, screw tip, hot runner and check valve assembly.
- Plugged nozzle – from scrap metal or higher melting point resin, or from closed nozzle valve.
- Foreign materials.
Additives, fillers or colourants other than those specifically recommended for use in DELRIN®.
Contaminants (especially those containing chlorine or generating acid materials) such as polyvinylchloride resin or flame retardants.
Copper, brass, bronze or other copper alloys in contact with molten DELRIN® (not in moulds where the resin solidifies after each cycle).
Copper-based lubricants or grease for threads.
Contaminated rework – especially rework or reprocessed resin from outside or unknown sources.

Watch for danger signals

- Frothy nozzle drool.
- Spitting nozzle.
- Pronounced odour.
- Discoloured resin – brown or black streaking.
- Badly splayed parts – whitish deposit on moulding or mould.
- Screw push back from gas pressure.

Action required when any of the danger signals occur

- **AVOID PERSONAL EXPOSURE** – When DANGER SIGNALS are present, DO NOT look into hopper or work around nozzle as violent ejection of melt is possible.
- **MINIMISE PERSONAL EXPOSURE TO DECOMPOSITION GASES** by using general and local ventilation. If necessary, leave area of machine until ventilation has reduced concentration of formaldehyde to acceptable levels. Persons sensitised to formaldehyde or having existing pulmonary disabilities should not be involved in processing DELRIN®.
- **FREE NOZZLE PLUG** by heating with torch. If this fails, cool down cylinder, make sure PRESSURE IS RELIEVED, and CAREFULLY REMOVE NOZZLE and clean.
- **TAKE AIR SHOTS** to cool the resin – PURGE WITH CRYSTAL POLYSTYRENE. DROP ALL MOLTEN DELRIN® INTO WATER to reduce odour level.
- Turn off cylinder heaters.
- Check temperature control instruments.
- Discontinue automatic moulding and run manually until job is running smoothly.
- Provide adequate means of venting feed mechanism in case of blowback.
- Use exhaust ventilation to reduce formaldehyde odour.

See current Material Safety Data Sheet (MSDS) for health and safety information. To obtain a current MSDS, call your DuPont representative.

Packaging

DELRIN® acetal resin is supplied as spherical or cylindrical pellets approximately 3 mm in dimensions. They are packaged in 1000 kg net weight bulk corrugated boxes or 25 kg moisture protected, tear resistant polyethylene bags. The bulk density of the unfilled resin granules is about 0,8 g/cm³.

Recyclability of packaging waste

• Polyethylene bags 25 kg:

Polyethylene bags are recyclable, if the package is completely emptied. Bags are marked with the recycling symbols (Fig 1.01)

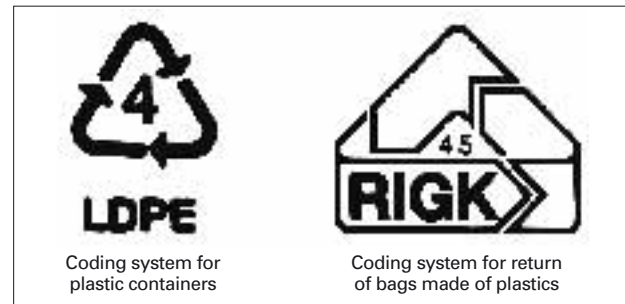

Fig. 1.01 Coding systems

• Standard CP6 pallet:

The VCI (Verband der Chemischen Industrie Germany) and the APME (Association of Plastics Manufacturers Europe) approved the CP6 pallets (1000 × 1200 × 160 mm), see Fig. 1.02. Free collection of these pallets by a third party for reuse after reconditioning is offered in Germany and a similar arrangement may soon be enacted in other European countries.

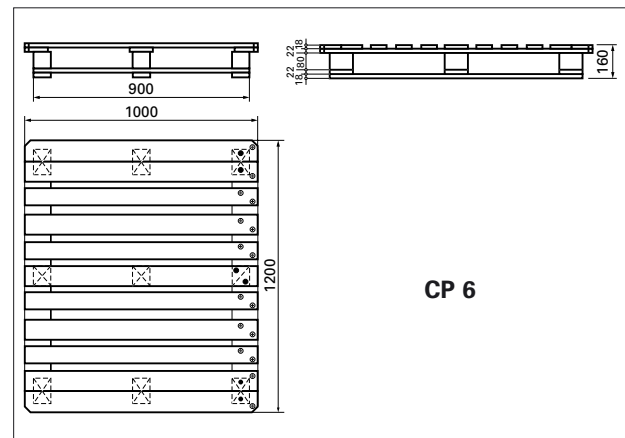

Fig. 1.02 CP6 pallet

• Polyethylene stretchfoil, cartons:

Polyethylene stretchfoil and cartons are recyclable and also properly marked with the recycling symbols (Fig. 1.03).



Fig. 1.03
"Resy" recyclability
symbol

2. Polymer structure and processing behaviour

The behaviour of a polymer during the moulding process and the behaviour of a moulded part during its whole end-use life are highly dependent on the type of structure that the polymer tends to form during solidification.

Some polymers exhibit in the solid state roughly the same molecular arrangement as in the melt, i.e., a random mass of entangled molecules with no order. This class is named “amorphous polymers” and includes for example ABS, polycarbonate and polystyrene.

Other polymers tend to solidify in an ordered manner: the molecules arranging into crystalline forms (lamellae, spherulites). Because of the length of the macromolecules, parts of them cannot belong to crystals (due to lack of space and mobility) and create an amorphous inter-crystalline zone. These polymers are therefore “partially crystalline” or “semi-crystalline”; for simplicity, in this text we will refer to them as “crystalline” (in opposition to “amorphous”).

Typical crystalline materials are DELRIN® (acetal resins), ZYTEL® (polyamide resins), RYNITE® PET and CRASTIN® PBT (thermoplastic polyester resins), polyethylene and polypropylene.

Table 2.01 summarizes some fundamental differences between amorphous and crystalline polymers. These points are described in more detail in the following paragraphs. This information is essential to understand why the optimisation of the moulding process is substantially different for the two categories of polymers.

Table 2.01 Comparison of amorphous and crystalline polymers

Resin type	Amorphous	Crystalline
Properties		
Thermal parameters	T_g	T_g, T_m
Maximum T in use ¹⁾	Below T_g	Below T_m
Specific volume vs. T	Continuous	Discontinuity at T_m
Melt viscosity vs. T	High dependence	Low dependence
Processing		
Solidification	Cooling below T_g	Crystallisation below T_m
Hold pressure	Decreased during cooling	Constant during crystallisation
Flow through gate	Stops after dynamic filling	Continues until end of crystallisation
Defects if bad process	Over-packing, stress-cracking, sink marks	Voids, deformations, sink marks

1) For typical engineering applications

Glass transition and melting

Amorphous polymers

The overall behaviour of amorphous polymers is largely determined in relation to their glass transition temperature T_g .

Below this temperature, the molecules are essentially blocked in the solid phase. The material is rigid and has a high creep resistance, but it also tends to be brittle and sensitive to fatigue.

When the temperature is increased above the glass transition temperature T_g , the molecules have some freedom to move by rotation around chemical bonds.

The rigidity decreases gradually and the material shows elastomeric properties, lending itself to processes like thermoforming, blow moulding and (at temperatures 120-150° C above T_g) injection moulding.

Amorphous polymers used in engineering applications have T_g above the ambient temperature, and the maximum temperature for end-use should be below T_g ; for example polystyrene has $T_g = 90-100^\circ\text{C}$, and is injection moulded between 210 and 250° C.

Crystalline polymers

In crystalline polymers, the onset of molecular movement in the material also defines the glass transition temperature T_g .

When the temperature is increased above T_g , the crystalline polymers maintain rigidity appropriate for engineering applications (for example with DELRIN® a part can easily withstand temperatures 150° C above T_g).

Upon further heating the material reaches its melting temperature T_m , where the cohesion of the crystalline domains is destroyed. Within a few degrees, there is a considerable change of mechanical properties from solid to liquid behaviour. Above T_m , the crystalline polymers behave as high viscosity liquids, and can generally be processed by injection moulding, typically at temperatures 40-60° C above their melting temperature. As a consequence, the temperature domain for the use of crystalline polymers is not limited by the glass transition temperature T_g , but by the melting temperature T_m . For DELRIN®, $T_g = -60^\circ\text{C}^*$, $T_m = 175^\circ\text{C}$ and the typical processing range is 210-230° C.

* Some authors attribute the onset of molecular movement at -60°C in DELRIN® to a “crankshaft” rotation in the crystalline domains (involving 2-3 repeat units), and they reserve the term “glass transition” to the onset of collective movements of 20-80 repeat units in amorphous zones, which is claimed to occur at -13°C . In typical injection-moulded parts of DELRIN® the crystallinity is so high that there are few such long segments in amorphous zones, and the transition at -13°C is hardly observed. However the transition at -60°C always appears, and the behaviour of parts at -30°C corresponds well to molecular mobility. So for practical purposes it can be said that DELRIN® has a T_g at -60°C .

PVT diagrams

The PVT diagram is a condensed presentation of the inter-relations of three variables that affect the processing of a polymer: Pressure, Volume and Temperature.

The effect of the temperature (T) or volume (V) is illustrated in Fig. 2.01 for an amorphous and a crystalline polymer.

When the temperature of the material is increased, its specific volume (the inverse of density) also increases due to thermal expansion.

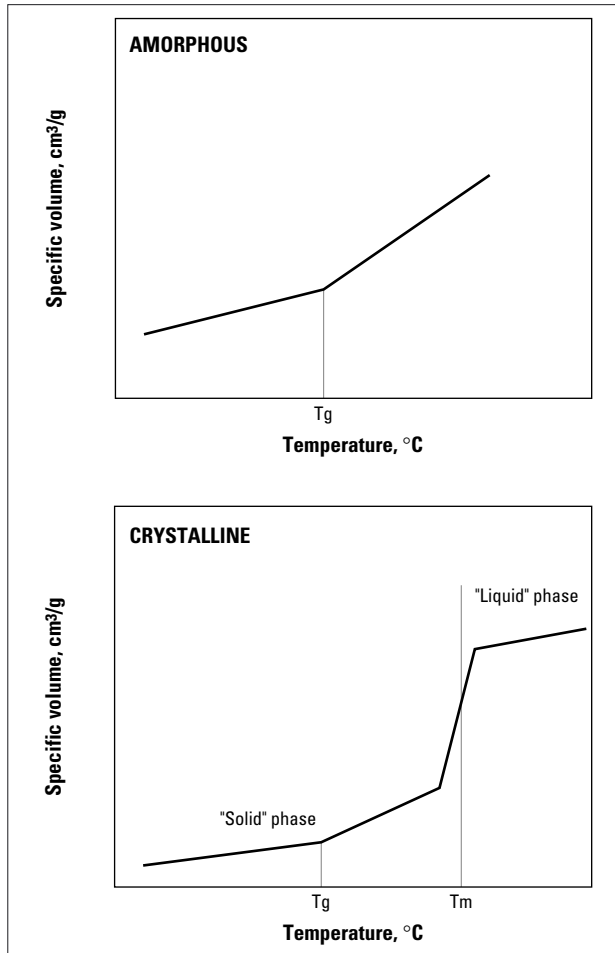

Fig. 2.01 Specific volume as function of temperature for amorphous and crystalline polymers

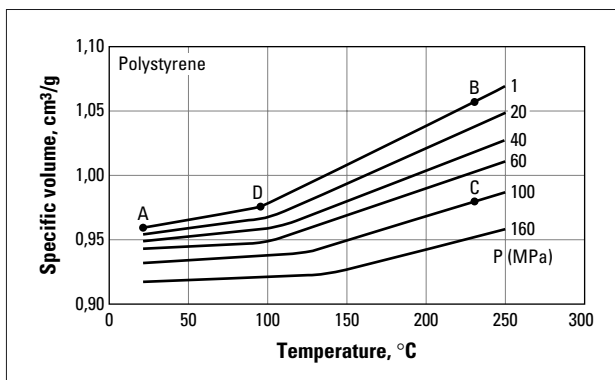

Fig. 2.02 PVT (Pressure-Volume-Temperature) diagram for polystyrene. Points A, B, C and D refer to different steps of the moulding process (see text)

The rate of increase becomes higher at the glass transition temperature, because the molecules have more freedom to move and they occupy more space. This change of slope is observed with both amorphous and crystalline polymers.

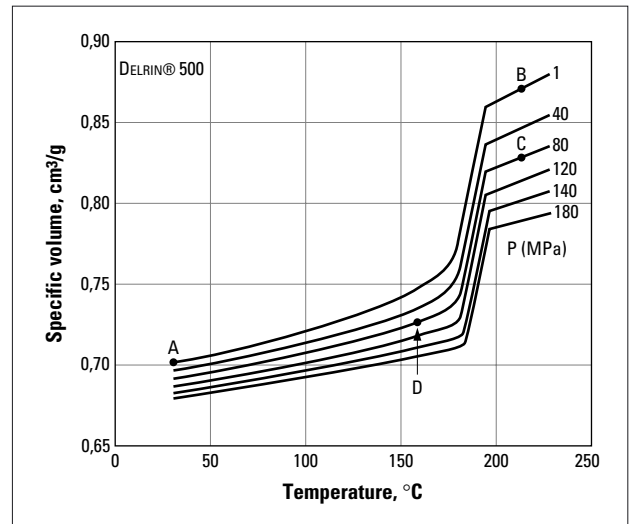

Fig. 2.03 PVT (Pressure-Volume-Temperature) diagram for DELRIN® 500. Points A, B, C and D refer to different steps of the moulding process (see text)

At higher temperature, the melting of crystalline polymers is marked by a sudden increase of the specific volume, when the well-ordered and rigid crystalline domains become randomly oriented and free to move. The specific volume is therefore a signature of the changes of structure of the polymer as a function of temperature.

A PVT diagram is simply the presentation of the series of curves obtained when the measurement of specific volume versus temperature is repeated at different pressures. The PVT diagram of a typical amorphous polymer (polystyrene) is shown as Fig. 2.02, and the PVT diagram of DELRIN® is shown as Fig. 2.03.

The moulding process can be illustrated by a cycle of transitions on the PVT diagram. For simplification, it will be assumed in the following description that heating takes place at constant pressure ("along isobar lines") and that application of pressure is isothermal (vertical lines).

For an amorphous material the moulding cycle is as follows (see Fig. 2.02):

- starting from room temperature and 1 bar pressure (point A) the material is heated in the barrel. The specific volume increases according to the isobar at 1 bar to reach the moulding temperature (point B).
- the material is injected into the cavity and the pressure is applied. This process is roughly isothermal

(to point C), and the specific volume is decreased to a value close to that at 1 bar and T_g .

- the resin is cooled in the mould, and at the same time the hold pressure is decreased, to follow a horizontal line in the PVT diagram and reach point D where the part can be ejected when it is at 1 bar pressure and a temperature below T_g . Ideally, there should be no flow of material through the gate during this cooling phase to produce a stress-free part.

For a crystalline material, the picture is different (see Fig. 2.03):

- the material is heated at 1 bar pressure from room temperature (point A) up to the processing temperature (point B). This results in a large change of volume (almost 25% for DELRIN®);
- the resin is injected and compressed in the cavity. The specific volume is decreased to point C, where its value is still much higher than at 1 bar/ 23°C;
- crystallisation takes place in the mould under constant hold pressure. When the crystals build-up from the liquid phase, a large difference of volume occurs, which must be compensated by injection of additional liquid resin through the gate (otherwise voids are created within the part);
- at the end of crystallisation (point D), the part is solid and it can be ejected immediately; the moulding shrinkage is the difference between the specific volumes at the crystallisation temperature (point D) and at room temperature (point A).

This difference in behaviour has important implications for injection moulding. During the solidification process (after dynamic filling):

- the hold pressure is decreased with time for amorphous polymers, whereas it is maintained constant for crystalline polymers;
- the flow through the gate is stopped for amorphous polymers, while it continues until the end of the crystallisation for crystalline polymers. This implies that for crystalline materials the design of parts, gates, runners and sprue should follow special rules that will be described in chapter 4.

Heating-cooling behaviour

For any substance, the energy needed to increase the temperature of 1 g material by 1°C is defined as its specific heat. This quantity is generally determined by Differential Scanning Calorimetry, and the results for DELRIN®, polyamide 66 and polystyrene are shown in Fig. 2.04. The two crystalline polymers, DELRIN® and polyamide 66, show a large peak that is due to the additional heat required to melt the crystalline phase (latent heat of fusion). The amorphous polymer

does not show such a peak, but exhibits a change of slope at T_g .

The total energy to bring each material up to its moulding temperature is given by the area under the curve. From Fig. 2.04 it is clear that the crystalline polymers need more energy than the amorphous ones. This explains why the design of a screw for a crystalline polymer like DELRIN® should be different (and usually more critical) than for an amorphous polymer.

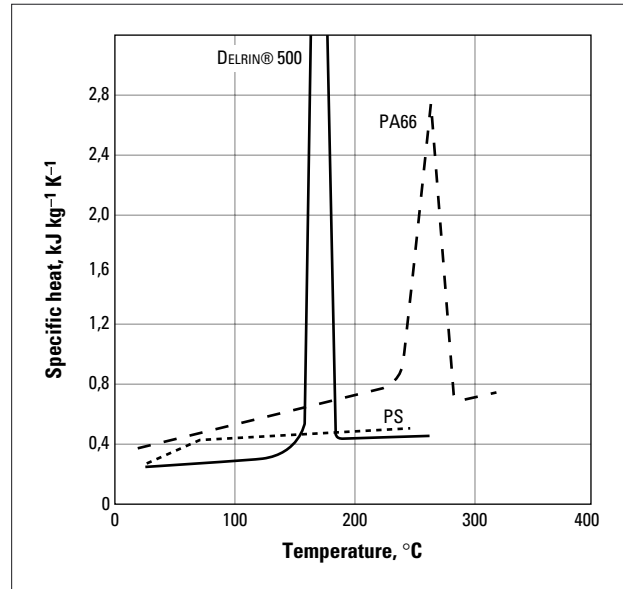

Fig. 2.04 Specific heat versus temperature for DELRIN® 500, PA66 and polystyrene

Viscosity and rheological behaviour

Melt viscosity determines to a large extent the ability to fill the mould cavity. High viscosity means difficult flow through thin sections and higher injection fill pressure.

Temperature and shear rate are crucial parameters when considering the viscosity of molten polymers, and they should always be specified together with a value for melt viscosity.

For polymers consisting of linear molecules like DELRIN®, the viscosity is also in direct relation to the average molecular weight.

Influence of temperature

The general rule that liquids become less viscous when increasing temperature is also true for molten thermoplastics. However crystalline and amorphous polymers behave differently, as shown in Fig. 2.05. The curves for DELRIN® and polystyrene were both obtained by reducing gradually the temperature of the materials from 230 to 100°C. Two differences are worth mentioning.

First, at temperatures above 180° C, the dependence of viscosity on temperature is more pronounced for the amorphous polystyrene than for DELRIN®; therefore, increasing the melt temperature of DELRIN® does not greatly improve its ability to flow through a thin section. Second, below 170° C the viscosity of DELRIN® rises sharply because the material crystallises within a few degrees of temperature.

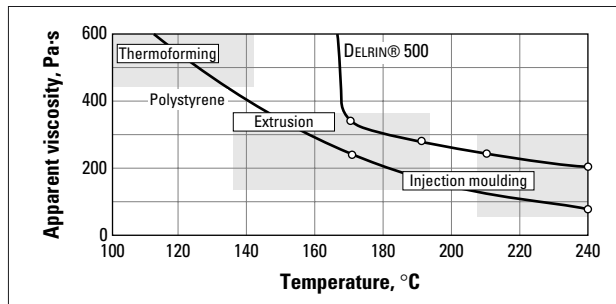

Fig. 2.05 Viscosity/temperature curves for DELRIN® 500 and for polystyrene at a constant shear rate of 1000 s⁻¹ (temperature reduced from 230 to 100° C)

Influence of shear rate

The shear rate characterises the rate of deformation of the material and is defined as the derivative of the velocity over the direction perpendicular to flow (see Fig. 2.06); in other words, the shear rate is proportional to the variation of speed within the part thickness. So it depends on the velocity of the flow and on the geometry of the flow channels.

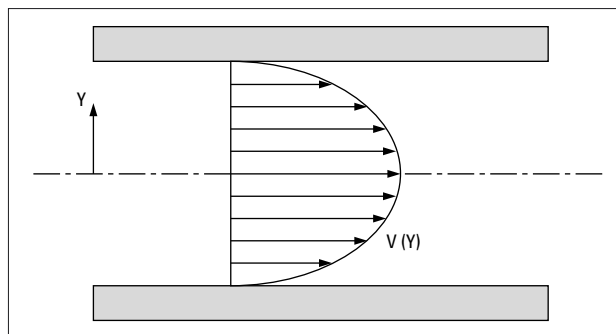

Fig. 2.06 Approximate shape of the velocity distribution between two parallel plates. The shear rate is the derivative $dv(y)/dy$

For DELRIN®, the melt viscosity decreases considerably when the shear rate increases, as shown in Fig. 2.07. This effect is more important than the differences resulting from variations of the melt temperature within the processing window for injection moulding.

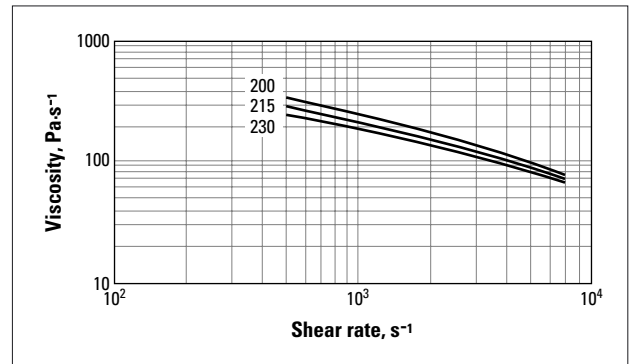

Fig. 2.07 Viscosity vs. shear rate of DELRIN® 500 NC010 at 3 temperatures (source: Campus)

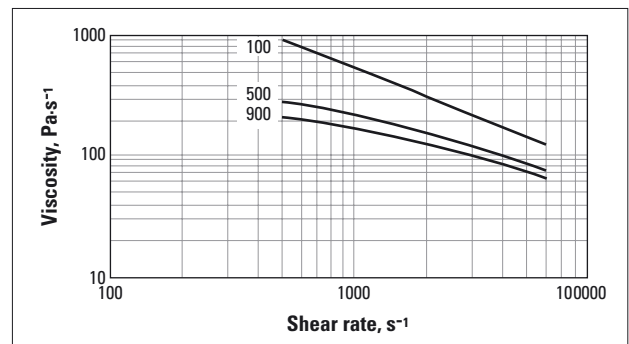

Fig. 2.08 Viscosity vs. shear rate for various grades of DELRIN®, at a constant temperature of 215° C (source: Campus)

Influence of molecular weight

DELRIN® is available in four grades of molecular weight. They are coded according to their ability to flow, as measured by MFR (see Table 2.02). High values mean easy flow and ability to fill thin parts, whereas low values mean high viscosity, high molecular weight and high toughness (impact resistance, elongation at break).

MFR is a measurement performed at low shear rate, but the relative differences between the grades are maintained at high shear rates, as shown in Fig. 2.08.

A more direct comparison of the ability to fill can be obtained using an open-ended snake-flow mould. Results for the different grades of DELRIN® are presented in chapter 4.

Table 2.02 Viscosity, flow and molecular weight of the DELRIN® grades

Grade	MFR (190°C/2,16 kg)	Ease of flow	Molecular weight, toughness	Spiral flow length (215°C/100 MPa/ 2 mm) 90°C mould temp.
100	2,2 g/10 min	lowest	highest	170 mm
500	14 g/10 min	↓	↓	295 mm
900	25 g/10 min	highest	lowest	350 mm

3. Injection moulding unit

DELTRIN® acetal resins are moulded throughout the world in a wide variety of types and designs of injection and extrusion equipment.

The first purpose of the injection unit for moulding a crystalline material is to deliver to the mould the necessary amount of a homogeneous melt (with no unmelt and no degraded material). The rules of construction of the injection unit are then dependent on the moulding material requirements in term of thermal behaviour and heat needed. The first point to take into account for a crystalline material is the thermal stability at melt temperature, to avoid degradation. Then, screw, nozzle, back flow valve, adaptor, should be designed to provide efficient melting of crystalline material and delivery of molten polymer to the mould.

Two rough methods to evaluate the presence of unmelt and of degraded material will be presented at the end of this chapter.

Thermal stability during processing

As presented in the previous chapter, one difference between amorphous and crystalline material is the “melting” behaviour. The amorphous polymer starts softening just after T_g and presents a continuous change in viscosity. This gives a very large temperature range to operate (but a large variation of viscosity with temperature). In contrast, the crystalline polymer stays solid up to the melting point and suddenly melts to the liquid phase at high temperature. This limits the processing range of temperature between unmelt and thermal degradation (specifically for DELTRIN® 190° C to 250° C).

The second factor is the **time** the material stays at that temperature. For all polymers, the molecules can withstand a certain time at a certain temperature before degradation can start. Obviously this acceptable time limit becomes shorter when the temperature is higher. The typical behaviour of DELTRIN® is presented

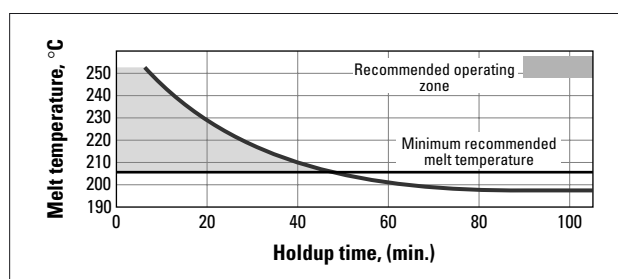

Fig. 3.01 Effect of temperature on Hold-up Time of DELTRIN®

in Fig. 3.01. Degradation of DELTRIN® will result in generation of gases which cause bubbles in the melt, splays on parts, mould deposit, yellow and brown marks on the parts.

The average residence time (or Hold Up Time, HUT) in the injection unit is linked to the amount of polymer in the cylinder, the shot weight and the cycle time and can be calculated with the following equation:

$$\text{Average HUT} = \frac{\text{weight of resin in cylinder}}{\text{shot weight}} \times \text{cycle time}$$

A quick approximation can be done by

$$\text{Average HUT} = \frac{\text{maximum screw stroke} \times 2}{\text{current screw stroke}^*} \times \text{cycle time}$$

* Effective screw stroke = distance the screw travels during rotation only

With a screw stroke of 1 diameter (a small shot) and a cycle time of 1 minute (a very long one), the average HUT is equal to 8 minutes. According to the degradation curve Fig. 3.01, DELTRIN® should be stable enough for injection-moulding with this hold-up time at a melt temperature of 240° C. Some customers have experienced moulding DELTRIN® successfully at that temperature.

At the recommended melt temperature of 215° C, the maximum HUT is over 30 minutes and DELTRIN® (standard grades) is thermally stable even under these extreme conditions.

There are 3 main potential causes of degradation:

- **Material trapped in Hold-up spots.** In the injection unit, trapped molten material will stay for very long times in any dead spots and will start to degrade. So all the injection unit (screw, back flow valve, adaptor, nozzle and hot runners) should be designed to avoid Hold-up spots (see following recommended design).
- **Material sticking to “hot” steel.** Due to the high viscosity of polymers, the speed next to the steel of the injection unit (screw, back flow valve, adaptor, nozzle and hot runner) is almost zero and the residence time is almost infinite (all moulders know how long it takes to change colors in an injection unit). Whereas inside the barrel the molten polymer is cleaned by the screw and the valve, inside all other areas the material will stick to the walls. To withstand a very long residence time, the steel in contact should be controlled at a temperature lower than 190° C (see Fig. 3.01).

- **Chemical degradation.** Contamination (e.g. PVC, flame retardant resins, acid generating resins), incompatible colouring systems (acid or basic pigments), contact with copper (pure, alloys, grease) will accelerate the thermal degradation of molten DELRIN® in the injection unit.

Note that mould components in copper or copper alloys (such as copper-beryllium) do not cause any degradation and have been used for years without problems.

Screw Design

Screw design is a key parameter for productivity, because for crystalline materials the screw rotation time is an inherent part of the cycle time.

As mentioned above, it should take in consideration the specific melting behaviour of the crystalline material, i.e. solid up to the melting point, high demand of heat during melting and low viscosity of the molten material.

Although “general-purpose” screws are widely used for moulding DELRIN®, optimum productivity will require a specific design. Exceeding the output capability of an inadequately designed screw will cause wide temperature variations and unmelted particles (sometimes unmelt and degraded material have been observed at the same time). The result is loss of toughness, variability in shrinkage and dimensions, warping, surface defects, plugged gates (leading to short shots) or other moulding problems.

Due to the specifics of the melting process of a crystalline polymer, a screw designed for DELRIN® will have shallow flight depths in the metering section and a slightly higher compression than a general-purpose screw. Specific suggestions are given for various screw diameters and composition of DELRIN® acetal resin in table 3.01. Compression ratio is the ratio of volume of one turn in the feed section to that in the metering section (can be approximated to the ratio of the depth of the two zones).

The length of the screw will also affect the melt quality (an insulating material needs some time to get the thermal energy transferred even if the shear contributes to the heating process).

The preferred length is about 20 times the screw diameter or 20 turns when the pitch and diameter are equal. The screw should be divided as follows: 30-40% (6-8 turns) feed section, 45-35% (7-9 turns) transition and 25% (5 turns) metering section. Screws with 20 turns are commonly divided into 7 turns feed, 8 turns transition and 5 turns metering. In screws less than 16 diameters long, it may be necessary to reduce

the pitch to get up to 20 turns. Definitely, the feed section should never be less than 6 turns.

The relatively high compression ratio screws suggested for DELRIN® are designed to increase the heat input by mechanical working of the resin. Because the energy for this increase comes from the screw motor, additional horsepower must be available if an increase in melting capability is to be realized.

Table 3.01 Screw design for DELRIN® acetal resins

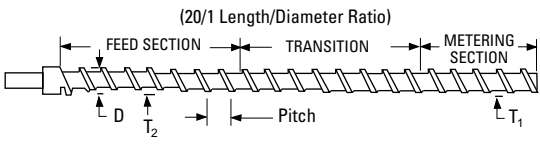

DELRIN® 500, 900, 500T (including the DELRIN® P grades)		
Nominal diam. mm	Depth of feed section (T ₂) mm	Depth of metering section (T ₁) mm
30	5,4	2,0
45	6,8	2,4
60	8,1	2,8
90	10,8	3,5
120	13,5	4,2

DELRIN® 100, 100ST		
Nominal diam. mm	Depth of feed section (T ₂) mm	Depth of metering section (T ₁) mm
30	5,2	2,6
45	6,5	2,8
60	7,5	3,0
90	8,7	3,6

Screw size

The ideal screw size is determined by the volume of the current shot. Optimum productivity will be achieved when the shot size requires a screw travel during plasticisation equal to or lower than 50% of the capacity of the injection unit. Otherwise, screw rotation speed will have to be decreased at the end of the travel to guarantee an homogeneous melt, leading to a loss in productivity. Practically, optimum productivity is achieved with a screw travel of between 1 and 2 diameters of the screw.

Thermal settings of the injection unit will be dependent on the residence time (HUT) and hence dependent on the cycle time. Rules will be presented in chapter 5.

Screw design for the use of colour concentrate

A flow analysis shows that the major part of the flow in the screw is laminar, then divided in the back flow valve (due to the changes in flow direction), and still

laminar in the adaptor, nozzle, sprue, etc. To get optimum melt quality, to disperse pigments and colour concentrates, it is strongly recommended to add a mixing head. The purpose of a properly designed mixing head is not to mix material by turbulence (turbulent flow is impossible with highly viscous molten polymer), but by forced changes in flow direction. The design of such a mixing device can be obtained on request from your DuPont representative.

Cylinder temperature control

This is determined by the machine manufacturer, but two comments should be made.

- The temperature control should provide at least three independent zones, with thermocouples placed near the centre of each zone. Burn-out of one or more heater bands within a zone may not be readily apparent from the temperature controllers, so some moulders have used ammeters in each zone to detect heater band malfunctions.
- Usually for DELRIN® there is no need to cool the feed throat, but in case such a need exists, the water flow should be kept to a minimum. Overcooling the feed throat has been observed as a major reason for contamination by black specks. These are generated in the barrel, between the first and second heating zones, with the following mechanism (see Fig. 3.02). The thermocouple TC1 is influenced by the low temperature due to excessive cooling, and the system will respond by switching ON the heating bands HB1 and HB2. This causes no problem with HB1, but results in overheating and degradation in the area under HB2. To reduce the risk of formation of black specks, the following recommendations should be observed: a) the feed throat cooling should be limited to a minimum temperature of 80-90°C; b) the heater band HB2 should be controlled by TC2, or TC1 should be placed in the middle of HB2, or HB2 should have half the power density of HB1.

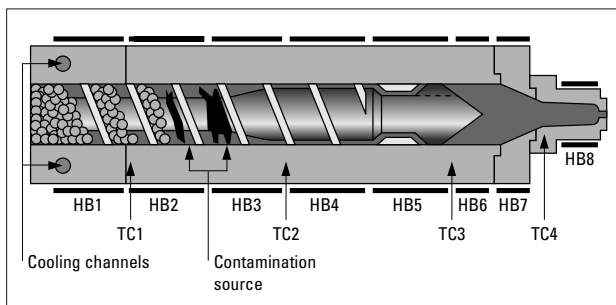

Fig. 3.02 **The risk of black specs contamination that could arise from the presence of a cooling system of the feed throat (source: CAMDO)**

Cylinder adaptor

The adaptor shown in the Fig 3.03 is designed to avoid holdup areas and flow restrictions, the two main causes of degradation and problems linked to this area. Note that the concept is the same for screwed adaptors as represented in Fig. 3.03 (used for small screws $\leq \varnothing 40$ mm) and for bolted adaptors (used for larger screws). The adaptors has short cylindrical sections (A and B) where it joins both the nozzle and the cylinder to maintain accurate matching of these diameters, even if it becomes necessary to reface the mating surfaces.

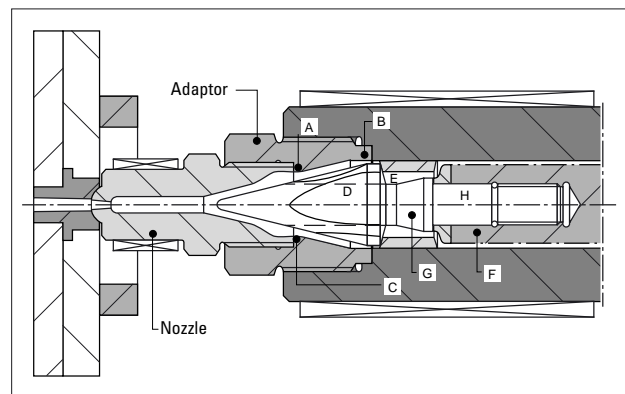

Fig. 3.03 **Design of adaptor and non-return valve**

The mating surfaces (C) should be narrow enough to develop a good seal when the nozzle or adaptor is tightened and yet wide enough to avoid deformation. In addition to its mechanical function of reducing the diameter, the adaptor acts to isolate the nozzle thermally from the front of the cylinder for better control of nozzle temperature. A separate adaptor, made of softer steel than the one used for the cylinder, is easier and less expensive to repair and change than a cylinder. It also protects the cylinder from damage due to frequent changing of the nozzle. With the bolted adaptor, special care should be taken during assembly to ensure parallelism (don't overtighten screws from one side only).

Non-return valve (Back Flow Valve – BFV)

The non-return valve or check ring shown in Fig. 3.03 prevents melt from flowing backward during injection. This unit is frequently not properly designed to eliminate holdup of resin and flow restrictions. Malfunctioning that allows resin backflow is also a common experience and is caused by poor design or maintenance. A leaking non-return valve will add to screw retraction time, which can increase cycle, and it will also cause poor control of packing and dimensional tolerances.

The non-return valve must meet the following requirements:

- No holdup spots.
- No flow restrictions.
- Good seal.
- Control of wear.

These requirements are provided for in the non-return valve shown in Fig. 3.03.

The slots or flutes (D) in the screw tip are generously proportioned, and the space (E) between the check ring and tip is sufficient for resin flow.

The seating of the fixed ring is cylindrical where it joins both the end of the screw (F) and the screw tip (G) to permit accurate matching of these diameters and avoid holdup.

The screw tip thread has a cylindrical section (H) ahead of the threads that fits closely in a matching counterbore for support and alignment of the screw tip and seat ring.

The screw tip and check ring seat should be harder (about Rc 52) than the floating ring (Rc 44), because it is less expensive to replace the floating ring when wear occurs.

Corrosion resistant steel is suggested for the tip. Good matching of cylindrical diameters is essential to avoid holdup spots.

Nozzle

As with other semi-crystalline polymers, DELRIN® may drool from the nozzle between shots if the nozzle is too hot, or it may freeze if too much heat is lost to the sprue bushing.

The nozzle design shown in Fig. 3.04 can solve these problems. The following should be considered:

1. The heater band (A) should extend as close to the nozzle tip as possible and cover as much of the exposed surface as practical. This counteracts any heat loss, especially heat loss to the sprue bushing.
2. The thermocouple location is important. An appropriate location (B) is shown in the same picture.
3. Adequate temperature uniformity is required so that local overheating or premature freezing is avoided.
4. To prevent polymer degradation the steel temperature should not exceed 190°C.
5. The nozzle heater should have its own independent temperature controller.

Screw decompression or “suck back” is frequently used to make control of drool easier with these open nozzles. This feature is available in most machines.

When not available, a design such as the one illustrated in Fig. 3.05 should be used.

Although shutoff nozzles have occasionally been used successfully with DELRIN®, they tend to cause holdup of resin that results in brown streaks or gassing, especially after some wear has occurred in the moving parts of the nozzle. These nozzles are not generally recommended for DELRIN® on safety grounds alone.

Note: With a long nozzle, the thermocouple well B should be positioned in the middle of the nozzle and not at the back of the nozzle.

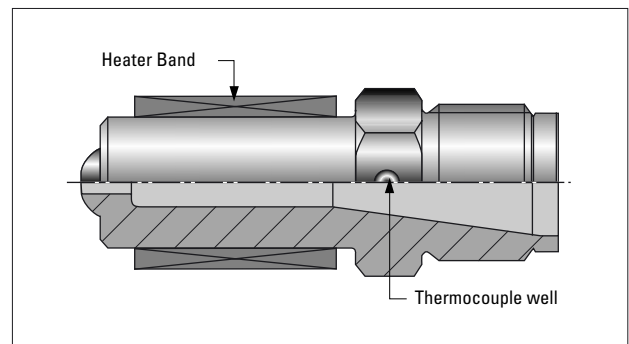

Fig. 3.04 Reverse taper nozzle

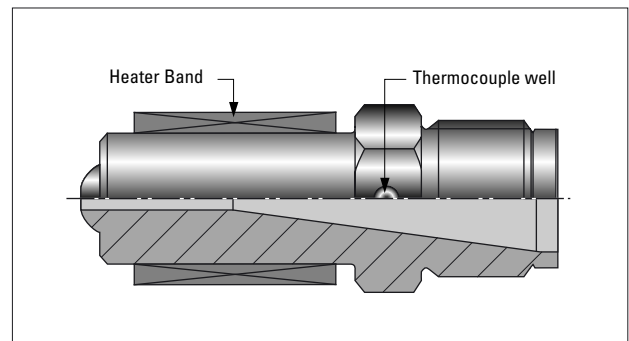

Fig. 3.05 Straight bore nozzle, only for machines without screw decompression

Evaluation of melt quality

Below are presented two “quick and easy” tests to evaluate the melt quality delivered by the injection unit. Although the result is linked with the temperature setting of the injection unit, it is also highly dependent on the design of the injection unit.

Foaming test

The foaming test is recommended to determine the quality of the resin after melting in the injection unit i.e. the quality of the resin AND the quality of the injection unit.

Procedure:

1. When the machine is running in cycle, stop the machine after screw retraction for 3 minutes for coloured DELRIN® (10 min for NC material).
2. Purge at low speed (to avoid hot splashes) into a cup and observe the molten material for 1 or 2 minutes. Then put the molten material in a bucket of water.
3. Then recharge the screw and wait 2 more minutes (10 more minutes for NC material).
4. Repeat operation 2.

An unstable melt will grow (foam) during the observation and float in the bucket. A stable melt will stay shiny with a tendency to shrink during the observation, and will sink in the bucket.

Foaming resin will quickly cause mould deposit and will accelerate screw deposit, which may lead to black speck contamination.

This technique is useful to evaluate non-DuPont colour systems (colour masterbatches, liquid colouring).

The foaming test can also be used to detect inadequate quality of the injection unit (e.g. problems of throat cooling and consequent overheating, excessive nozzle temperature, hold-up spots, etc).

Unmelt test

The unmelt test is recommended to evaluate melt homogeneity:

- When the press is running on cycle, stop at the end of a cycle and purge one shot;
- charge the screw immediately with the shot volume used and purge again;
- repeat the operation until detection of lumps/irregularities in the purge coming out of the nozzle.

If such lumps/irregularities appear after less than 3 purges, the risk of unmelt is very high and should be dealt with by increasing cylinder temperature, by lowering screw RPM and by increasing back pressure. If such changes lengthen the cycle time too much, a more appropriate screw design should be used (see table 3.01).

If lumps/irregularities appear after 3 purges but before 6, the situation is acceptable, but there is not much safety margin. If they appear after 6 purges, there is a very low risk of unmelt.

4. Moulds

DELTRIN® acetal resins have been used in many types of moulds, and moulders have a wealth of knowledge concerning mould design for DELTRIN®. Moulds for DELTRIN® are basically the same as moulds for other thermoplastics. The parts of a typical mould are identified in Fig. 4.01.

This section will focus on the elements of mould design that deserve special consideration for processing DELTRIN® and can lead to higher productivity and lower cost for the moulder. These topics are:

- Ability to fill
- Undercuts
- Gates
- Runnerless moulds
- Runners
- Mould maintenance
- Vents

Mould shrinkage and other aspects of mould sizing are discussed in Chapter 6: "Dimensional Considerations."

Ability to fill

Melt viscosity largely governs the ability of a resin to fill a mould. DELTRIN® acetal resins range in melt viscosity from DELTRIN® 900, the lowest in viscosity or most fluid, to DELTRIN® 100, the highest. The viscosity of DELTRIN® does not decrease rapidly as melt temperature increases, in contrast to amorphous thermoplastic resins, such as acrylic resin. Increasing melt temperature will not greatly improve the ability of DELTRIN® to fill a thin section.

In addition to the properties of the resin, the moulding conditions and cavity thickness determine the distance of flow. Fig. 4.02 shows the maximum flow distances that can be expected at two cavity thicknesses for DELTRIN® acetal resins as a function of injection fill pressure. These comparisons were made in an open-ended snake flow mould with no gate restriction. Obstructions in the flow path, such as sudden changes in flow direction or core pins, can significantly reduce the flow distance.

Fig. 4.01 Exploded view of mould

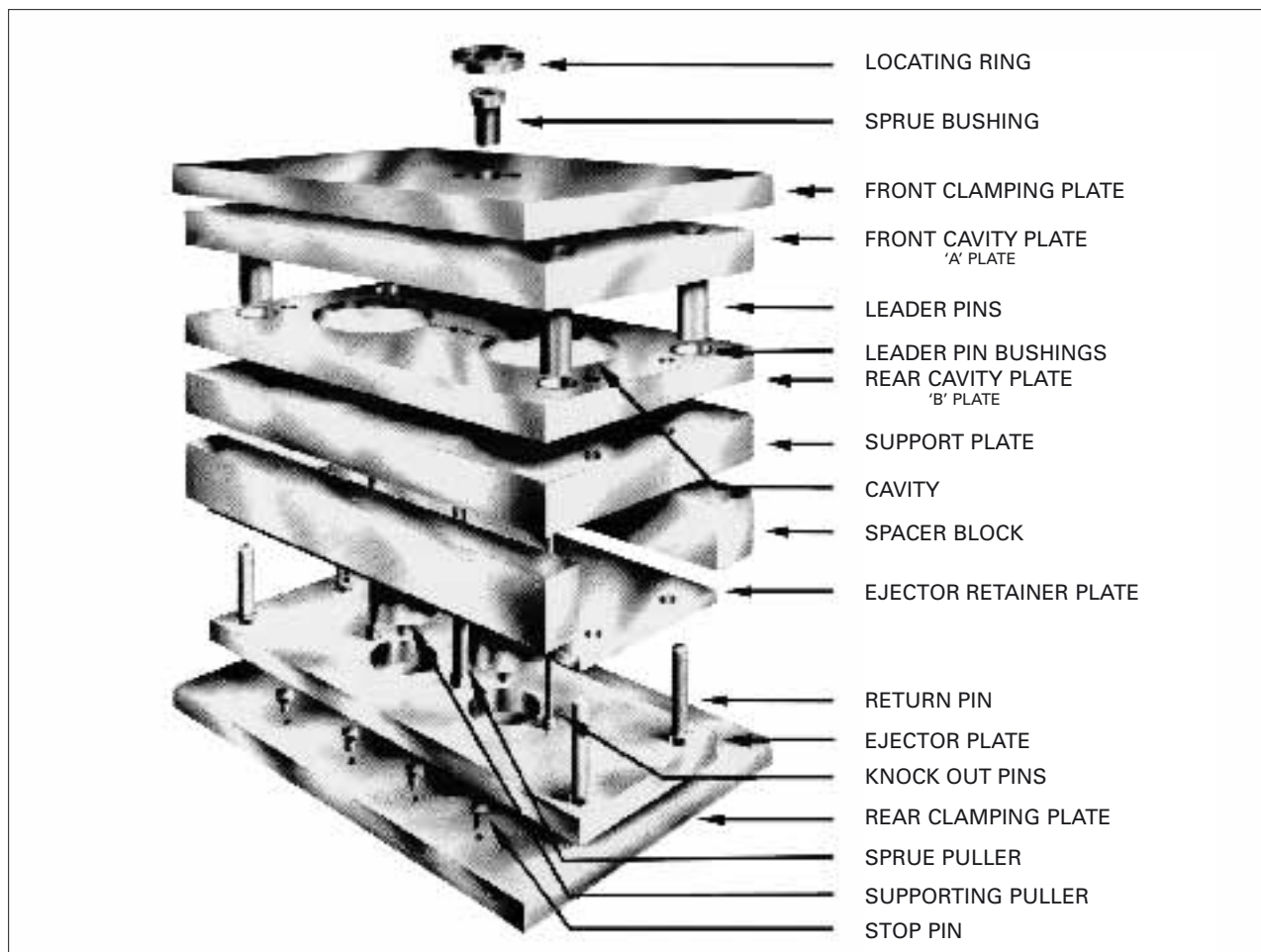

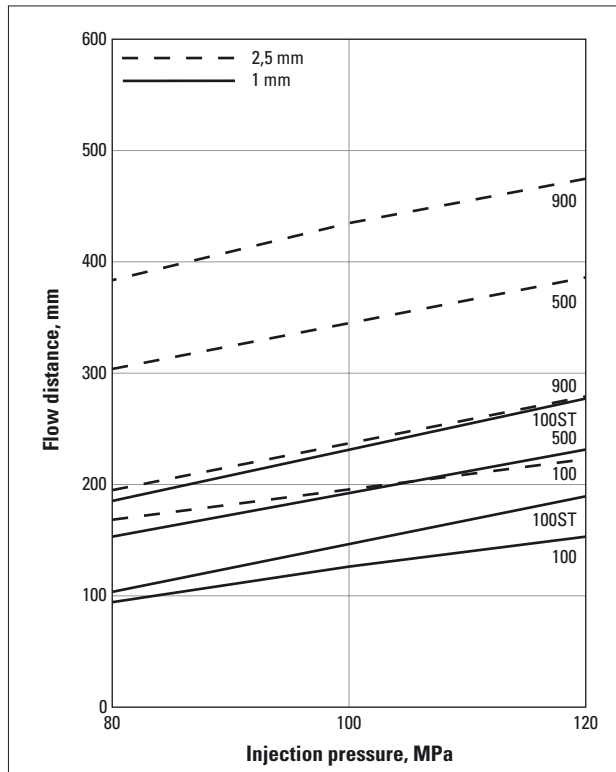

Fig. 4.02 Maximum flow distance of DELRIN® acetal resins

Gates

The gates of a mould play a major role in the success or failure of a moulding job. The location, design, and size of a gate are key factors to allow optimum packing. Obviously, the design will be different than the one used for moulding amorphous material. In that case the flow should stop as soon as possible after filling the cavity to avoid overpacking (flow in) and sink marks at gate (flow back). With crystalline material, the location, design and size of the gate should be such that it will allow a continuous flow during **all** the packing phase (Hold pressure time – see Chapter 5).

Gate location

As a key rule, when a part is not uniform in wall thickness, the gate must be located in the thickest section. The respect of this basic principle plays an essential role in obtaining optimum packing and consequently the best mechanical properties, dimensional stability and surface aspect. Of course every bottleneck (reduced section along the flow of the melt) should be avoided between the gate and all areas of the part.

An area where impact or bending will occur should not be chosen as the gate location, because the gate area may have residual stress and be weakened since it works as a notch. Similarly, the gate should not cause a weld line to occur in a critical area. The gate should be positioned so that the air will be swept toward a parting line or ejector pin – where conventional vents can be located. For example, a closed-

end tube such as a pen cap should be gated at the center of the closed end, so air will be vented at the parting line. An edge gate will cause air trapping at the opposite side near the closed end. When weld lines are unavoidable, for example around cores, an escape for gases must be provided to avoid serious weakness and visual flaws. Specific recommendations for venting are given later in this section.

Another consideration in choosing a gate location for DELRIN® is surface appearance. Gate smear or blush, as well as jetting, are minimized by locating the gate so that the melt entering the cavity impinges against a wall or core pin.

A central gate location is often necessary to control roundness of gears and other critical circular parts. Multiple gates, usually two to four, are commonly used when there is a central hole to avoid a difficult-to-remove diaphragm gate.

Gate design

As mentioned above, for crystalline materials like DELRIN® the thickness of the gate or its diameter (for a pin-point gate or tunnel gate) determines the freeze-off time, and therefore also determines whether it is possible to pack the part (to compensate the volume reduction due to crystallisation) and maintain the pressure during solidification. The gate should remain open until the part density is maximum for a specific material. The thickness (or diameter) of the gate should amount to 50-60% of the wall thickness at the gate. The width of the gate should always be equal or greater than the gate thickness. The length of the gate should be as short as possible and never exceed 0,8 mm. The gate area of the part should not be subjected to bending stresses during actual service. Impact stresses are particularly liable to cause failure in the gate area.

The most common types of gates are summarised in Fig. 4.03.

- DIAPHRAGM GATE: Circular gate used to fill a single symmetrical cavity. The advantages are a reduction of weld line formation and improvement of filling rates. However the part has to be machined to remove the gate.
- DIRECT GATE: The sprue feeds directly into the mould cavity without runners. This design may often lead to surface defects coming from the nozzle (cold slug, cold skin, entrapped air...).
- EDGE GATE: Usual type of gate with two plate moulds. It is not self degating.
- FAN GATE: This gate is used to enlarge the flow front. Usually it leads to a reduction of stress concentrations in the gate area. Less warpage of parts can usually be expected by the use of this gate type.

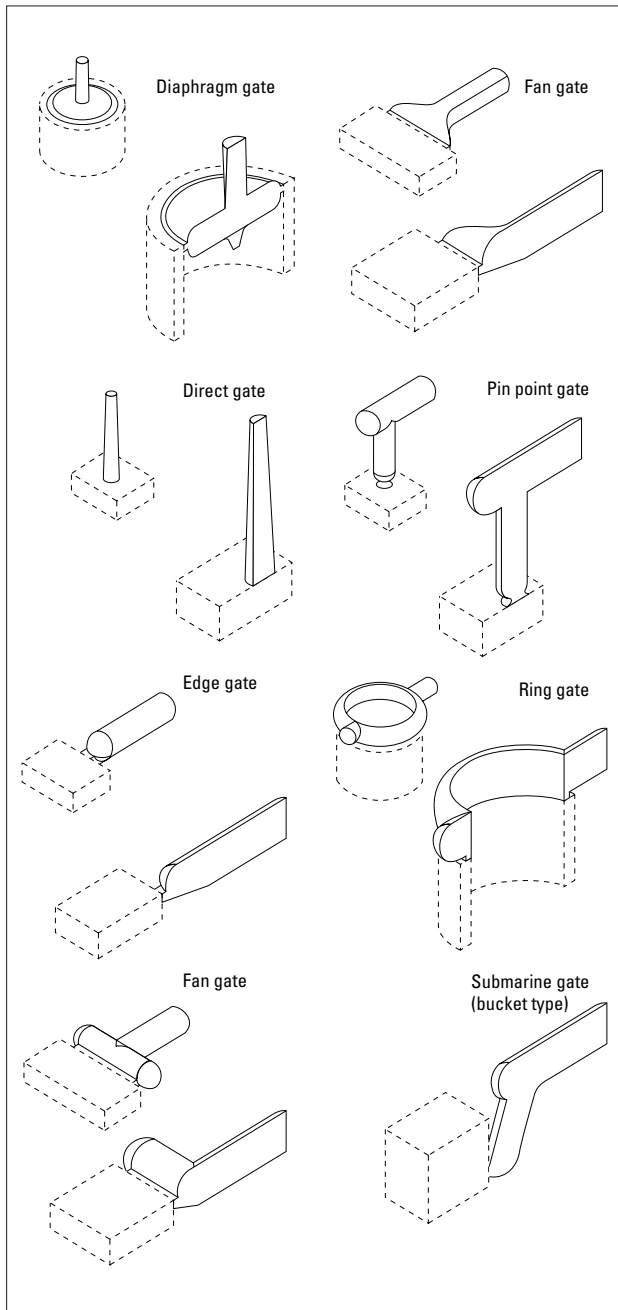

Fig. 4.03 Schematic view of the most common types of gates

- PIN POINT GATE: This gate is used with three plate moulds. It is self degating.
- RING GATE: See DIAPHRAGM GATE.
- SPRUE GATE: See DIRECT GATE.
- SUBMARINE GATE: A type of edge gate where the opening from the runner into the mould is not located on the mould parting line. It is used to separate the gate from the part with a two plate mould (self-degating).
- TUNNEL GATE: See SUBMARINE GATE.

Details of a typical edge gate suitable for DELRIN® are shown in Fig. 4.04.

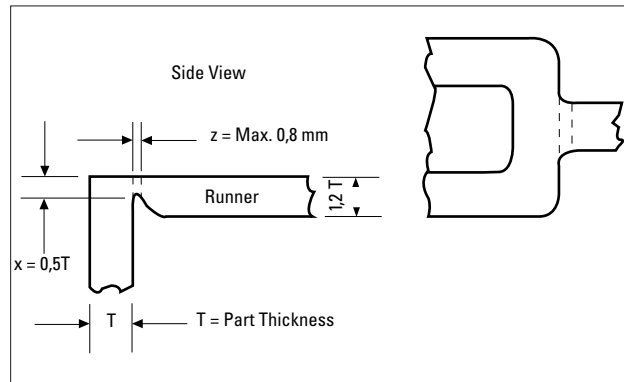

Fig. 4.04 Details of a typical edge gate suitable for DELRIN®

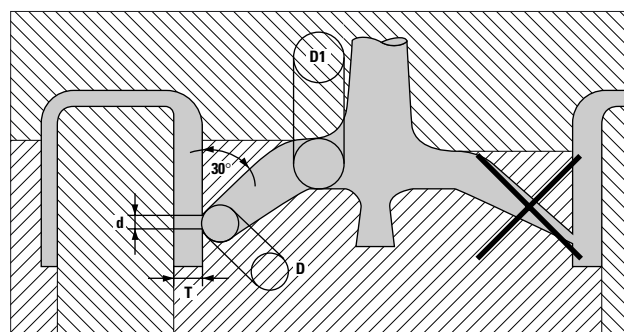

Fig. 4.05 Details of a submarine gate (tunnel gate) adequate for DELRIN® (left side). The one on the right is not adequate for crystalline polymers and would give problems with DELRIN®

Fig. 4.05 shows details of a submarine gate adequate for DELRIN® (left), compared to a similar type of gate not recommended for crystalline materials (right).

Design criteria:

- always gate in thickest area of the part;
- diameter of the gate “d” must be at least half the part thickness. The length must be shorter than 0,8 mm to prevent premature gate freezing during packing;
- the inscribed diameter “D” of the tunnel next to the gate must be at least $1,2 \times$ the part thickness “T”.

The gate shown on the right of Fig. 4.05 side is not recommended for crystalline materials like DELRIN®, because such conical gate sections crystallise before the end of complete part pack out. This results in low mechanical performance and uncontrolled shrinkage.

Fig. 4.06 shows details of a “three plate” gate design adequate for DELRIN® (left), compared to a similar type of gate not recommended for crystalline materials. The design criteria illustrated above are also applicable to this kind of gate.

Note: Restrictions around the sprue puller will lead to incomplete part pack out. So, the diameter “D1” in Fig. 4.06 should be at least equal to diameter “D”.

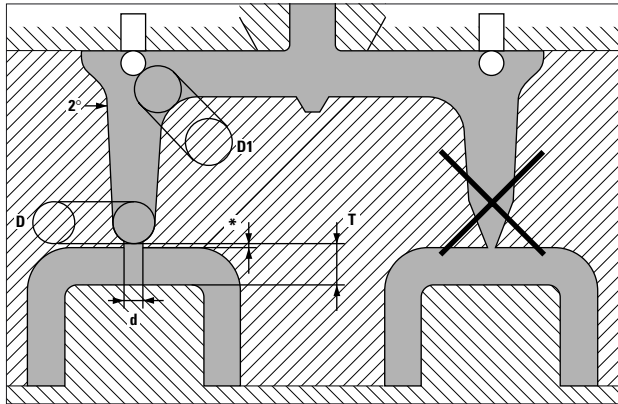

Fig. 4.06 Details of a "three plate" gate design adequate for DELRIN® (left side). The one on the right is not adequate for crystalline polymers and would give problems with DELRIN®.

* Gate length should be <math>< 0,8\text{ mm}</math>

Runner system

Guidelines

Key guidelines to follow when designing a runner system include:

- runners should stay open until all cavities are properly filled and packed;
- runners should be large enough for adequate flow, minimum pressure loss and no overheating;
- runner size and length should be kept to the minimum consistent with previous guidelines.

Each of these factors can affect quality and cost of moulded parts. Factor (a) should be regarded as the most critical.

The cross section of the runners is most often trapezoidal, which represents an optimum practical compromise with respect to the full round section. The effective cross section of the runner is in this case the diameter of the full circle that can be inscribed in it.

For parts of DELRIN® to have the best physical properties, the runners next to the gate must have at least an inscribed diameter of 1,2 times the part thickness "T".

When the mouldings are very thin, however, this runner cannot be less than about 1,5 mm in thickness. The runner thickness is usually increased at each of the first one or two turns from the cavity, as shown in the example of Fig. 4.07.

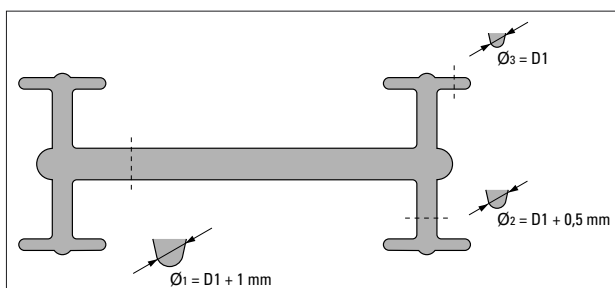

Fig. 4.07 Correct runner thickness for an eight cavity mould

Single cavity mould

The simplest runner configuration for a single cavity mould could be direct gating (see Fig. 4.08, left). In this case, however, it would be necessary to have a "cold slug catcher" directly on the part, with associated surface problems and lower mechanical properties in that area. The preferred solution is then to "break the flow" as indicated in Fig. 4.08, right.

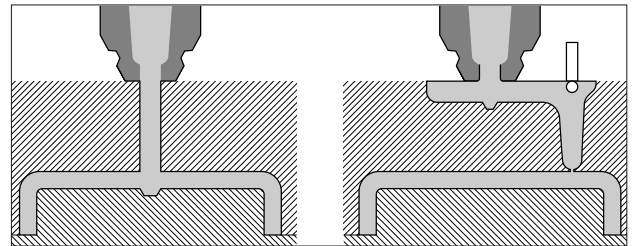

Fig. 4.08 Direct gating (left) and indirect gating to break the flow (right), in a one-cavity mould

Runner layout

A perfectly balanced layout (with equal flow distance from the sprue to each cavity) is best achieved if the number of cavities is equal to a power of 2 (2, 4, 8, 16, 32, 64, 128...). See an example of a 16-cavity mould in Fig. 4.09 with balanced (left) and unbalanced runner systems. A perfectly balanced layout may be impractical and expensive.

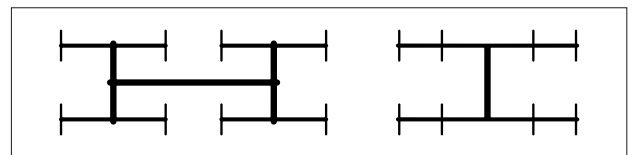

Fig. 4.09 Balanced (left) and unbalanced (right) runner systems in a 16-cavity mould

When an unbalanced runner system is selected, the layout shown in Fig. 4.10 (left) could present more risks of quality problems. The flow tends to stop at each of the early gates due to the restriction and the material starts to crystallize. Then, as the runner continues to be filled, the pressure rises and the cold slugs which started to be built up, are pushed into the cavity.

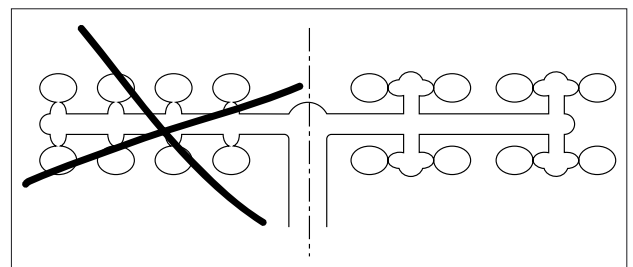

Fig. 4.10 Examples of unbalanced 16-cavity mould. The solution on the right is provided with overflow wells to trap "cold slugs"

To reduce such risk, the solution shown in Fig. 4.10 (right) is recommended. In such configuration, the cold slugs tend to be trapped into each overflow well.

In case of multi-cavity moulds (≥ 16 cavities), the so-called "spiral effect" could take place in the "internal" cavities of the layout (see for instance Fig. 4.11), due to over-heating of the melt in runners, caused by localised shear. To minimize negative effect like splays or mould deposit, shear should be reduced by using appropriate runner dimensions.

For multi-cavity moulds for small thickness parts (≤ 1 mm), the design of runners should be checked by running a detailed flow analysis study.

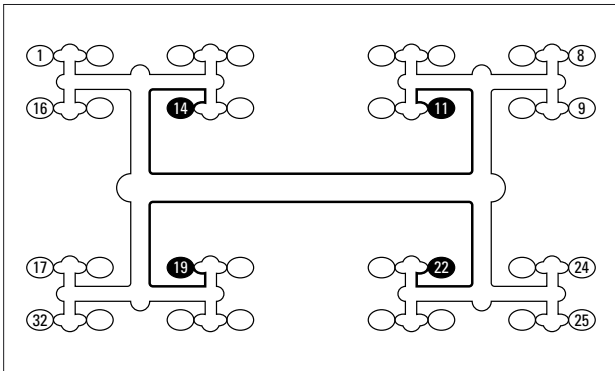

Fig. 4.11 Example of "spiral effect" in a 32-cavity mould. Cavities 11, 14, 19, 22 will be filled first and may show splays and mould deposits

Nozzle and sprue

Nozzle and sprue diameters are directly linked with the dimensions of the part and of the runners. The designer should first decide if the sprue is needed or not. If yes, a design like the one shown in Fig. 4.12 could be selected, one that in many cases has proved to be the most effective with crystalline materials like DELRIN®. Due to its parallel cylindrical shape it is easy to machine and polish, allows large nozzle diameters, and it is easy to eject due to high shrinkage. Guidelines for the dimension are:

- a sprue diameter $\varnothing 1$ at least equal to the inscribed diameter of the main runner;
- a nozzle diameter "DN1" equal to $\varnothing 1$ minus 1 mm.

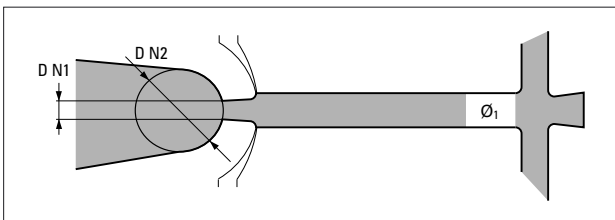

Fig. 4.12 Sprue and nozzle design often used with DELRIN®. The dimensions are linked with the dimensions of the part and of the runners

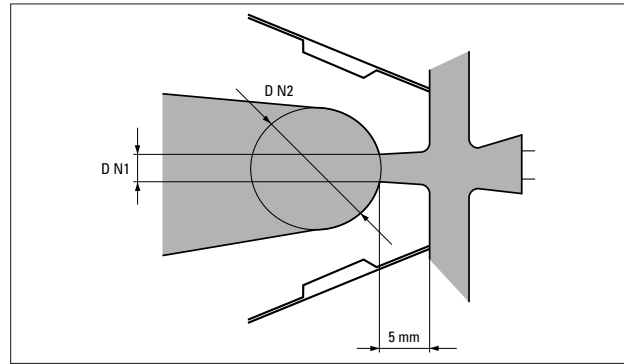

Fig. 4.13 Example of a design of a nozzle without sprue used with 2 plate moulds. Remember that for DELRIN® the nozzle temperature should not exceed 190° C

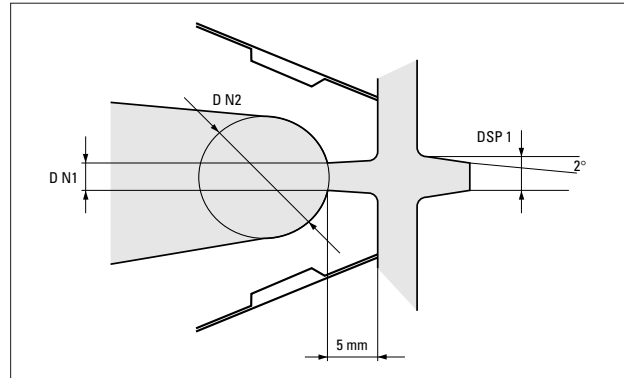

Fig. 4.14 Example of a design of a nozzle without sprue used with 3 plate moulds. Remember that for DELRIN® the nozzle temperature should not exceed 190° C

In case the designer selects a design without a sprue, a long nozzle may be required as shown in Fig. 4.13 for a 2 plate tool, and in Fig. 4.14 for a 3 plate tool. Again, the dimensions are linked to the dimensions of the part and of the runners (guideline: nozzle diameter "DN1" equals to the main runner inscribed diameter minus 1 mm).

A review of the key-recommendations related to the sprue and runner system follows. It can be used as a quick reference list to check their design.

1. Cylindrical parallel sprue preferred: see Fig. 4.12 and Fig. 4.15-1.
2. Sprue puller for 2 plate mould: see Fig. 4.15-2.
3. Cold slug well for 3-plate mould: see Fig. 4.15-3.
4. Perpendicular flow splits with cold slug wells at each split, see Fig. 4.15-4.
5. No flow restriction caused by sprue puller in 3 plate mould, see Fig. 4.15-5.
6. Runner dimensions:
 - for parts having thickness $> 1,5$ mm, follow general rules for crystalline polymers (Fig. 4.07);
 - for thinner parts and multi-cavity moulds, a flow analysis may be required to select dimensions that will avoid over-shearing.
7. Runners should be properly vented, see Fig. 4.15, 4.16 and Fig. 4.17.

8. Balanced runners recommended (see Fig. 4.11).
9. For thin parts and large number of cavities, unbalanced runners may be acceptable. However, parts should never be gated directly onto the main runner (see Fig. 4.10).

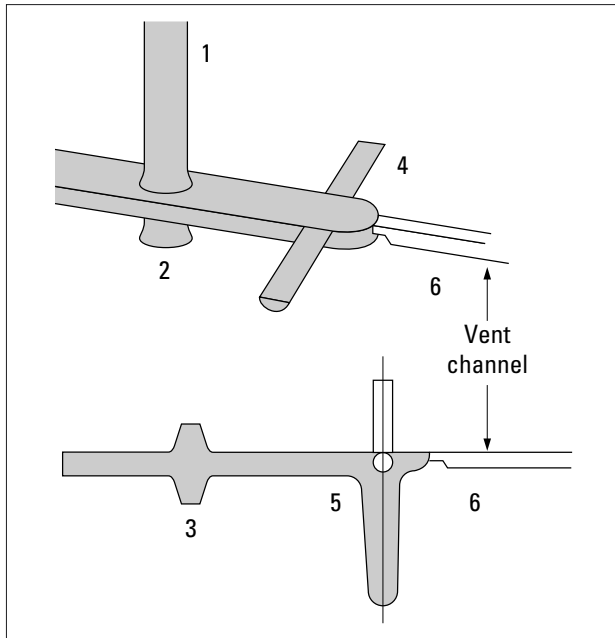

Fig. 4.15 Key rules for the design of the sprue and runners of a 2 plate mould (top) and of a 3 plate mould (bottom)

Hot runner mould for crystalline polymers

Preliminary comments

This section includes all hot runner, hot sprue bush, and runnerless moulds. The following is not intended to recommend any trademark or system but to present the behaviour and the needs of crystalline polymers in such tools.

The question that frequently arises is when to use hot runner moulds with crystalline polymers like DELRIN®. This is a highly controversial subject.

The choice depends on many factors, and particularly on the quality needed, i.e. mechanical performance, surface aspect, percentage of rejects.

Status

All such moulds give the obvious advantages of less material to plastify, no (or minimum) regrind and shorter cycles. On the other hand, hot runner moulds are more expensive and heavier; they need more maintenance and better-trained operators than conventional moulds. In addition, if they are not properly designed, the heat needed to run them could spread to all parts of the mould and can in fact cause the cycle time to increase.

One approach is to evaluate the expected increase of theoretical productivity versus conventional moulds. If such an increase is lower than 25%, it would be wise to stay with a 3 plate mould that will be cheaper to build, start and run.

The break-even of about 25% applies to full hot-runner systems; for other moulds (with hot sprue bushes, cold sub-runners) the break-even point is much lower.

Direct gating versus cold sub-runners for crystalline polymers

When designing a hot runner mould for crystalline polymers, it should be kept in mind that direct gating via hot runner is more difficult with crystalline polymers than with amorphous ones. The difference comes from the softening or melting behaviour of these two types of polymers.

An amorphous material exhibits a gradual softening behaviour above T_g from the solid state to the liquid state, allowing a wide processing window in terms of temperature and viscosity. In fact, as its temperature increases above T_g (see Fig. 4.16) an amorphous polymer (curve "A") lends itself first to thermoforming ("T"), then to blow moulding ("BM") and finally to injection moulding ("IM").

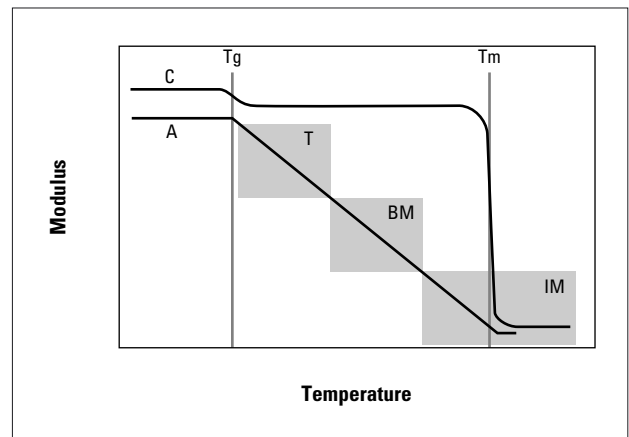

Fig. 4.16. Softening / melting behaviour of amorphous and crystalline polymers

On the contrary, the T_g has usually a limited or negligible effect on the structure of crystalline polymers, which are solid above T_g . At the temperature T_m , crystalline polymers melt sharply and become liquid (curve "C").

Such behaviour of a crystalline material may involve the risk of:

- Drooling around the gate with consequent problems of bad surface aspect and deformation.

- Plugging of the gates by solidified material, plugs which will be pushed into the cavities, with consequent problems of surface defects and lower mechanical performances. The best way to prevent such problems is to use COLD SUB-RUNNERS.

Thermal control of hot runner moulds

Thermal management and streamlining of the flow are very important for hot runner tools. It should be checked that a relatively low temperature setting ($\leq 190^\circ\text{C}$) gives an easy flow of the material with no hold-up spots.

The reason is that, due to the viscosity of the polymer, its flow is always laminar. This means that the material will remain against the steel wall of the hot runner, and residence time will be very long. For DELRIN[®], to avoid thermal degradation with prolonged times, the steel temperature should never exceed 190°C . If the hot runner system solidifies at that temperature, then it must be modified to improve thermal insulation and heat distribution to remove cold spots. Degradation can result in splays, odour, black specks and mould deposit.

Conclusions

With crystalline polymers such as DELRIN[®], we recommend the following:

- A minimum of 25% theoretical cost decrease should be expected before a hot runner is considered.
- Highly trained machine operators and mould maintenance toolmakers should be available.
- Use of cold sub-runners, never direct gating straight onto the part.
- Use of DELRIN[®] P grades.
- All temperatures in the hot runner system must not exceed 190°C .
- Avoid the use of hot runner moulds if surface defects are not acceptable and high part mechanical performance is required.
- Avoid the use of hot runners for toughened grades.

Vents

Venting a mould for DELRIN[®] is particularly important, and special attention should be given to this factor during both the design of the mould and its initial trial.

This attention is required because burning of parts caused by inadequate venting is not easily observed with DELRIN[®]. With other resins, poor venting results in a blackened and burned spot on the part. With DELRIN[®], however, there may be either no visible flaw or an inconspicuous whitish mark on the moulding.

Venting problems with DELRIN[®] acetal resins may be made more obvious by spraying the mould with a hydrocarbon or kerosene-based spray just before injection. If venting is poor, the hydrocarbon will cause a black spot where the air is trapped. This technique is particularly useful for detecting poor vents in multi-cavity moulds. A convenient source of hydrocarbon spray is a rust preventative spray.

Vents should be located at:

1. the end of any runner;
2. any flow junction where air is entrapped and a weld line results. The position of weld lines can be defined by short shots.

Only **no** venting together with excessive fast injection speed will cause corrosion of the tool at the weld lines with DELRIN[®] (diesel effect). Inadequate venting of moulds for DELRIN[®] may cause a gradual buildup of mould deposit where vents should be located and in mould crevices through which limited venting has taken place. These deposits consist of a white solid material formed from the traces of gas evolved during normal moulding. Good vents allow this gas to escape with the air from the cavities.

Poor venting may also reduce physical properties at weld lines.

Venting problems may be aggravated by high melt temperature, long holdup time, or holdup areas in the injection cylinder, which will generate more than normal amounts of gas. Fast injection fill speed will also aggravate these problems. Remedies for mould deposit problems are listed in the "Troubleshooting Guide."

Venting usually occurs through the parting line of a mould, and is provided by machining channels in the cavity plate and inserts.

In some cases, venting may be accomplished around an ejector pin. This vent will also be improved by grinding flats on the pin and relieving the vent after a short land. Pins that do not move with the ejection system tend to clog and no longer provide venting after a short time.

Venting the runner system is helpful in reducing the amount of air that must be vented through the cavities. Because flash is unimportant on the runner, these vents can be slightly deeper than cavity vents, for example, 0,06 mm.

The drawings in Fig. 4.17 show the recommended dimensions for vents in cavities for DELRIN[®].

Note: During mould maintenance, vent depth and/or hobbing should be carefully checked. Vents should be modified if the vent depth is less than 0,01-0,015 mm.

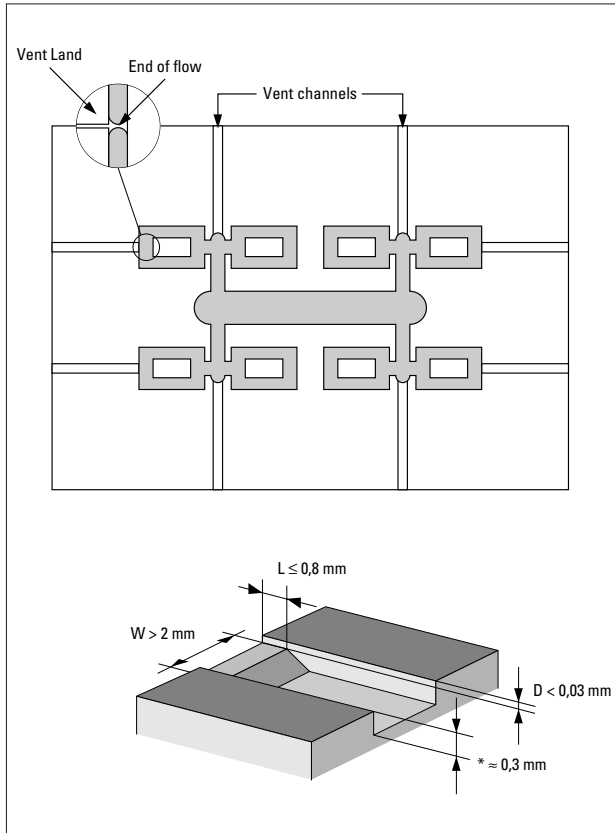

Fig. 4.17 Recommended venting of a part and of its runner system

- Generally, parts of DELRIN® acetal can be moulded with a maximum 5% undercut. Calculation of allowable undercut is illustrated in Fig. 4.18. The allowable undercut varies somewhat with both wall thickness and diameter.

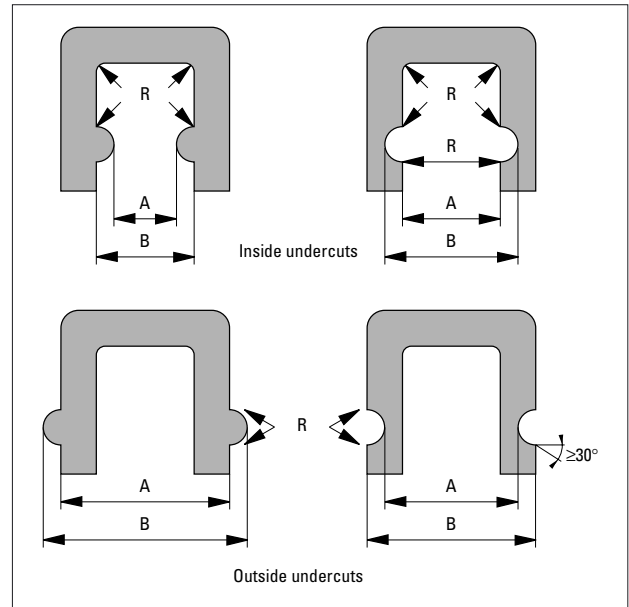

Fig. 4.18 Calculations for % undercut $(B - A) / B \leq 5\%$

Undercuts

General suggestions for stripping undercuts with DELRIN® acetal resins are:

- The undercut part must be free to stretch or compress, that is, the wall of the part opposite the undercut must clear the mould or core before ejection is attempted.
- The undercut should be rounded and well-filleted to permit easy slippage of the plastic part over the metal and to minimize stress concentration during the stripping action.
- Adequate contact area should be provided between the knockout and plastic part to prevent penetration of the moulded part or collapse of thin wall sections during the stripping action.
- The length of the moulding cycle and specifically the Hold (Pressure) Time (HPT) should be optimum to avoid excessive shrinkage with inside undercuts. Sufficient part rigidity must be developed without causing binding due to excessive shrinkage around pins forming an internal undercut. Ejection of parts with undercuts on the outside diameter will be aided by mould shrinkage.
- Higher mould temperature, which keeps the part hotter and more flexible when the mould opens, may aid ejection from an undercut.

Sharp corners

One of major causes of failure of plastic parts are internal sharp corners. A sharp corner in a part acts as a notch and initiates break at a very low energy. The diagram in Fig. 4.19 shows the effect of notch radius on impact resistance of test bars moulded in two grades of DELRIN®. Note that the notches have been moulded (simulation of real life and not machined as required by the standard Izod test).

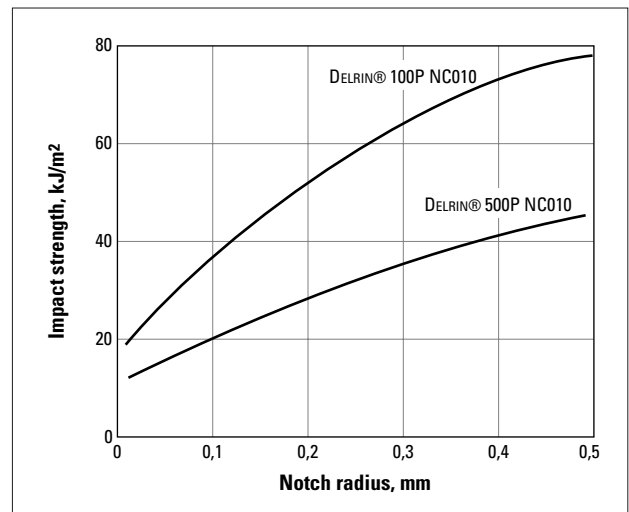

Fig. 4.19 Impact strength as a function of moulded notch radius

From this diagram it can be seen that an increase of an internal radius of curvature from 0,01 (almost a sharp corner) to 0,2 mm doubles the impact resistance.

Note also that sharp corners are not desirable in plastic parts because they are an important contributing factor to warpage.

Ribs design

Very often, ribbed parts will perform much better in term of cycle time, mechanical performances and warpage than very thick improperly packed parts. It is economically impossible to pack sections above 6-8 mm thickness during all the crystallization time (solidification: see Fig. 5.05 for Hold (pressure) Time vs part thickness). However an improper rib design could also cause defects such as sink marks.

Recommended rib dimensions are shown in Fig. 4.20. Note that the radius at the base of the rib should not be too small to preserve part toughness (see Fig. 4.19).

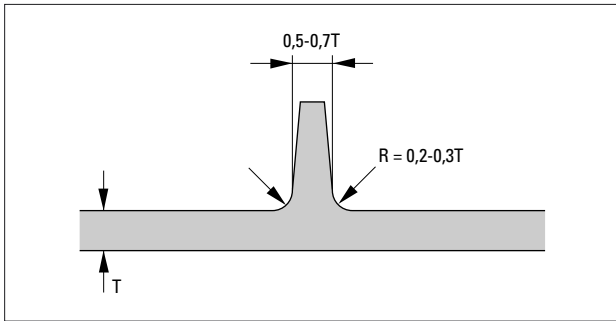

Fig. 4.20 Suggested rib dimensions versus wall thickness

Weld lines

Weld lines occur where two melt flows join together. Weld line position can be defined by short shots, or by flow simulations (if the mould does not exist yet). If the mould is provided with proper venting (see page 21), the weld line strength should be at least 80-90% of the nominal strength value of the resin.

To optimise weld-line strength, two parameters are important:

1. optimum Hold (Pressure) Time, to ensure the welding of the flow fronts under pressure (for the correct HPT see Chapter 5);
2. optimum filling rate, which will depend on part thickness (approximately 1 second per mm of part thickness).

Fig. 4.21 shows the weld line strength of a 4 mm thick test bar in DELRIN® 100 gated at both ends. Both tensile strength and toughness are seriously affected if filling time is not optimised.

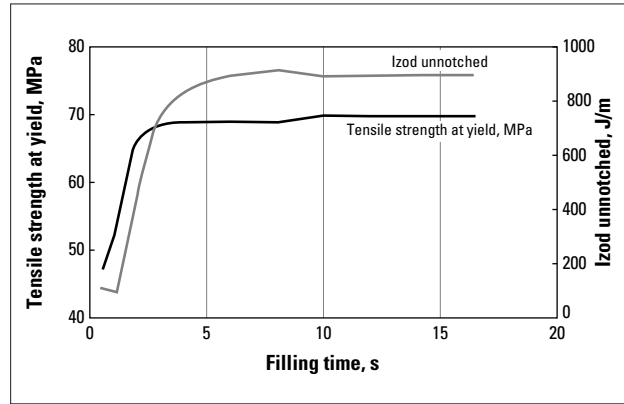

Fig. 4.21 Tensile strength (left scale) and unnotched Izod impact (right scale) of a DELRIN® 100 test bar, 4 mm thick, moulded at both ends with different Filling Times

Mould maintenance

As a general rule, moulds for processing DELRIN® require the same care as those for processing other thermoplastic materials. Wiping the mould and applying a rust-preventing solution is usually adequate after a production run.

Vent maintenance

Due to the critical nature of the vents, the vent dimensions should be checked during routine maintenance. Vent depth and/or hobbing (deformation of the parting line opposite the vent) should be carefully checked. Vents should be modified if the vent depth is less than 0,01 mm to 0,015 mm. Any hobbing that blocks the vents should be ground off.

Mould cleaning

Depending on the type of deposit the cleaning procedure is as follows:

• White deposit

White deposit is known as "P deposit", that is due to the accumulation of paraformaldehyde. This deposit can be removed with benzyl alcohol or isopropanol. Frequent cleaning of the tool with these solvents during moulding will prevent the accumulation of P deposit.

• Translucent or coloured deposit

This deposit is known as "S deposit". It is normally observed near the gate (in case of overshear of the material), on pins or near hot spots. The use of a less "shearing" gate (see gate design recommendations) or a more even mould temperature will stop or tremendously decrease the build up of this deposit. It can be removed with commercial alkaline chemical cleaners. Efficiency of the cleaning agent can be improved with an ultrasonic bath.

5. Moulding process

Injection moulding of DELRIN® acetal resin is similar to that of other thermoplastic resins. The engineering applications for which DELRIN® is used, however, frequently require tight specifications on strength, dimensions and surface condition, so that control of the moulding operation becomes more critical.

The information discussed in this section includes suggestions for:

- Start-up and shutdown procedures, handling precautions.
- Operating conditions for DELRIN®.
- Techniques for optimum productivity moulding.

Start-up and shutdown procedures

Start-up with resin change

The suggested start-up procedure with DELRIN® is designed to prevent overheating of the resin and contamination in the injection unit with material from previous runs.

To start up a machine which contains another resin, the injection unit must be purged with crystal polystyrene until the cylinder and other high temperature zones have been cleared. This can normally be done with cylinder temperatures in the range 210-250°C, if appropriate for the previous material. The nozzle is quite difficult to clean by purging, because the laminar flow in this area leads to a layer of polymer sticking to the metal (this is also true for hot runners). It is therefore recommended to switch off the nozzle heater, remove the nozzle, clean it to get rid all traces of previous polymer, and reassemble it. The cylinder temperatures should then be adjusted to about 215°C, and the nozzle temperature to 190°C. When both cylinder and nozzle have reached the expected temperatures, DELRIN® can be added to the hopper.

Safety point: Polystyrene is chemically compatible with DELRIN®, whereas even a trace of polyvinyl chloride (PVC) is not. Contamination of DELRIN® with such material can cause objectionable odour or even a violent blowback.

Start-up from a cylinder containing DELRIN®

After a safe shut-down procedure, the screw and the cylinder should be essentially empty. To restart, the nozzle and cylinder temperatures should be set at 190°C to preheat the cylinder and the resin it contains. When the cylinder has reached the set temperature, ensure that the nozzle is open and increase the cylinder settings to normal operating temperatures.

When all temperatures are in the operating range, the hopper can be filled and moulding can begin after a brief purge with DELRIN®.

Shutdown when a restart with DELRIN® is planned

Shut off the hopper feed and continue moulding until the cylinder is empty. For large machines (with a screw diameter above 40 mm) it is recommended to purge the cylinder with crystal polystyrene, move the screw fully forward, then switch off the heater bands. For small machines move the screw fully forward and switch off the heater bands.

Shutdown when a restart with another resin is planned

Shut off the hopper feed and continue moulding until the cylinder is empty. Purge with crystal polystyrene, leave the screw fully forward, then switch off the heater bands.

Temporary interruption

A moulding machine with DELRIN® in the cylinder at moulding temperatures should not be allowed to stay idle. The maximum recommended cylinder residence time, under normal moulding conditions, is 10 minutes for coloured material and 20 minutes for natural standard material. In excess of these times, resin decomposition may occur.

If, during the temporary interruption, the cylinder residence time reaches the above limits, close the hopper feed, empty the cylinder and leave the screw forward. The cylinder temperatures should be reduced to about 150°C (at these temperatures DELRIN® will be stable even for a weekend shutdown).

Action to follow when the nozzle heater band breaks down

Retract the injection unit, close the hopper and slide it out of the way. If the nozzle is still open, follow the normal shut-down procedures. If the nozzle is frozen, heat the nozzle with a gas torch to melt the frozen material inside the nozzle and then purge.

Operating conditions for DELRIN® – temperature settings

Introduction

The basic purpose of the injection unit is to deliver to the mould the necessary amount of a homogeneous melt (no unmelt and no degraded material). The rules of construction of the injection unit for moulding a crystalline material have been presented in Chapter 3, the rules for the settings are presented on the next page.

Note: Two rough but practical methods to evaluate the presence of unmelt and of degraded material were described at the end of Chapter 3 and can be used here as well.

DELTRIN® acetal resin is a crystalline polymer with a melting point of 177°C. For most grades of DELTRIN® the preferred melt temperature range is 215°C ± 5°C*, as measured with a needle pyrometer in the melt. The calories needed to heat and melt DELTRIN® will be provided by shear (from screw rotation) and the balance by conduction in the heated cylinder (slow heat transfer due to the insulating character of polymers).

Cylinder temperature

The main parameter influencing the temperature profile of the cylinder is the residence time (or Hold-Up Time – HUT) of the polymer in the plastification unit (see page 9 to calculate HUT).

With a short HUT (<3 minutes, short cycle time, high melt output), higher than normal cylinder settings may be required. With a long HUT (>5 minutes, long cycle time, low melt output), lower settings, especially in the rear zone, may be used. Since generalisation of cylinder temperature settings is difficult, it is often wise to begin with a level profile and adjust as needed. The diagram shown in Figure 5.01 can be used as a guideline for initial temperature settings.

* The preferred melt temperature for DELTRIN® 100ST and DELTRIN® 500T is about 10°C lower.

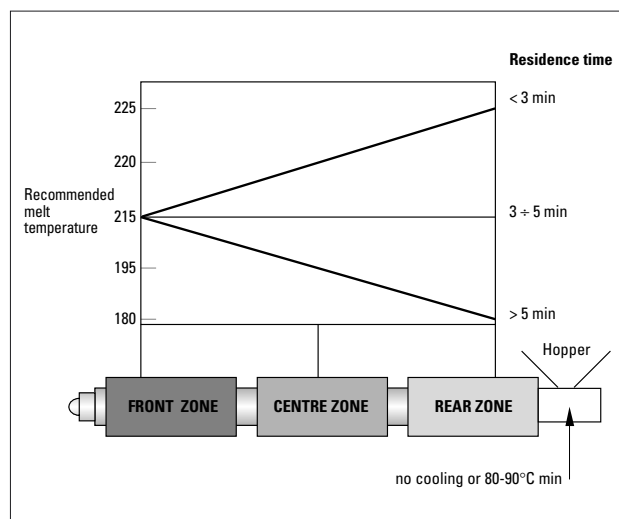

Fig. 5.01 **Cylinder temperatures profile vs. residence time for a given recommended melt temperature.** Recommended nozzle temperature is 190°C for all DELTRIN® grades

Notes:

1. As the preferred melt temperature for DELTRIN® 100ST and DELTRIN® 500T is about 10°C lower, the zone settings should be 10°C lower than shown in Fig. 5.01.
2. Hopper cooling is not needed and should not be used for DELTRIN®. As described in Chapter 3, excessive hopper cooling may create problems of screw deposit and black specks.
3. With very small injection units and/or short residence time (HUT), pre-heating the granules (e.g. with a heated hopper) may help to achieve an homogeneous melt.

Nozzle temperature

The nozzle temperature is adjusted to control drool and freezing (see page 12), but it should never be set above 190°C in order to prevent polymer degradation (the laminar flow and high viscosity of the molten polymer result in very long contact time with the metal wall). If the nozzle freezes with a setting of 190°C, its insulation from the sprue bushing should be improved, or its inside diameter should be increased if feasible.

Notes:

1. Practically, it is always easier to set the nozzle temperature correctly by using sprue break. The injection unit is pulled back after screw rotation and then the nozzle is insulated from the cold mould. This allows the calories to “flow” to the tip of the nozzle without having to set too high a temperature, and reduces the risk of stringing from the nozzle.
2. Hot runner. By analogy, a hot runner system is a nozzle transferring the molten resin from the injection unit to the part. Hence the principles and recommendations for nozzles are also valid for hot runners. In particular, the laminar flow and high viscosity of the molten polymer again result in very long contact times with the metal wall; so the temperature of the metal in the hot runner should never exceed 190°C, in order to prevent degradation of the polymer.

Screw Rotation Speed

Screw rotation speed behaves as a “thermal setting”, because the rotation of the screw will “shear” the material and supply around half of the calories needed to melt and heat DELTRIN® to the recommended melt temperature range of 215°C ± 5°C (205°C ± 5°C for DELTRIN® T and ST). As with all polymers, DELTRIN® is sensitive to shear and a maximum of 0,2 to 0,3 m/s of screw peripheral speed is recommended. The Fig. 5.02 shows the optimum screw rotation speed for high viscosity DELTRIN® (type 100P) and low viscosity DELTRIN® (types 500P to 900P) as a function of screw diameter.

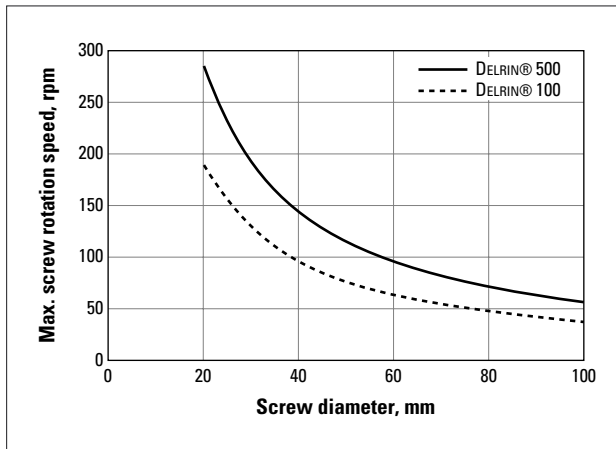

Fig. 5.02 Maximum screw rotation speed as function of screw diameter. The curve for DELRIN® 500 is also valid for the low viscosity grade DELRIN® 900

Back pressure

Back pressure also behaves like a thermal setting. Increasing back pressure increases the work done by the screw on the melt.

The use of the optimum screw design for crystalline materials, such as DELRIN®, should provide the necessary work to melt and bring DELRIN® to the recommended melt temperature with the minimum back pressure. Only melting of highly viscous DELRIN® such as DELRIN® 100 may require some back pressure to avoid the screw worming back (leading to inconsistent shot volume and pad).

The use of an inappropriate screw may require some back pressure to increase the work done by the screw on the melt, to increase the melt temperature and its uniformity. Higher back pressure may be used to eliminate unmelted particles and to improve colour mixing when colour concentrates are used. Increasing back pressure, however, tends to reduce glass fibre length and change properties of filled resins such as DELRIN® 570. More importantly, increasing back pressure always decreases the output of the screw, leading to longer cycle times and lower productivity. This increases the buildup of screw deposit leading to contamination and low part performance.

Therefore, back pressure should be used only when increasing cylinder temperature or other changes are not effective or possible.

For all materials, the back pressure used (specific or inherent to the injection unit) will create some pressure on the melt in front of the screw. To control drool at the end of the screw rotation, some suck back is required. This should be kept to a minimum.

Mould temperature

The best mould temperature for long term part performance would be just below the crystallisation temperature of DELRIN® e.g. 155° C. This temperature would allow the polymer to crystallise in an optimum state and eliminate any risk of re-crystallisation (post moulding shrinkage). Obviously it is economically impossible to set the mould at that temperature as the crystallisation time becomes almost infinite along with the cycle time.

Practically, a lower mould temperature is used, leading to shorter crystallisation time (HPT), hence shorter cycle time, lower mould shrinkage but higher post mould shrinkage (especially if parts are then exposed to elevated temperatures). A compromise should be found depending on the temperature in use and the required dimensional precision of the moulded part short and long term.

For standard DELRIN®, a mould temperature of 80-100° C is a good compromise for normal use, giving relatively short crystallisation time, high shrinkage but low post mould shrinkage (see Chapter 6: "Dimensional considerations"). A higher mould temperature will lead to higher mould shrinkage, longer cycle time but lower post mould shrinkage. It is specially recommended for high precision parts used at high temperature. A lower mould temperature leads to shorter cycle time, lower mould shrinkage but much higher post mould shrinkage leading to stresses and distortion.

For toughened resins such as DELRIN® 100ST and 500T, the use of a lower mould temperature (50° C ± 10) is acceptable without endangering long term part performances.

Note 1: "Mould temperature" is always the term used but the important parameter is the surface cavity temperature. With fast cycling operations, it may be necessary to use a lower mould coolant temperature to maintain the mould surface temperature in the recommended range. Chilled water is often used for very short cycles or to cool core pins and other mould sections that tend to run very hot.

Note 2: Coolant: Closed cooling circuits are the most common types used today. Coolants for closed circuits need to resist heat, freezing, pressure and vacuum. They should neither leave deposits in the circuit, nor corrode the cooling channels and tubes (tubes can be in steel, copper, plastic, rubber etc.). By analogy, the situation is similar to automotive engine cooling systems, and hence it is recommended to use the same fluid (anti-freeze + corrosion inhibitor) but in lower concentration. Initially the thermal exchange

is less efficient than with water, as the fluid is more viscous due to the glycol (more power is needed for turbulent flow). However, for long term use, a coolant (such as those used in cars) is the most effective solution (no corrosion or deposit, low erosion from cavitation).

In the case of coolants for open tower circuits, there is a need for chemical treatment to prevent build-up of micro-biological organisms that could cause disease and respiratory problems.

Operating conditions for DELRIN® – moulding cycle

Introduction

As mentioned in Chapter 2, the fact that DELRIN® is a crystalline material leads to a moulding cycle different from that of amorphous polymers. For DELRIN®, a moulding cycle generally consists of the following phases (see Fig. 5.03):

- A = *Mould open Time*. This includes the Opening Time, the Ejection Time and the Closing Time.
- B = *Filling Time or Injection Time*. Molten resin is introduced into the mould in a “dynamic filling phase”.
- C = *Hold (Pressure) Time*. During this “packing phase”, the resin is solidified under pressure, while additional resin is introduced into the mould to compensate for volume shrinkage occurring within the mould.
- D = *Screw Retraction Time*. The screw rotates and prepares new molten material for the next shot.
- E = *Cooling Time*. Since the part is crystallised (solid) and ready to be ejected at the end of the HPT, there is no need for a cooling time; hence the cooling time is only the Screw Retraction Time plus a short safety time.

The Overall Cycle Time (OAC) for DELRIN® is the addition of the various times set for each of the moulding operations.

Note: the above classification reflects the terminology used in the Computer Aided Moulding Diagnostic Optimisation (CAMDO) for DELRIN®. Frequently the sum of the Filling (Injection) Time and the Hold (Pressure) Time is defined as SFT (Screw Forward Time), as often stated in previous DELRIN® literature.

The cycle estimation graph in Fig. 5.04 shows a range of total cycle times that have been used for good quality moulding of DELRIN® in parts of various thickness. The actual cycle will be close to the lower limit when a high productivity resin such as DELRIN® 900 is used and when end-use requirements are less stringent.

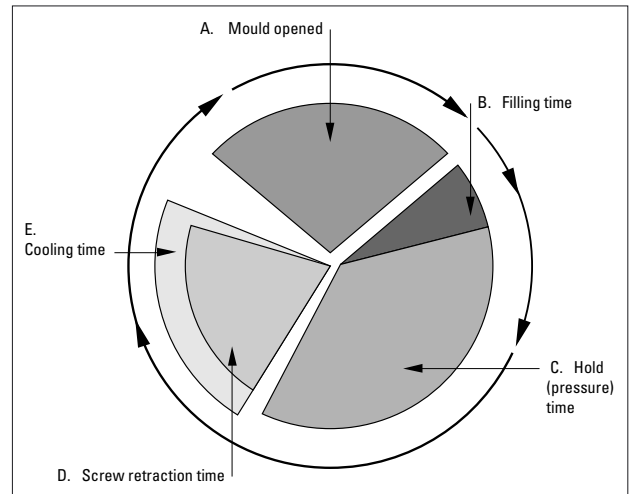

Fig. 5.03 The moulding cycle for DELRIN®

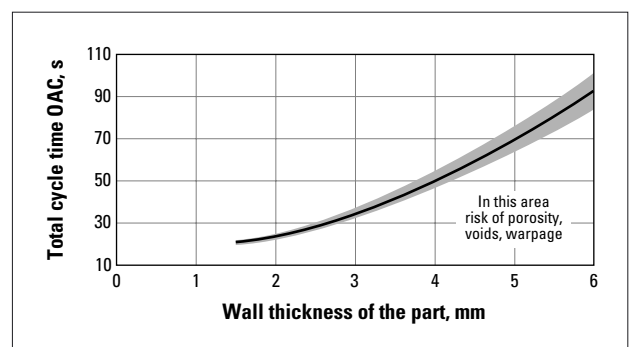

Fig. 5.04 Estimation of overall moulding cycle times for high quality moulding of DELRIN® parts

Filling phase

Injection Time

The optimum fill rate for a mould depends on the part geometry and thickness, the runner size, the size and location of the gate.

As rule of thumb, a filling time of 1 second per mm of part thickness is a good starting point for fill speed setting. The surface aspect will govern this adjustment. Higher and more uniform surface gloss can be obtained if the injection rate is fast enough to allow the cavity to be filled before the resin begins to solidify, although localised surface flaws, such as jetting and gate smear, are often reduced by decreasing the initial injection rate.

If maximum part toughness is required for the application, the shear applied to the material in the runner(s) and part should be checked to ensure optimum moulding performance and part properties.

The Fig. 5.05 shows the impact performance of a 2 mm part versus the shear during filling. If needed, please contact your DuPont representative to analyse your specific case.

Note: Minimising the shear in the gate can also be an important factor towards optimum part performance.

With non-optimum gate designs (conical, excessive gate length), shear in the gate may become an important limiting factor for part toughness.

With the optimum gate design presented in the mould design section (dimensions that allow optimum packing during crystallisation, gate length <0,8 mm), in most cases the shear at the gate has no effect on part performance. Flow analysis should be performed to check the shear at the gate for moulding very large parts only.

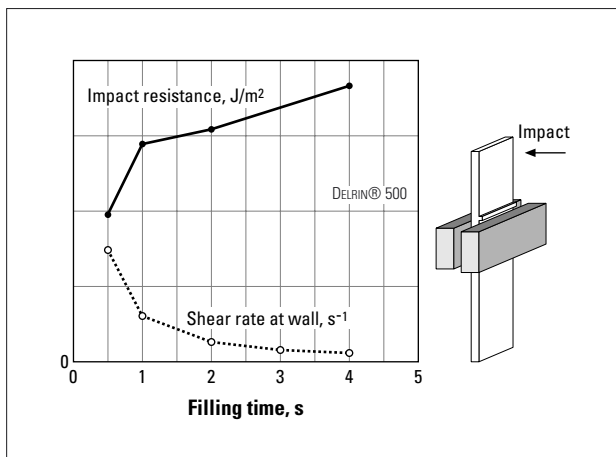

Fig. 5.05 Shear strain rate at the wall (s^{-1}) and impact resistance (J/m^2) as function of the filling time. This data was obtained with the sample shown (180 by 27 mm with 2 mm thickness). For impact resistance, the part is clamped under the rib and hit by a pendulum

Injection Pressure

This terminology often leads to misunderstanding.

The so-called “injection pressure” serves to move the screw and push the material in the mould. During this dynamic filling phase, the pressure built up in front of the screw is only equal to the pressure drop in the mould, from the nozzle to the position of the flow front. There is no pressure at the flow front itself during this dynamic filling phase.

Before the front of the flow reaches the end of the mould (when around 95% of the part volume is full), the machine should switch from dynamic filling (under velocity control) to quasi-static feeding (controlled by the “HOLD” pressure). This is the V-P switching point. The hold pressure will then be applied everywhere in the mould during the whole packing phase. For a crystalline material, more material ($\approx 14\%$ for DELRIN®) should be added to the part to “compensate” the crystallisation, leading to a slow screw forward movement during Hold (Pressure) Time.

With that definition, the injection fill pressure can be set to whatever value needed by the geometry of mould (including runners), as long as the filling rate is adequate for the part performance.

In case the V-P switch is incorrectly set (no switch or too late switch), the inertia of the system will create a pressure peak at the end of filling, leading to moulded-in stresses and flash. For that reason, in most practical cases it is safer to set the V-P switch point with distance rather than with pressure (as would typically be done for an amorphous material).

Packing phase

Hold Pressure Time (HPT)

The recommended Hold (Pressure) Time (HPT) for DELRIN® is the time for the molten polymer to fully crystallise in the mould cavity.

As the crystallisation (solidification) leads to a large volume drop ($\approx 14\%$, see Chapter 2), more melted material has to be pushed into the cavity during all the HPT.

This leads to special design rules for the gate and runners, as discussed in Chapter 4, so that the gate will not freeze before the cavity is properly packed.

The Hold (Pressure) Time is obviously a function of the part thickness. Fig. 5.06 shows the optimum HPT for DELRIN® 500 as a function of the part thickness (with the recommended Hold pressure of 85 MPa and the recommended mould temperature of 90°C).

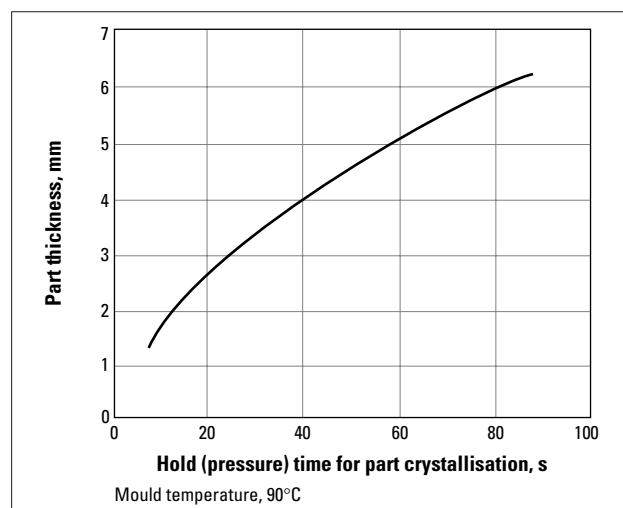

Fig. 5.06 Hold (Pressure) Time vs. part thickness of DELRIN® 500

Note: For the Eleven Series resins, the enhanced crystallisation leads to a shorter HPT of up 10%.

To check the efficiency of the HPT for a given part geometry, the traditional method is to plot the part weight as a function of the HPT. The maximum part

weight should correspond to the optimum HPT that can be read in Fig. 5.06 for the part thickness at the gate. At this time, the part is solidified and no more material can be added to the part. As an example, Fig. 5.07 shows the effect of Hold (Pressure) Time on part weight for a 4 mm thick ISO test bar. Fig. 5.07 also shows the evolution of part shrinkage with the HPT, which will be discussed in more detail in the next Chapter under "dimensional considerations".

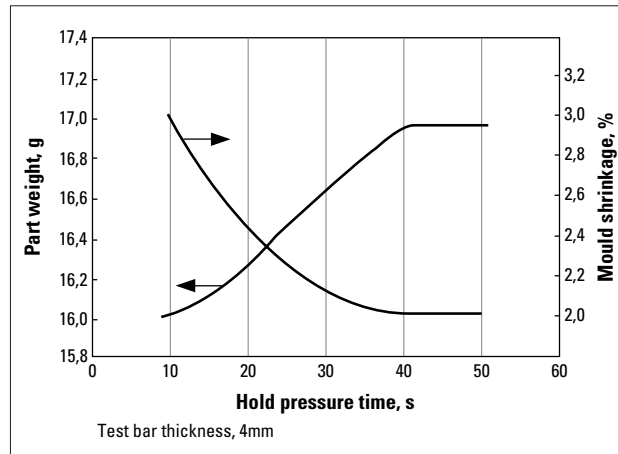

Fig. 5.07 Hold (Pressure) Time vs. part weight and mould shrinkage of DELRIN® 500

Another technique to define optimum HPT, using instrumented moulds, has been developed and is presented as an appendix at the end of this Chapter.

All the above considerations on HPT and its effects assume that the non return valve functions properly and maintains a cushion of melt in front of the screw as discussed in Chapter 3.

Too short or inefficient HPT leads to higher than normal and uncontrolled shrinkage. Additional side-effects such as voids, porosity, warpage, sink marks should be expected (see chapter "dimensional considerations").

Hold Pressure

Optimum hold pressures for DELRIN® acetal resins lie in a range of 60-110 MPa to achieve an homogeneous crystallisation. If higher or lower pressures are used in special conditions, they tend to lead to lower part performance. The following table shows the hold pressure range recommended for the various DELRIN® types.

Resin type	Grades of DELRIN®	Hold pressure (MPa)
High viscosity	100, 100P, 111P	90-110
Medium- and low-viscosity	500, 500P, 511P, 900P, 911P	75-100
Toughened	100ST, 100T, 500T	60-80

To obtain a homogeneous crystallisation, the hold pressure should remain constant until the part is fully packed (solidified).

Clamping force

This does not really belong to the description of the moulding cycle, but it is directly correlated to the hold pressure and for that reason it is discussed here.

The clamping force is the force required to keep the mould closed during filling and hold (pressure) time. This force is calculated by multiplying the projected area of the cavity (cavities), including runner system, by the maximum internal pressure (the hold pressure).

Commonly, moulds are set using the maximum clamping force of the moulding machine. However in many cases, the machine used has a much higher clamping force than actually needed. In these conditions, it is recommended to lower the clamping to the force actually needed by the mould (see calculation below). This will prevent excessive pressure at the parting line (compression of the vents, hobbing of the parting line, deformation of the mould components), leading to longer lifetime of the mould and less costly mould maintenance.

Estimating the maximum internal pressure can be done by carrying out a flow analysis. However, for parts with a flow length to thickness ratio less than 100 to 1, normally the internal pressure is equal to the hold pressure. The following guidelines can be used:

1. For parts needing optimum mechanical properties, the specific clamping pressure must be 1 ton/cm² for DELRIN® 100, and 0,85 ton/cm² for other DELRIN® grades.

Example calculation:

- Projected area of part (or parts), including runner system = 115 cm².
- Material = DELRIN® 500.
- Machine clamping force required =
 $115 \times 0,85 = 98$ tons.

2. For parts not requiring optimum mechanical properties, it may be possible to mould acceptable parts with lower specific hold pressures (and lower clamping forces).

Plastification phase

Screw retraction time

Given a fixed amount of resin to plasticise for the next shot, the screw retraction time is directly dependent on the screw rotation speed.

It is crucial to check that the applied screw rotation speed is low enough to avoid over-shearing the resin in the barrel (which may lead to degradation), but high

enough to provide a homogeneous melt (with no unmelted particles). This can be done with the two practical tests for the presence of unmelt and degraded material, as described at the end of Chapter 3.

Note: since DELRIN® is a highly crystalline polymer, its thermal requirements are different from those of amorphous materials. Screws specifically designed for DELRIN® and an appropriate ratio of shot weight to machine capacity provide an efficient plastification. More details about screw dimensions are given in Chapter 3.

Cooling time

The cooling time is an important parameter for the injection moulding of amorphous polymers. The situation is completely different with DELRIN® (see also Chapter 2). At the end of a correctly set and efficient hold pressure time (HPT), the DELRIN® part is crystallised and solid. There is no need for further cooling time, and the part could in principle be ejected immediately from the mould. This can be demonstrated by stopping the cycle at the end of the HPT and ejecting the part immediately.

In most practical cases the part is ejected after the screw retraction time, so the cooling time (as defined in Fig. 5.03) is simply the screw retraction time plus a small safety margin. An exception is the case of machines with shut-off nozzles, where part ejection can take place during the screw rotation. This theoretically gives shorter cycles, although practical problems may arise and limit productivity (see Chapter 3 for more details on shut-off nozzles).

Optimum productivity moulding

Economic constraints are pushing for lower part cost, which can be reached by increasing the yield of quality parts and/or shortening the Over All Cycle time. This guide recommends the parameters to achieve optimum part properties in the short and in the long term, leading to an optimum OverAll Cycle time (OAC).

Any modification to the cycle should be done only after realistic evaluation of part performance short AND long term. Decreasing the cycle too much may lead to a) lower part properties and other quality problems (especially shrinkage, warpage and post shrinkage), and b) process not running in a "robust" area, which could lead to lower yield of quality parts and higher part cost.

Before trying to shorten the current OAC, the following items should be considered:

- The design of the part may not be optimum, i.e., the part may be too thick. Changes to the design

(adding ribs, use of pins) are costly but may allow significant reduction of the cycle time.

- The design of injection unit may not be optimum. With DELRIN® the cooling time can be minimised to the time required for proper screw retraction. Optimum screw size and design will facilitate this.
- The sorting of parts from runners may not be optimised.

Having decided to decrease the OAC, the following actions may be carried out (in order of increasing risk):

- Investigate obvious bottlenecks in the cycle.
- Minimise the Mould Open stroke.
- Minimise the Mould Open time by increasing the opening/closing speeds. Rubber bumpers or springs can be used to prevent banging of the floating plate in 3-plate moulds, giving no effect on part quality.
- Minimise time between the screw stopping and the mould opening. No effect on part quality.
- Minimise Filling Time (faster injection fill). It may result in overshearing and decreased weld line strength. Larger nozzle and runners, as well as improved venting may be required.
- Decrease Screw Retraction Time:
 1. Use a larger screw and limit the stroke to between 1 and 2 screw diameters, no effect on part quality.
 2. Use an optimised screw design for DELRIN® (screw for crystalline polymers with correct depth of metering zone, mixing head). This ensures a homogeneous melt even at high screw rotation speeds, hence there are no effects on part quality. Using higher screw rotation speeds with a general purpose screw would reduce SRT, but with the risk of poor melt quality and part failure.

Note: as there is no need for cooling time, shutoff nozzles (where the screw can be rotated during mould opening) have been tried. Unfortunately, problems such as wear, contamination, hold up spots etc. have been observed, and no long-term satisfactory solution was found.

- Decrease Hold Pressure Time. With a lower than optimum HPT, higher mould shrinkage and deformation leading to warpage will be seen. Voids will also be formed in the centre of the part, leading to lower mechanical properties (lower elongation at break), and quality control should be carried out on larger lots of moulded parts. If the mould temperature is decreased as an attempt to compensate for the shorter HPT, this action will lead to a lower mould shrinkage but will result in very high post moulding shrinkage, deformation and warpage.

Standard moulding conditions for ISO tensile bars

Standard processing parameters to injection mould DELRIN® into tensile bars ISO 294-1 are shown in Table 5.01. They can help moulders in establishing moulding parameters when processing DELRIN® acetal resins. However it must be emphasised that for parts of different shapes and dimensions such parameters should be modified using the information presented below.

Appendix: Hold Pressure Time via in-cavity pressure measurement

This technique has been developed during recent years, particularly for amorphous resins. The main objective was to optimise and control the hold pressure profile in order to reduce internal stresses, which have been a frequent cause of failure of moulded articles in amorphous polymers.

Even if such problems of internal stresses do not apply to a crystalline polymer like DELRIN®, this technique is proving to be an effective method to determine the crystallisation time (HPT) of a part moulded with a specific polymer grade at given processing parameters.

A flexible data acquisition system has been set up by DuPont. It consists of a computer with a data acquisition card and proprietary software CAVAN (CAVity ANalysis), and allows all available analog signals (e.g. injection fill speed, hydraulic pressure etc.) to be acquired, displayed and analysed. The system measures the crystallisation time of each cycle with a precision, depending on the sensor location, down to 0,1 second.

A single pressure sensor close to the gate is usually sufficient to determine the crystallisation time of a DELRIN® part. This is done within a single moulding cycle, by analysing the pressure changes during the packing phase. Figure 5.08 shows a typical CAVAN curve from which the Hold (Pressure) Time of a 2 mm thick DELRIN® part can be determined.

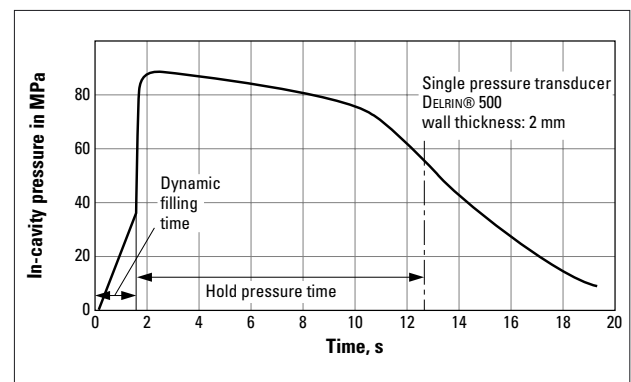

Fig. 5.08 Cavity pressure measured during the filling and packing (1 sensor)

Table 5.01 Processing conditions for ISO 294 tool (insert type A)

Resin grade	DELRIN® 100, 111P	DELRIN® 500, 511P 900, 911P	DELRIN® 100ST	DELRIN® 500T
Characteristics	High viscosity acetal resin	Medium and low viscosity acetal resin	Super tough high viscosity acetal resin	Toughened medium viscosity acetal resin
Pretreatment:				
Moisture level for processing	<0,2%	<0,2%	<0,05%	<0,05%
Drying temperature (°C)	80	80	80	80
Drying time (h)	2 h	2 h	4 h	4 h
General parameter:				
Type of screw	HC screw	HC screw	HC screw	HC screw
Max. screw tangential speed (m/s)	0,2	0,3	0,15	0,3
Melt temperature (°C)	215 ± 5	215 ± 5	205 ± 5	205 ± 5
Mould temperature (°C)	90 ± 10	90 ± 10	50 ± 10	50 ± 10
Hold pressure (MPa)	90 – 110	75 – 100	60 - 80	60 – 80
Back pressure (MPa)	<1,0	<0,25	<1,0	<0,25
Specific parameters (insert A):				
Injection fill time (s)	1 – 5	0,5 – 2	0 – 5	0,5 – 2
Flow front velocity (mm/s)	40 – 200	100 – 400	40 – 200	100 – 400
Hold Pressure Time (s)	35 – 45	35 – 45	25 – 35	25 – 35
Cycle time (s)	40 – 60	40 – 60	35 – 50	35 – 50
Conditioning	24h at 23 ± 2°C and 50 ± 5% RH	24h at 23 ± 2°C and 50 ± 5% RH	24h at 23 ± 2°C and 50 ± 5% RH	24h at 23 ± 2°C and 50 ± 5% RH

6. Dimensional considerations

DELTRIN® resins have good dimensional stability, compared to other polymers, over a wide range of temperatures and in the presence of moisture, lubricants or solvents. They find extensive use in industry for the fabrication of precision gears, bearings, housings and similar devices, because of their unique combination of dimensional stability with other properties, such as fatigue resistance and tensile strength. However, as with all materials of construction, there are factors affecting the dimensional stability of DELTRIN® which must be considered when close tolerances are essential.

The dimensions of a moulded part are determined primarily by the dimensions of the cavity, and secondly by all those variables that affect resin packing and crystallinity (for example hold pressure, HPT, mould temperature). It may seem obvious to mention cavity dimensions as the main factor for part dimensions; however experience has demonstrated that dimensional problems are often addressed by changes in moulding conditions, generally with a limited success. Isotropic dimensional problems can in principle be corrected by changes to hold pressure. In the more frequent cases where a few dimensions are out of specification, attempts to correct with the moulding parameters generally greatly reduce the acceptable processing window, leading to a higher risk of rejects.

Mould shrinkage and post-mould shrinkage occur as natural consequences of the moulding process. They influence the tolerances that can be obtained for moulded parts. Data on these effects are presented in this Chapter.

Further dimensional variations in moulded parts of DELTRIN® can arise from changes in the temperature or nature of the surroundings. Reversible changes result from thermal expansion or contraction and from absorption of water or other solvents. These are discussed later in this section, under "Environmental Changes."

Irreversible changes in dimension occur when polymer chains frozen in an unstable condition move towards a more stable state. An example is when parts moulded in a tool at low mould temperature are exposed to elevated temperatures. These changes are discussed under "Post-Mould Shrinkage" and "Annealing."

Mould shrinkage

Mould shrinkage is the shrinkage that occurs within 24 hours of moulding. It is defined as the difference between cavity and actual part dimension, both measured at room temperature. It is due to the difference in specific volume of DELTRIN® at the crystallisation temperature and its specific volume at room temperature (see Chapter 2, PVT diagrams).

The typical mould shrinkage of DELTRIN® resins is between 1,8 and 2,2%, except for the supertough and fibre-containing grades (DELTRIN® 100ST, 500AF, 570 and 577) which have a lower shrinkage.

Table 6.01 summarises the average mould shrinkage of a 4 mm thick part moulded in the specific recommended conditions. These values should be considered as an approximate guide only, because the shrinkage for an actual part depends on its design and on the moulding conditions, as described in more detail below.

Table 6.01 Average mould shrinkage for various grades of DELTRIN®

DELTRIN® grade	Average mould shrinkage	
	in flow (% ± 0,2%)	transverse (% ± 0,2%)
100, 100P	2,1	1,9
500, 500P	2,1	2,0
511P, 911P	1,9	1,8
900P	2,1	2,0
colours*	1,8–2,1	1,7–2,0
500T	1,8	1,7
100ST	1,3	1,4
500AF	2,1	1,5
500CL	1,9	1,9
570, 577	1,2	2,1

* depends on the pigments

Table 6.02 Key parameters affecting mould shrinkage

Parameter	Effect on shrinkage	Remarks
Hold (Pressure) Time (HPT)	▲	up to optimum HPT, then no effect
Hold pressure	▲	
Mould temperature (cavity)	➤	but post-mould shrinkage ▲
Part thickness	➔ or ▲	if all settings optimised
Gate thickness	▲	up to optimum thickness, then no effect
Melt temperature	➔	if mould temperature is kept constant and HPT is optimised

Symbol ➤ means that the shrinkage increases when the value of the parameter increases, and the opposite for the symbol ▲.

Symbol ➔ means that there is no effect on shrinkage provided that the conditions listed under "Remarks" are met.

Factors affecting mould shrinkage

Mould shrinkage is dependent on the factors that affect the crystallinity of DELRIN®. These include:

- Hold Pressure;
- Hold (Pressure) Time;
- mould Temperature;
- part thickness;
- gate dimensions.

Table 6.02 summarises the effect of these parameters on mould shrinkage. They are discussed in more detail below.

Furthermore, mould shrinkage is also highly dependent on the geometry of the part and on the flow pattern of the resin. Experiments have been done in our Laboratory with 180 × 27 mm plaques with thicknesses from 1,5 to 6 mm. Four values of shrinkage were measured, close to and far from the gate, parallel and perpendicular to the flow. For most DELRIN® grades it is observed that the shrinkage is higher far from the gate than close to the gate (typically by 0,1 to 0,3%), and that the shrinkage in the flow direction is about 0,1% higher than transverse to the flow.

Hold Pressure

Injection pressure has two functions in the moulding process:

1. Transfer the molten polymer from the injection unit into the mould. This “injection fill pressure” is needed only to overcome the resistance to flow of the polymer from the injection unit to the cavity. Usually this is a high speed process (dynamic phase of the screw).
2. Control the packing and crystallisation process. The hold pressure pushes more material into the cavity to compensate for the volume reduction that occurs in the polymer during crystallisation. This is a low speed process (slow motion of the screw). This phase is more important for the dimensional stability since it helps maintain a uniform and gradual crystallisation. When a lower hold pressure is used, it will pack less material into the cavity and the shrinkage will be higher. This is shown in Fig. 6.01 for three mould temperatures.

Small changes of hold pressure may be used to help fine tune the dimensions of a part, because this parameter is essentially independent and has relatively small adverse effects.

Note that hold pressure should be constant during the whole packing time.

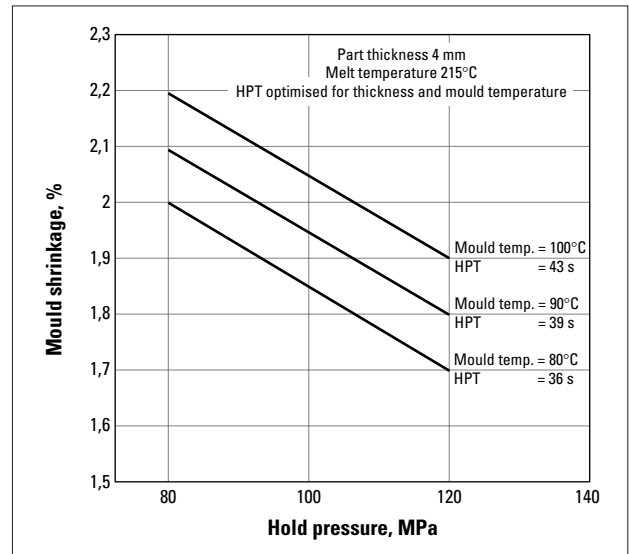

Fig. 6.01 Effect of hold pressure on mould shrinkage at three mould temperatures, for DELRIN® 500. Hold pressure can be used for small adjustments of part dimensions, as it has negligible effect on post-moulding shrinkage

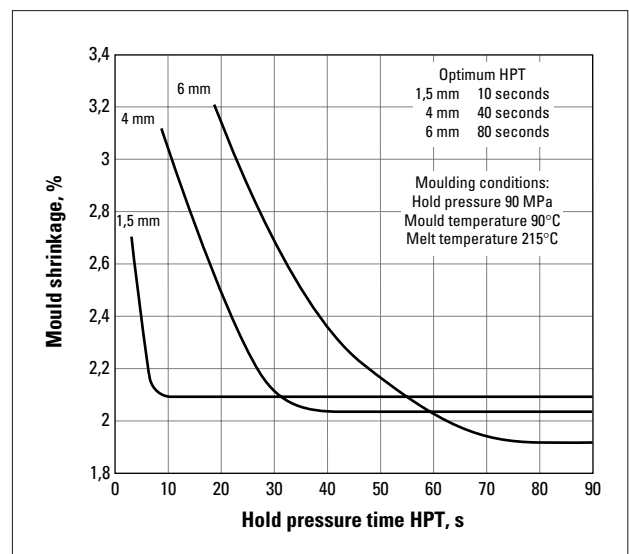

Fig. 6.02 Effect of Hold (Pressure) Time on mould shrinkage of DELRIN® 500P

Hold (Pressure) Time (HPT)

Hold (Pressure) Time is the time during which the hold pressure is applied. The HPT is important for the value of shrinkage and its uniformity over the part.

Fig. 6.02 shows the effect of HPT on mould shrinkage for DELRIN®.

When the HPT is below the optimum value required for the specific part (as determined in Section 5), the packing process is interrupted before completion and mould shrinkage is higher than its optimum value. Additional side-effects of a short HPT are porosity, voids, warpage, sink marks, lower mechanical properties.

On the contrary, any increase of HPT above its optimum value would have no effect on mould shrinkage, because the part (and the gate) are already solidified.

Mould temperature

Mould temperature influences mould shrinkage through its effect on cooling rate and crystallisation temperature of the molten polymer. The effect of mould temperature on shrinkage is also shown in Fig. 6.01.

At high mould temperatures, the polymer crystallises slowly. In such conditions the mould shrinkage is high, but since the crystallisation is more complete, a better long-term dimensional stability is to be expected for the moulded parts (less post-mould shrinkage).

Low mould temperatures, on the other hand, tend to cool the polymer at a very high rate. This results in a lower mould shrinkage and better toughness. However, in the long term, higher dimensional variations leading to build up of internal stresses will occur, particularly if the part is exposed during its end-use life to temperatures exceeding the mould temperature at which the part was moulded.

Part thickness

As shown in Fig. 6.02 for DELRIN® 500, the thickness has a minor influence on mould shrinkage, provided that the gate dimensions and the Hold (Pressure) Time are correct for each thickness. Fig. 6.03 shows the shrinkage of various DELRIN® compositions vs. part thickness, as measured with correct HPT. Note that, to optimise toughness, the mould temperature is reduced from 90° C for the standard grades to 50° C for the toughened grades (without leading to a high post-moulding shrinkage).

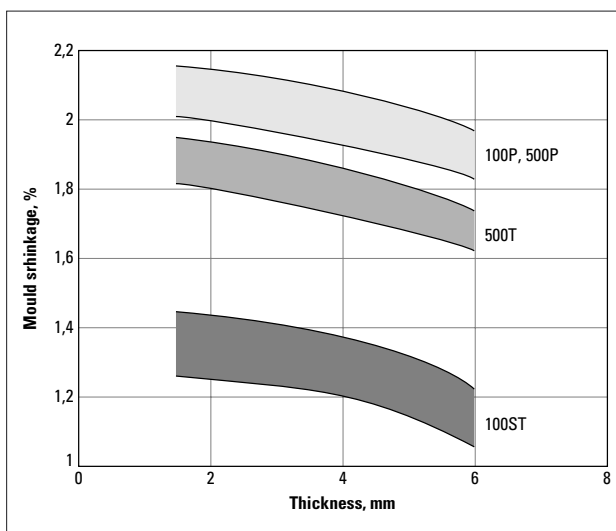

Fig. 6.03 Average mould shrinkage vs. thickness, for various DELRIN® compositions

For parts of uniform wall thickness, the mould shrinkage tends to be uniform. In the case of variable thickness, shrinkage will tend to be nearly uniform if the part is gated into the thickest section, if the gate is properly sized and if the Hold (Pressure) Time equals or exceeds the gate freeze time. When these criteria are not met, the mould shrinkage tends to be greater for larger sections, with possible problems of voids, warpage, sink marks and lower mechanical properties.

Gate dimensions

Adequate gate dimensions are required to ensure proper packing of the part (see Chapter 4).

When the thickness of the gate is smaller than its optimum value, mould shrinkage will increase due to the premature solidification of the resin at the gate. This situation is then equivalent to a shorter Hold (Pressure) Time, and the approximate effect on shrinkage can be observed on Fig. 6.02. In this range the mould shrinkage is not stable, and it is very difficult to control. The resulting warpage could even make difficult the measurement of certain dimensions of the part.

Melt temperature

Melt temperature has an effect on mould shrinkage. It is however limited by the narrow range of melt temperatures needed to maintain a consistent quality of the moulded part. Consequently, the melt temperature should not be considered as a variable to adjust mould shrinkage.

Mould shrinkage of filled resins

The mould shrinkage of compositions containing fibrous fillers, such as DELRIN® 570 (glass) and DELRIN® 500AF (TEFLON®), is less predictable, because of the fibre orientation effects. The shrinkage in the direction of flow tends to be significantly different from that in the transverse direction (see Table 6.01).

In general, the mould shrinkage of DELRIN® 500AF in the flow direction is similar to that of DELRIN® 500. The mould shrinkage in the transverse direction, however, ranges up to 50% of the shrinkage of DELRIN® 500.

In contrast, the mould shrinkage of DELRIN® 570 in the flow direction is about half of that for DELRIN® 500. In the transverse direction, the mould shrinkage of DELRIN® 570 approaches that of DELRIN® 500.

Effect of pigments

The presence in the melt of crystallisation nuclei such as pigments and regrind can have an influence on crystallisation and consequently on mould shrinkage.

An accurate study has been carried out to evaluate the effect of various types of pigments on the mould shrinkage of DELRIN®. It appears, as depicted in Fig. 6.04, that pigment systems giving the same resin colour may have a different effect on mould shrinkage and part dimensions.

Note: This study has been carried out on standard bars and in typical moulding conditions. The shrinkage values shown here should not be considered valid for all parts of different geometry and/or moulded in different moulding conditions.

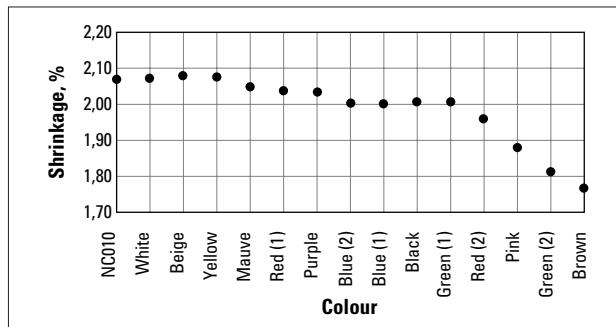

Fig. 6.04 Effect of selected pigments on mould shrinkage of DELRIN® 500. Part thickness 2 mm

Post-moulding shrinkage

Post-moulding shrinkage is defined as the shrinkage which takes place more than 24 hours after moulding. It is a consequence of continued crystallisation and relaxation of moulded-in stresses, where the resin moves towards a more stable state. This happens because the glass transition temperature of DELRIN® is well below room temperature.

The post-mould shrinkage of parts moulded in DELRIN® can be estimated from Fig. 6.05.

Parts moulded with the recommended mould temperature (90° C) or higher will have a low post-mould shrinkage, which ensures good dimensional stability over the lifetime of the part.

However, parts moulded with a cold mould (<80° C) will have a higher post-mould shrinkage, because fast cooling leaves the DELRIN® in an unstable crystalline state and results in more significant recrystallisation. If such DELRIN® parts are then exposed to high temperatures, the re-crystallisation causes a high and rapid post-mould shrinkage.

Remarks:

1. For parts requiring tight tolerances and exposure to elevated temperatures for prolonged periods of time, it is strongly recommended to use high mould temperatures (up to 120° C). This provides a more effective solution than annealing a part moulded at low mould temperature.

2. For exposure at moderate temperatures, good dimensional stability and part performance can be achieved using a 90° C mould temperature.

Insert moulding

Almost all the problems of insert moulding are linked with shrinkage around the insert, mould shrinkage and post moulding shrinkage. To minimise total shrinkage, the following should be taken into consideration:

- High mould temperatures should be used (90° C or above) in order to minimise the total shrinkage (sum of mould shrinkage and post-mould shrinkage). At lower temperatures the mould shrinkage is indeed smaller, but the post-mould shrinkage is much higher.
- Optimum Hold (Pressure) Time for the part thickness, to minimise part shrinkage. The shrinkage increases dramatically with shorter HPT (see Fig. 6.02).
- Inserts should be pre-heated to the same temperature as the mould. This is very important for large inserts.
- Inserts should be free of sharp corners and contamination.
- To minimise cracking, high-viscosity DELRIN® is recommended due to its higher elongation.

Note: If a cracking problem cannot be overcome by using the above measures, other inserting techniques should be evaluated, such as insertion after moulding by press-fitting, insertion by sonic energy, or a self-tapping insert.

Annealing

Annealing is occasionally used to accelerate stress relaxation and dimensional stabilisation of parts. It is a complex process and should only be used when moulded parts require very tight tolerances and exposure to high temperatures for prolonged periods.

Annealing is also suggested as a test procedure in setting up moulding conditions on a new mould, to evaluate post-moulding shrinkage and moulded-in stresses. The changes in dimensions during annealing will closely represent the ultimate change in part size in use.

When dimensional precision is a prime requirement, the use of a high mould temperature (90-120° C) is strongly recommended. Attempts to reach good dimensional stability by annealing parts moulded in a cold mould (<80° C) will lead to high post-moulding shrinkage and may introduce stresses during the re-crystallisation process, resulting in uncontrolled deformation.

Annealing procedure

Annealing should be performed in air or in inert mineral oils at $160 \pm 3^\circ\text{C}$, for 30 minutes + 5 minutes per mm of wall thickness. Overheating and hot spots should be avoided, and parts should neither contact each other nor the walls of the oven/bath. Parts should be left in the oven to cool slowly until 80°C is reached. Stacking or piling, which may deform the parts while they are hot, should be delayed until the parts are cool to the touch. This procedure was used to obtain the results shown in Fig. 6.05, and permits evaluation of the ultimate dimensional changes that a part is likely to experience in normal use.

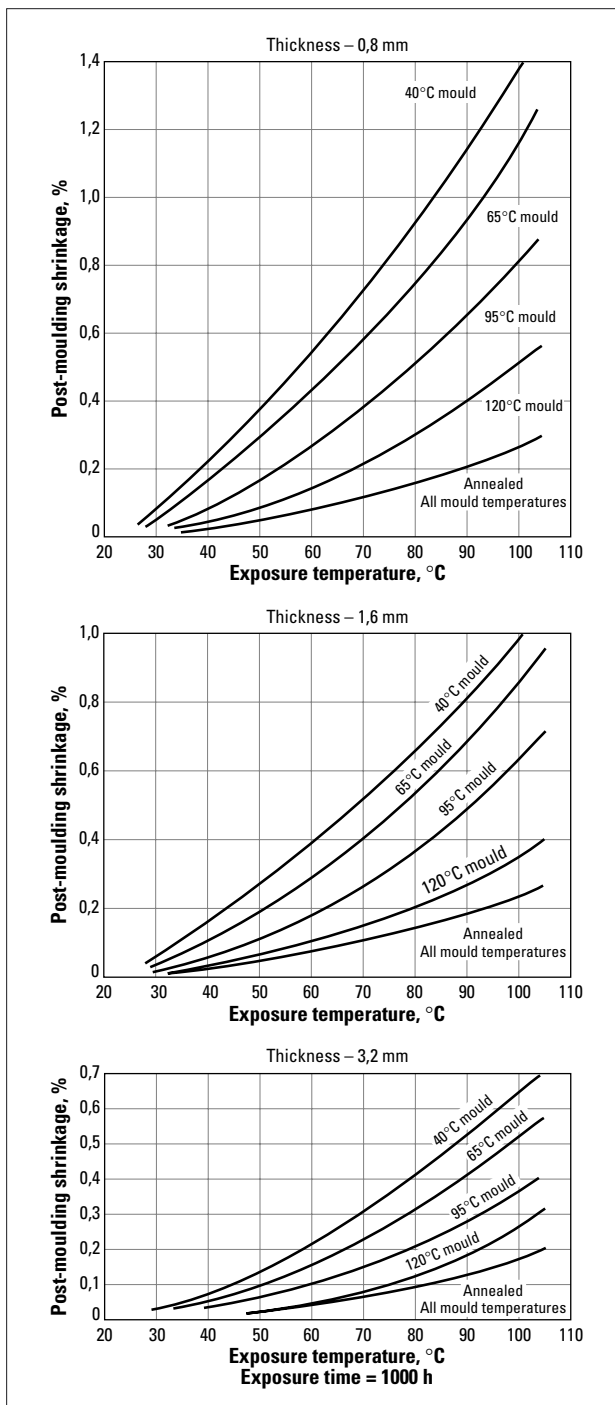

Fig. 6.05 Post-moulding shrinkage of DELRIN® acetal resins

To simply stabilise parts for continuous high temperature use ($<90^\circ\text{C}$), parts may be heated to 90°C for up to 24 hours. Post-moulding shrinkage of around 0,1 to 0,2% will then be seen if the parts were moulded in a mould at $90^\circ\text{C} \pm 10^\circ\text{C}$.

Environmental changes

Part dimensions of DELRIN® acetal resin change with the environmental temperature and with the absorption of small amounts of water. Data concerning dimensions for various DELRIN® acetal resins are plotted in Fig. 6.06, which combines the effects of moisture content and temperature. The graph shows several lines representing different exposure conditions with respect to moisture (50% RH, 80% RH, 100% RH, and immersion).

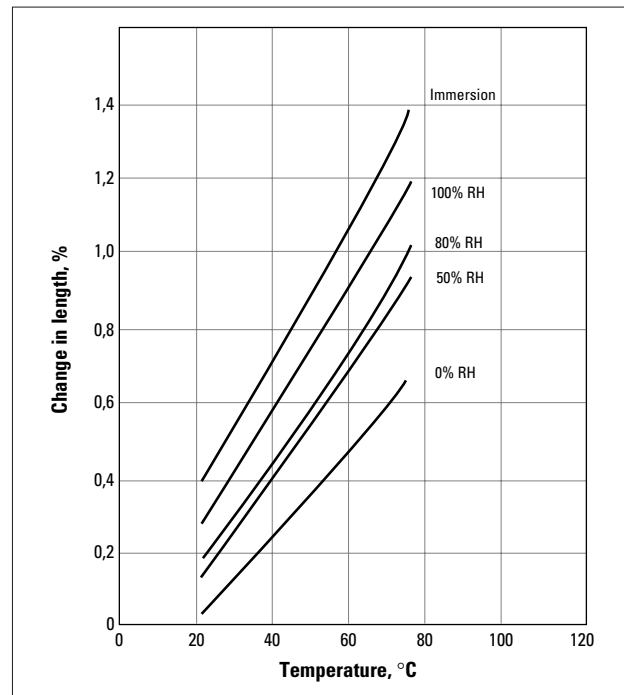

Fig. 6.06 Environmental dimensional change of DELRIN® 100 and 500

Dimensional tolerances

General

Taking into account mould dimensions and processing variability, experience suggests that the following dimensional tolerances are achievable with good moulding practice:

- dimensions up to 150 mm:
 - ±0,15% for precision moulding
 - ±0,3% for technical moulding
- dimensions above 150 mm:
 - ±0,25% for precision moulding
 - ±0,4% for technical moulding

Moulds

For multi-cavity moulds, the tool making tolerances are important. They have a direct effect on the dimensional tolerance of the part. As an example, for a mould dimension of 30 mm manufactured to within $\pm 0,01$ mm, experience has shown that dimensional consistency better than $\pm 0,03-0,04$ mm cannot be expected for parts from different cavities in a single shot.

Moulding conditions

Parts moulded under recommended conditions (gate, runner, nozzle, screw, machine parameters) as defined in the moulding guide are subject to small shot to shot variations in dimensions. Any change in machine parameters or conditions will effect dimensional tolerance. For example, a colder mould leads to higher post-moulding shrinkage, too short Hold (Pressure) Time leads to inconsistent shrinkage, deformation and larger variability in part dimensions.

7. Auxiliary operations

Several auxiliary operations associated with the moulding of DELRIN® acetal resins are discussed in this section. They include the following subjects:

- Material handling.
- Drying.
- Reground resin.
- Colouring.
- Disposal.

Material handling

DELRIN® acetal resin is shipped dry and need not be dried before moulding. Resin that has been stored in a cold warehouse area should be brought to room temperature prior to moulding. This will prevent moisture condensation and variations in heat required to melt and thus in melt temperature.

Particular care is required for the toughened compositions of DELRIN®. Bags of DELRIN® 500T, 100T and 100ST should not be opened until they are ready to be used. If a bag is opened for any significant period of time and the resin has picked up moisture, the material should be dried before it is moulded (see below).

Pellets of DELRIN® are surface lubricated with ethylene di-stearamide. Further lubrication of these compositions is not necessary.

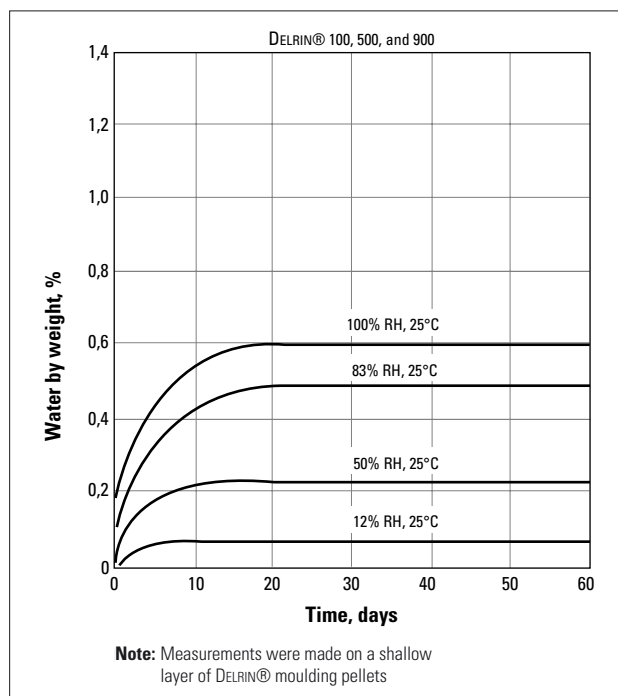

Fig. 7.01 Rate of water absorption at various conditions

Drying

As a general rule, DELRIN® does not require drying. However drying is recommended in some cases.

Standard grades:

- When a resin container stays open for a significant time, drying at 80° C for two hours may improve the melt quality. The water absorption rate of DELRIN® acetal resins at various humidity levels is shown in Fig. 7.01.
- When using more than 50% of the capacity of the machine, preheating the resin at 80° C for two hours may improve the homogeneity of the melt and decrease the torque on the screw.
- When thermal stability is a concern (e.g. with some difficult colours), blowing air at 80° C through DELRIN® may help. This will result in less mould deposit and better surface finish.

Toughened grades:

Moulding of toughened DELRIN® compositions with excessive moisture (>0,05%) has a negative effect on toughness. Therefore, it is recommended that the resin is dried for 4 hours at 80° C in a dehumidified dryer (see the drying behaviour of DELRIN® 100ST in Fig. 7.02).

At 23° C and 50% R.H., DELRIN® 100ST picks up 0,1% moisture in 4 hours; at 30° C and 85% R.H. it will pick up 0,3% moisture in 2 hours. For this reason runners and sprues should be reground and reused as soon as possible.

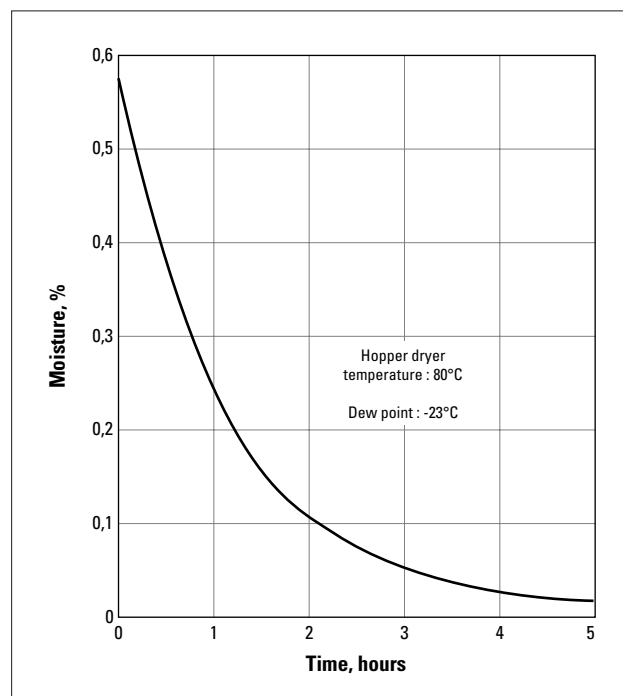

Fig. 7.02 Drying behaviour of DELRIN® 100ST

Reground resin

Recommendations to regrind DELRIN®

The recommendation is based on actual studies conducted at DuPont's Technical Service Laboratory (TSL) in the USA, the European Technical Center (ETC) in Geneva and in the field.

This section answers questions about the remoulding of sprues and runners. Adherence to the practices given, should make it possible to produce parts in DELRIN®, using regrind, with generally good physical and mechanical properties. In addition, it will help avoid the problems of odour, poor flow in the mould, splay, black specks and surface wrinkles.

The use of contamination free and uniformly reground DELRIN® has almost no influence on mechanical properties and moulding performance of standard grades (see details below). To regrind the material properly, the following should be considered.

Handling of scrap

The scrap coming from manual cutting or directly from an automatic mould should be carefully handled to prevent any possible external contamination such as oil (from the machine), sawdust, normal dust, scrap of other resins, degraded resin and so forth.

Storage of scrap

Storage of scrap in a clean and dry place is desirable to prevent dirt contamination (DELRIN® parts tend to pick up dirt and dust by electrostatic attraction) and moisture pick up (i.e. condensation on the container used). These objectives can be met by storage of the scrap in closed containers.

Note: Open bags of DELRIN® do not necessarily have to be resealed, just carefully closed again.

Grinding of scrap

Two types of grinding equipment are in general use: bead cutters and chunk cutters. The bead cutters are useful only for beading, tubing and small shapes. Other small scrap products must be sawed into small pieces before they can be fed into the cutter. The size of the granules of the cut scrap is regulated in the chunk cutter by the hole size of the screen below the knives. Since the size of the cut particles affects the regularity of feeding and plasticization of the melt, the knives should be maintained as sharp as possible. This will also minimize the amount of fines produced during grinding.

For cutting a hard and tough material such as DELRIN®, the cutter must have sufficient power. For example, a large section of about 4,7 mm thick (3/16 in.) gave trouble in jamming a cutter with a 5 HP motor, but no trouble for a cutter with a 10 HP motor.

Lubrication of regrind

Virgin DELRIN® moulding compound contains a surface lubricant to improve slippage and decrease the pressure loss, especially for ram machines. This lubricant is lost after one pass through the moulding machine. Usually relubrication is necessary only when working with a ram machine. It is usually not required for screw injection moulding machines.

The lubricant we use for DELRIN® is "ACRAWAX" C*. The concentration of "ACRAWAX" C is approximately 0,3 g/kg of DELRIN® regrind. Standard drum tumbling equipment is satisfactory. A blender should be loaded to 50-60% of capacity, and blending times kept to a minimum (5 to 10 min).

Moisture of regrind

DELRIN® virgin resin absorbs moisture from the atmosphere (Fig. 7.03). Tests have shown that moisture levels less than appr. 0,25 per cent do not cause any trouble. In order to minimize the moisture pick up of reground and so avoid drying, the following points should be observed:

1. The regrind must be screened from the fines coming from the cutting operation. Those fines being very small will pick up moisture very rapidly. In addition, they usually contain the bulk of any contamination in the regrind and interfere with proper feeding of the polymer to the moulding machine. We recommend the use of a 12 mesh screen for removing these fines**.
2. The regrinds must be stored in dry containers, which should be closed (not necessarily sealed).

Fig. 7.03 next page, shows the rate of water absorption of a shallow layer of DELRIN® moulding powder. In the laboratory, tests were carried out with a screw injection machine to determine the highest permissible moisture level on DELRIN®. The criteria were that drooling, splay, gassing or leakage occurred whenever moisture levels were too high.

Drying of regrind

Drying of virgin resin or rework is not ordinarily required. These suggestions are made to take care of exceptional cases. Regrind, or virgin resin, is easily dried in a circulating air oven in 4 hours or less at 85° C. In tray ovens the layer of material should be no more than 25 mm. thick to permit efficient drying in the minimum time and thereby minimize surface oxidation.

* ACRAWAX C is a product from GLYCO Product Company, New York, USA.
** One type of equipment is a Witco Vibratory Screen (SWECO-Southwest Engineering Co., Los Angeles, California, USA).

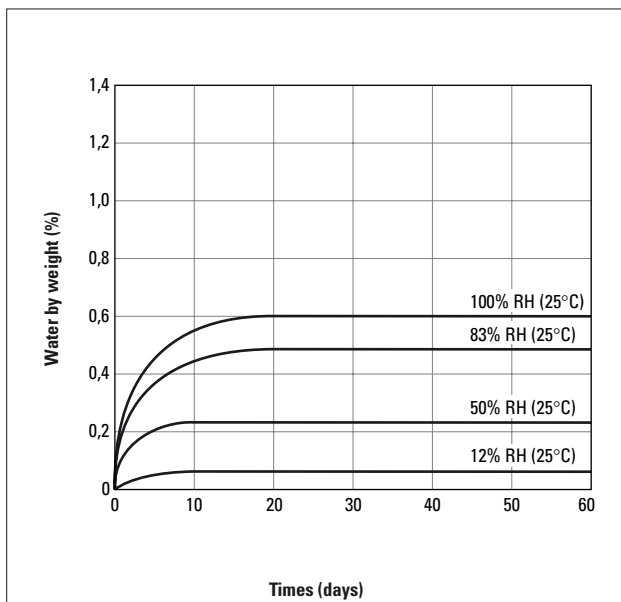

Fig. 7.03 Rate of water absorption at various conditions

Percentage of regrind

Laboratory tests have been conducted to determine the maximum percentage of regrind allowable. Polymer has been given 10 passes through a moulding machine, using 80% of regrind mixed with 20% of virgin resin and 10 successive passes with 100% of regrind. In any case, one must remember that no regrind should be used which has had severe degradation such as splay or burning.

The pyramid illustrates the actual number of passes through a machine for any given amount of polymer from a blend of 80% regrind and 20% virgin material.

To illustrate, in the 10th pass, 14% of the feed has been through the machine 9 times; 3%, 8 times; 4%, 7 times, etc.

As standard practice for parts which require close control of tolerances, we normally recommend in the order of 20% of regrind.

Pass through machine	Regrind pyramid:	
	80% regrind / 20% virgin	
	Feed composition, %	
0 Virgin	100(0)	
2	80(1)/20(0)	
3	64(2)/16(1)/20(0)	
4	51(3)/13(2)/16(1)/20(0)	
5	41(4)/10(3)/13(2)/16(1)/20(0)	
6	33(5)/8(4)/10(3)/13(2)/16(1)/20(0)	
7	26(6)/6(5)/8(4)/11(3)/13(2)/16(1)/20(0)	
8	21(7)/5(6)/6(5)/9(4)/10(3)/13(2)/16(1)/20(0)	
9	17(8)/4(7)/5(6)/7(5)/8(4)/10(3)/13(2)/16(1)/20(0)	
0	14(9)/3(8)/4(7)/6(6)/6(5)/8(4)/10(3)/13(2)/16(1)/20(0)	

Effect on mechanical properties

Table 7.01 shows the results of a 10 pass regrind study which has been run using either 100% or 50% regrind with DELRIN® 500. A 10 pass 50% addition regrind study is equivalent to a moulder continuously regrinding 50% of the shot weight. Excellent retention of mechanical properties is observed in these conditions.

Table 7.01 Effect of number of passes through the moulding machine on selected physical properties of DELRIN® 500

No. of pass Effect on properties	10 times 100%	10 times 50%
Melt flow rate	increase less than 10%	increase less than 2%
Tensile strength at yield	no variation	no variation
Notched Charpy impact strength	decrease by 20%	decrease by 2%

Colouring

DELRIN® is available in a range of standard and custom colours.

When moulding natural DELRIN® with a colouring system from a manufacturer other than DuPont, the following should be noted:

- The pigment or masterbatch manufacturer's safe handling procedures must be applied.
- Small scale tests should be run initially to check melt stability (see page 27, foaming test), as some acidic, basic or metallic pigments will decompose DELRIN®.
- Different colouring systems (even those giving the same colour) could cause different shrinkage's, as can be seen from Fig. 6.04. Part dimensions should be checked in the small scale tests.
- Flow along injection unit screws is laminar and colour dispersion could be unsatisfactory. A proper mixing head should be used (see page 10).
- Total pigment loading should be as low as possible to maintain resin properties.

Disposal

Waste disposal must be in accordance with all applicable regulations. Preferred options for disposal are:

1. recycling,
2. incineration with energy recovery, and
3. landfill.

Recycling of sprue and runners is best done directly at the moulding machine (see Reground resin above). Mechanical recycling of post-consumer parts is rarely attractive. Since resin stability and mechanical prop-

erties can be severely affected by contamination, the separation and cleaning logistics become complicated and expensive. Chemical recycling is technically possible, but again it is presently limited by waste collection and separation.

The high fuel value of acetal resins makes option (2) very desirable for material that cannot be recycled. However, parts or regrind of resins containing TEFLON® (such as DELRIN® 500AF) should not be incinerated. For recyclability of packaging waste, see page 3.

8. Troubleshooting guide

In addition to the following list of problems and remedies, a more in depth computerised troubles shooting guide is available in DuPont's Computer Aided Moulding Diagnostic Optimisation (CAMDO) for DELRIN®. Three typical examples are shown at the end of this Section. For more information, contact your DuPont representative.

Problem	Suggested remedies (listed in order of convenience)
Dimensional problems	
Shot-to-shot dimensional variations	<ul style="list-style-type: none"> • Increase injection hold pressure • Maintain uniform pad (cushion) • Repair leaking back flow valve if pad cannot be maintained • Increase Hold (Pressure) Time • Increase gate thickness and/or location • Maintain uniform cycle • Eliminate unmelted particles (see below) • Use larger machine or screw designed for DELRIN®
Warpage	<ul style="list-style-type: none"> • Balance mould temperature • Locate gate in thickest area • Increase Hold (Pressure) Time • Increase gate thickness and/or location • Round sharp corner • Clean water channels in mould; improve mould cooling system • Improve part design (e. g. avoid bottlenecks in melt flow) • Change or add ejector pin locations
Ejection problems	
Parts sticking in mould	<ul style="list-style-type: none"> • Increase Hold (Pressure) Time • Correct mould defects (undercuts) • Change or add ejector pin locations • Decrease hold pressure • Decrease injection fill rate • Increase cycle (possibly only temporarily) • Use mould release temporarily
Sprue sticking	<ul style="list-style-type: none"> • Remove burrs on sprue • Correct alignment between sprue and nozzle • Radius sharp corners where the sprue meets the runner (or the part) • Increase Hold (Pressure) Time • Increase nozzle temperature • Increase mould cooling time • Use nozzle orifice smaller than sprue bushing • Improve sprue puller • Increase taper of sprue • Use mould release temporarily
Filling problems	
Short shots	<ul style="list-style-type: none"> • Maintain uniform pad • Repair leaking back flow valve if pad cannot be maintained • Increase injection fill pressure • Increase injection fill rate • Increase melt temperature • Increase mould temperature • Enlarge vents • Change vent location • Increase overall cycle • Use screw designed for DELRIN® • Use larger machine or injection unit
Note: Minimize nozzle length when moulding at or near limit of injection pressure capacity of moulding equipment. This will be particularly true for DELRIN®100 type resins having high melt viscosity.	
Voids in parts	<ul style="list-style-type: none"> • Increase hold pressure • Increase Hold (Pressure) Time • Locate gate in thickest area • Decrease injection fill rate • Decrease melt temperature; improve melt uniformity • Repair leaking back flow valve if pad cannot be maintained • Enlarge vents • Improve gate thickness or location • Eliminate any restrictions in runner or nozzle

Problem	Suggested remedies (listed in order of convenience)	(continued)
Weak weld lines	<ul style="list-style-type: none"> • Increase hold pressure • Adjust injection fill rate (around 1 s per mm of part thickness) • Increase melt temperature, but avoid excessive temperature • Enlarge vents • Increase mould temperature • Avoid mould release spray • Change vent or gate location • Use larger machine or injection unit 	
Melt quality problems		
Mould deposit	<ul style="list-style-type: none"> • Decrease injection fill rate • Decrease melt temperature • Avoid resin contamination • Correct hold-up spots in cylinder, screw, nozzle assembly • Increase gate size, flare gate • Enlarge vents • Change vent location • Use hopper drier to improve the resin's thermal stability in extreme cases 	
Odour	<ul style="list-style-type: none"> • Observe melt appearance (gassing) and measure melt temperature • Reduce cylinder temperatures if melt temperature is high • Avoid resin contamination • Reduce overall cycle to decrease holdup time • Correct holdup spots in cylinder, adaptor, nozzle, screw tip, and check valve assembly • Use smaller injection unit 	
Unmelted particles	<ul style="list-style-type: none"> • Increase cylinder temperatures • Increase back pressure • Reduce screw rpm • Use hopper drier to preheat resin • Increase overall cycle • Use screw designed for DELRIN® • Use larger machine or injection unit 	
Screw deposit	<ul style="list-style-type: none"> • Lessen severity of screw (esp. for DELRIN® 100 flow grades) – within recommendations • Avoid overcooling the feed throat • Check % of feed/transition/metering – within recommendations 	
Surface problems		
Black spots or brown streaks	<ul style="list-style-type: none"> • Decrease residence time in injection unit (smaller screw) • Avoid resin contamination • Correct holdup spots in cylinder, screw, nozzle assembly • Check hopper cooling (80–90°C) 	
Blush, frost, and folds	<ul style="list-style-type: none"> • Decrease injection fill rate • Increase mould temperature • Change gate location 	
Gate smear	<ul style="list-style-type: none"> • Decrease injection fill rate • Flare gate • Increase gate size • Change gate location 	
Jetting	<ul style="list-style-type: none"> • Increase or decrease injection fill rate • Increase gate size, flare gate • Increase mould temperature • Change gate location 	
Pits, orange peel, wrinkles	<ul style="list-style-type: none"> • Increase hold pressure • Increase injection fill rate • Increase Hold (Pressure) Time • Increase mould temperature • Increase melt temperature • Enlarge vents • Increase gate size 	

Problem	Suggested remedies (listed in order of convenience)	(continued)
Sink marks	<ul style="list-style-type: none"> • Repair leaking back flow valve if pad cannot be maintained • Increase hold pressure • Increase Hold (Pressure) Time • Increase gate size • Change gate location • Decrease melt temperature if it is too high 	
Splay	<ul style="list-style-type: none"> • Decrease melt temperature if it is too high • Avoid resin contamination • Decrease injection fill rate • Correct holdup spots in cylinder screw, nozzle assembly • Increase size of small gate 	

Simulated computer screens from CAMDO

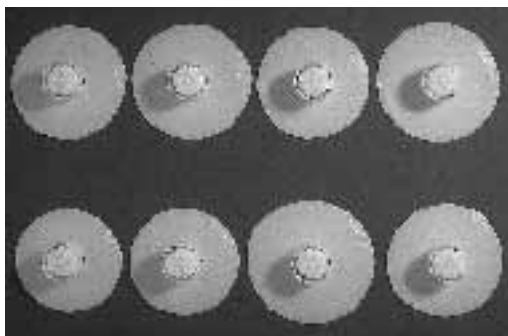

Example 1

SHORT SHOTS

DESCRIPTION: 2 cases:

1. consistent: parts are unfilled in the same way each shot.
2. inconsistent: vary from shot to shot.

CAUSES:

1. consistent: too low injection fill pressure/filling speed, low mould temperature, vents blocked.

2. inconsistent: inhomogeneous melt, improper screw design, leaking back flow valve.

SHORT REMEDIES:

1. consistent:
 - control fill pressure setting and evaluate effect of higher fill pressure/higher fill speed;
 - increase mould temperature to ease filling/ increase number of gate;
 - enlarge – move or clean vents.
2. inconsistent:
 - if short shots at start-up, keep the machine stopped for 5 min and inject; if parts are full, change cylinder temperature settings, raise back pressure, lower screw rotation speed. Be careful as you may face in production unmelt leading too low mechanical performances, you will need high compression screw. Consult your DuPont representative;
 - maintain uniform pad otherwise leaking BFV should be repaired.

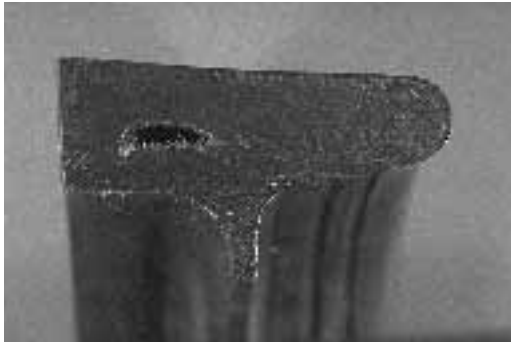

Example 2

VOIDS IN PARTS

DESCRIPTION:

Voids located in thickest section of the part.

CAUSES:

the specific volume decrease of the material during crystallisation was not compensated for.

SHORT REMEDIES:

- Check hold (pressure) time efficiency via weight curve – you may have to increase gate size, sub-runner size, nozzle and runner dimensions (see molding guide).
- Part not gated in thickest part → change gate location.
- If part thickness is inconsistent – use a flow leader to “feed” thicker sections of part.
- Increase hold pressure.
- Check pad; if inconsistent check back flow valve.

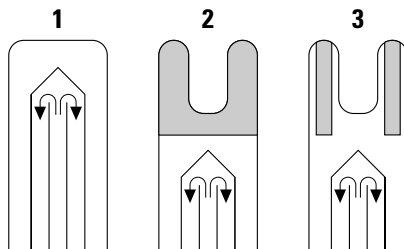
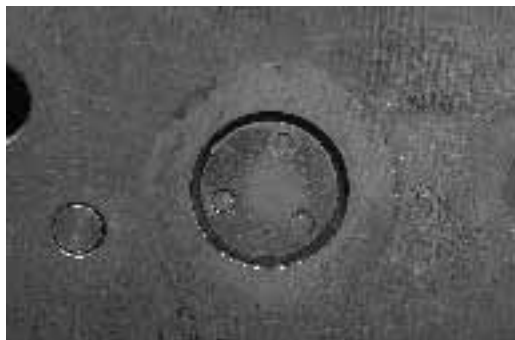

1. bubbler pipe in stainless steel
2. top of core in BeCu
3. inserted copper pins

Example 3

MOULD DEPOSIT

DESCRIPTION: 2 kinds of deposits:

1. White in cavities, deposit P.
2. Translucent or colored and on pins or hot spots, deposit S.

CAUSES:

1. Deposit P: thermal degradation (temperature or shear).
2. Deposit S: too high mould temperature.

SHORT REMEDIES:

1. Deposit P:
 - Run foaming test, if degradation detected, check temperature settings of injection unit (and nozzle below 190°C) and/or material stability (specially with colouring systems other than DuPont concentrates. In extreme conditions, drying the resin at 80°C for 2 hours may reduce mold deposit).
 - Decrease injection speed, increase or flare gate... to decrease shear if deposit around gate.
2. Deposit S:
 - Improve thermal homogeneity of the cavities/pins (should be set below 120°C).
 - Use DELRIN® P.

9. Index

	Page		Page
A			
Air Shots	3	Dimensional Stability	1, 16, 33-36
Air Trapping	16	Drool	3, 12, 20, 26-27
Annealing	33, 36, 37	Drying	32, 39, 44
B			
Back Flow Valve	9-11, 41, 43, 43-44	E	
Back Pressure	13, 27, 32, 42-43	Ejection	1, 3, 21-22, 28, 31, 41
Blowback	3, 25	Elongation	2, 8, 31, 36
Brown Streaks	12, 42	Environmental Dimensional Change	37
Burning	21	F	
C			
Camdo	1, 11, 28, 41, 43	Fill Rate	28, 41-43
Cavity Pressure	32	Flash	21, 29
Check Ring	11-12	Flow	1, 5, 7-12, 15-16, 18-19, 21, 23, 25-26, 28-30, 32-35, 40-44
Clamping Force	30	Formaldehyde	1, 2, 3, 23
Colouring	10, 13, 39-41, 46	G	
Compositions	1, 2, 35, 39-40	Gassing	12, 42
Compression Ratio	10	Gate Design	16-18, 23, 29
Contamination	10, 11, 13, 25, 27, 31, 36, 40-43	Gate Freeze Time	35
Corrosion	12, 21, 27-28	Gate Location	16, 42, 43-44
Crystallinity	1, 2, 5, 33-34	Gate Size	42-44
Cushion	30, 41	Gate Smear	16, 28, 42
Cycle	1, 2, 6, 9-11, 13, 20, 22-23, 26-28, 30-32, 40-42	Gates	7, 10, 15-18, 21
Cycle Estimation	28	Gloss	28
Cylinder Temperature Control	11	H	
D			
Decomposition	1, 2, 3, 25	Handling Precautions	25
Degradation	9-12, 21, 26, 30, 44	Heat of Fusion	7
DELRIN® 100	1, 2, 10, 15, 23, 27, 30, 32-33, 37, 42	Hold-up Areas	2
DELRIN® 100P	2, 30	Hold-up Time	9, 26
DELRIN® 100ST	2, 26-27, 30, 32-33, 39	I	
DELRIN® 100T	2, 30	ISO	30, 32
DELRIN® 107	2	Injection Pressure	29, 34, 41
DELRIN® 111P	2, 32	Injection Rate	28
DELRIN® 127UV	2	Insert Moulding	36
DELRIN® 500	1, 6-8, 10, 27, 29-30, 32-36, 40	J	
DELRIN® 500AF	2, 33, 35, 40	Jetting	16, 28, 42
DELRIN® 500CL	2, 33	L	
DELRIN® 500P	1, 30, 33-34	Lubricants	1, 2, 33
DELRIN® 500T	2, 26, 30, 32-33, 39	M	
DELRIN® 507	1	Material Handling	39
DELRIN® 511P	1, 30, 32	Melt Output	26
DELRIN® 527UV	1	Melt Temperature	8, 9, 15, 26, 27, 32, 33, 39, 41-43
DELRIN® 570	2, 27, 33, 35	Melt Viscosity	1, 5, 7, 8, 15, 41
DELRIN® 577	33	Mould Deposit	9, 13, 19, 21, 39, 42
DELRIN® 900	27, 32		
DELRIN® 900P	1, 30		
DELRIN® 911P	27, 30, 32		

	Page		Page
M			
Mould Design	15, 29	Screw Design	10, 13, 27, 31, 41-43
Moulded-in Stresses	29, 36	Screw Forward Time	28
Mould Maintenance	15, 21, 23, 30	Screw Retraction Time	11, 28, 30-31
Mould Open Time	28, 31	Screw Rotation	10, 26, 27, 30-31, 43
Mould Shrinkage	15, 22, 27, 30-31, 33-36	Screw Rotation Speed	10, 26-27, 30-31, 43
Mould Temperature	22-23, 27, 29, 31-36, 41-44	Shutdown	25
N			
Non-return Valve	11-12	Sink marks	5, 16, 23, 30, 34-35, 43
Nozzle	2, 3, 9, 11-13, 16, 19, 25-26, 29, 31, 38, 41-44	Snake Flow Mould	15
O			
Odour	3, 21, 25, 42	Splay	9, 19, 21, 32, 40, 43
Open Nozzle	12	Start-up	2, 25, 43
Optimum Productivity	10, 25, 31	T	
P			
Pigments	10, 11, 33, 35-36, 40	Thermal Stability	9, 39, 42
Packaging	3, 40	Tolerances	11, 33, 36-38
Part Weight	29-30	Toughness	1, 2, 8, 10, 23, 28-29, 35, 39
Post-Moulding Shrinkage	34-38	Troubleshooting	21, 41
Projected Area	30	U	
Purging	25	Undercuts	15, 22, 41
R			
Recycling	3, 40	Unmelted Particles	10, 27, 31, 41, 42
Reground Resin	39-40	V	
Reverse Taper Nozzle	12	Venting	3, 16, 21-23, 31
Runnerless Moulds	15, 20	Voids	5, 7, 30-31, 34-35, 41, 44
Runners	7, 9, 15-16, 18-21, 25-26, 29, 31, 39-40	W	
Runners, Balanced	18-20	Warping	10
		Water Absorption	39
		Weld Line	16, 21, 23, 31, 42

Processing data for DELRIN® resins

Processing data for DELRIN®

Grade POM – H	Remarks	Solid density g/cm ³	Melt density at 0 MPa g/cm ³	Melt temp. Rec. °C±5°C	Cavity Surface temp. Rec. °C±10°C	Screw tan. speed m/s	Flow front speed B-M-E	Hold pressure REC. MPa	back pressure MPa	Hold pressure time Δ mm s/mm	Max hold-up time min	Shrinkage estimated ±0,2% paral. trasy. %	Max. process moisture %	Dessiccant dryer Drying Temp. max. °C	Rec. drying Time h
100	HV	1,42	1,16	215	90	0,20	M	90-110	<10	8	30	2,1	0,2	80	No
100P	HV	1,42	1,16	215	90	0,20	M	90-110	<10	8	30	2,1	0,2	80	No
111P	HV enhanced crystallisation	1,42	1,16	215	90	0,20	M	90-110	<10	7,5	30	2,0	0,2	80	No
500	MV	1,42	1,16	215	90	0,30	M	75-100	<5	8	30	2,1	0,2	80	No
500P	MV	1,42	1,16	215	90	0,30	M	75-100	<5	8	30	2,1	0,2	80	No
511P	MV enhanced crystallisation	1,42	1,16	215	90	0,30	M	75-110	<5	7	30	1,9	0,2	80	No
900P	LV	1,42	1,16	215	90	0,30	M	75-100	<5	8	30	2,1	0,2	80	No
911P	LV enhanced crystallisation	1,42	1,16	215	90	0,30	M	75-100	<5	7	30	1,9	0,2	80	No
107	HV UV	1,42	1,16	215	90	0,20	M	90-110	<10	8	30	2,1	0,2	80	No
127UV	HV UV	1,42	1,16	215	90	0,20	M	90-110	<10	8	30	2,1	0,2	80	No
507	MV UV	1,42	1,16	215	90	0,30	M	75-100	<5	8	30	2,1	0,2	80	No
527UV	MV UV	1,42	1,16	215	90	0,30	M	75-100	<5	8	30	2,1	0,2	80	No
927UV	LV UV	1,42	1,16	215	90	0,30	M	75-100	<5	8	30	2,1	0,2	80	No
100T	HV toughened	1,37	1,14	205	50	0,15	M	60-80	<10	8	30	1,8	0,06	80	4
100ST	HV super-toughened	1,34	1,14	205	50	0,15	M	60-80	<10	8	15	1,3	0,06	80	4
500T	MV toughened	1,39	1,15	205	50	0,15	M	60-80	<5	8	25	1,8	0,06	80	4
500AF	MV 20% TEFLON® fibres	1,54	1,29	215	90	0,30	M	75-100	<5	8	30	2,1	0,2	80	No
500CL	MV chemically lubricated	1,42	1,16	215	90	0,30	M	75-100	<10	8	30	1,9	0,2	80	No
570 NC000	MV 20% glass fibres	1,56	1,30	215	90	0,20	M	75-100	<5	8	30	1,2	0,2	80	No
577 BK000	MV 20% GF + UV	1,56	1,30	215	90	0,20	M	75-100	<5	8	30	1,2	0,2	80	No
525GR	MV 25% glass	1,58	1,33	215	90	0,20	M	75-100	<5	8	30	1,0	0,2	80	No
DE7031	Extrusion grade "p"	1,42	1,16	215	90	0,20	M	90-110	<5	8	30	2,0	0,2	80	No

HV = High viscosity
MV = Medium visc.
LV = Low viscosity

For further information on Engineering Polymers contact :

Internet location : <http://plastics.dupont.com>

Belgique / België

Du Pont de Nemours (Belgium)
Antoon Spinostraat 6
B-2800 Mechelen
Tel. (15) 44 14 11
Telex 22 554
Telefax (15) 44 14 09

Bulgaria

Serviced by Biesterfeld Interowa GmbH & Co. KG.
See under Österreich.

Česká Republika a Slovenská Republika

Du Pont CZ, s.r.o.
Pekarska 14/268
CZ-155 00 Praha 5 – Jinonice
Tel. (2) 57 41 41 11
Telefax (2) 57 41 41 50-51

Danmark

Du Pont Danmark ApS
Skjøtevej 26
P.O. Box 3000
DK-2770 Kastrup
Tel. 32 47 98 00
Telefax 32 47 98 05

Deutschland

Du Pont de Nemours (Deutschland) GmbH
DuPont Straße 1
D-61343 Bad Homburg
Tel. (06172) 87 0
Telex 410 676 DPD D
Telefax (06172) 87 27 01

Egypt

Du Pont Products S.A.
Bldg no. 6, Land #7, Block 1
New Maadi
ET-Cairo
Tel. (00202) 754 65 80
Telefax (00202) 516 87 81

España

Du Pont Ibérica S.A.
Edificio L'Illa
Avda. Diagonal 561
E-08029 Barcelona
Tel. (3) 227 60 00
Telefax (3) 227 62 00

France

Du Pont de Nemours (France) S.A.
137, rue de l'Université
F-75334 Paris Cedex 07
Tel. 01 45 50 65 50
Telex 206 772 dupon
Telefax 01 47 53 09 67

Hellas

Ravago Plastics Hellas ABEE
8, Zakythou Str.
GR-15232 Halandri
Tel. (01) 681 93 60
Telefax (01) 681 06 36

Israël

Gadot
Chemical Terminals (1985) Ltd.
22, Shalom Aleichem Street
IL-633 43 Tel Aviv
Tel. (3) 528 62 62
Telex 33 744 GADOT IL
Telefax (3) 528 21 17

Italia

Du Pont de Nemours Italiana S.r.L.
Via Volta, 16
I-20093 Cologno Monzese
Tel. (02) 25 30 21
Telefax (02) 25 30 23 06

Magyarország

Serviced by Biesterfeld Interowa GmbH & Co. KG.
See under Österreich.

Maroc

Deborel Maroc S.A.
40, boulevard d'Anfa – 10°
MA-Casablanca
Tel. (2) 27 48 75
Telefax (2) 26 54 34

Norge

Distrupol Nordic
Niels Leuchsvei 99
N-1343 Eiksmarka
Tel. 67 16 69 10
Telefax 67 14 02 20

Österreich

Biesterfeld Interowa GmbH & Co. KG
Bräuhäusgasse 3-5
P.O. Box 19
AT-1051 Wien
Tel. (01) 512 35 71-0
Fax (01) 512 35 71-31
e-mail: info@interowa.at
internet: www.interowa.at

Polska

Du Pont Poland Sp. z o.o.
ul. Powazkowska 44C
PL-01-797 Warsaw
Tel. +48 22 320 0900
Telefax +48 22 320 0910

Portugal

ACENYL
Rua do Campo Alegre, 672 – 1°
P-4100 Porto
Tel. (2) 69 24 25/69 26 64
Telex 23 136 MACOL
Telefax (2) 600 02 07

Romania

Serviced by Biesterfeld Interowa GmbH & Co. KG.
See under Österreich.

Russia

E. I. du Pont de Nemours & Co. Inc.
Representative Office
B. Palashevsky Pereulok 13/2
SU-103 104 Moskva
Tel. (095) 797 22 00
Telex 413 778 DUMOS SU
Telefax (095) 797 22 01

Schweiz / Suisse / Svizzera

Dolder AG
Immengasse 9
Postfach 14695
CH-4004 Basel
Tel. (061) 326 66 00
Telefax (061) 322 47 81
Internet: www.dolder.com

Slovenija

Serviced by Biesterfeld Interowa GmbH & Co. KG.
See under Österreich.

Suomi / Finland

Du Pont Suomi Oy
Box 62
FIN-02131 Espoo
Tel. (9) 72 56 61 00
Telefax (9) 72 56 61 66

Sverige

Serviced by Du Pont Danmark ApS.
See under Danmark.

Türkiye

Du Pont Products S.A.
Turkish Branch Office
Sakir Kesebir cad. Plaza 4
No 36/7, Balmumcu
TR-80700 Istanbul
Tel. (212) 275 33 82
Telex 26541 DPIS TR
Telefax (212) 211 66 38

Ukraine

Du Pont de Nemours International S.A.
Representative Office
3, Glazunova Street
Kyiv 252042
Tel. (044) 294 96 33/269 13 02
Telefax (044) 269 11 81

United Kingdom

Du Pont (U.K.) Limited
Maylands Avenue
GB-Hemel Hempstead
Herts. HP2 7DP
Tel. (01442) 34 65 00
Telefax (01442) 24 94 63

Argentina

Du Pont Argentina S.A.
Avda. Mitre y Calle 5
(1884) Berazategui-Bs.As.
Tel. +54-11-4229-3468
Telefax +54-11-4229-3117

Brasil

Du Pont do Brasil S.A.
Al. Itapecuru, 506 Alphaville
06454-080 Barueri-São Paulo
Tel. (5511) 7266 8229

Asia Pacific

Du Pont Kabushiki Kaisha
Arco Tower
8-1, Shimomoguro 1-chome
Meguro-ku, Tokyo 153-0064
Tel. (03) 5434-6935
Telefax (03) 5434-6965

South Africa

Plastamid (Pty) Ltd.
43 Coleman Street
P.O. Box 59
Elsies River 7480
Cape Town
Tel. (21) 592 12 00
Telefax (21) 592 14 09

USA

DuPont Engineering Polymers
Barley Mill Plaza, Building #22
P.O. Box 80022
Wilmington, Delaware 19880
Tel. (302) 999 45 92
Telefax (302) 892 07 37

Requests for further information from countries not listed above should be sent to:

Du Pont de Nemours International S.A.

2, chemin du Pavillon
CH-1218 Le Grand-Saconnex/Geneva
Tel. (022) 717 51 11
Telex 415 777 DUP CH
Telefax (022) 717 52 00

The information provided in this documentation corresponds to our knowledge on the subject at the date of its publication. This information may be subject to revision as new knowledge and experience becomes available. The data provided fall within the normal range of product properties and relate only to the specific material designated; these data may not be valid for such material used in combination with any other materials or additives or in any process, unless expressly indicated otherwise. The data provided should not be used to establish specification limits nor used alone as the basis of design; they are not intended to substitute for any testing you may need to conduct to determine for yourself the suitability of a specific material for your particular purposes. Since DuPont cannot anticipate all variations in actual end-use conditions DuPont makes no warranties and assumes no liability in connection with any use of this information. Nothing in this publication is to be considered as a license to operate under or a recommendation to infringe any patent rights.

Caution: Do not use this product in medical applications involving permanent implantation in the human body. For other medical applications see "DuPont Medical Caution Statement".