

TECHNICAL MANUAL

**ELECTRICAL POWER
APPLICATIONS FOR
INFORMATION TECHNOLOGY (IT)
EQUIPMENT INSTALLATION AND
INSPECTION AT COMMAND,
CONTROL, COMMUNICATIONS,
COMPUTER, INTELLIGENCE,
SURVEILLANCE, AND
RECONNAISSANCE (C4ISR)
FACILITIES**

APPROVED FOR PUBLIC RELEASE: DISTRIBUTION IS UNLIMITED

HEADQUARTERS, DEPARTMENT OF THE ARMY

28 APRIL 2006

REPRODUCTION AUTHORIZATION/RESTRICTIONS

This manual has been prepared by or for the Government and, except to the extent indicated below, is public property and not subject to copyright.

Reprint or republication of this manual should include a credit substantially as follows: “Department of the Army TM 5-689, Electrical Power Applications for Information Technology (IT) Equipment Installation and Inspection at Command, Control, Communications, Computer, Intelligence, Surveillance, and Reconnaissance (C4ISR) Facilities, 28 April 2006.”

Appendix B reprinted with permission from Information Technology Industry Council (ITI) “*ITI (CBEMA) Curve*”, copyright © 1999 by ITI. ITI disclaims any responsibility of liability resulting from the placement and use in the described manner.

APPROVED FOR PUBLIC RELEASE; DISTRIBUTION IS UNLIMITED

Electrical Power Applications for Information Technology (IT) Equipment Installation and Inspection at Command, Control, Communications, Computer, Intelligence, Surveillance, and Reconnaissance (C4ISR) Facilities

CONTENTS

		<i>Paragraph</i>	<i>Page</i>
CHAPTER 1.	INTRODUCTION		
	Purpose	1-1	1-1
	Scope	1-2	1-1
	References	1-3	1-1
CHAPTER 2.	FACILITY POWER SYSTEM		
	Dependable power system requirements	2-1	2-1
	Commercial (utility) power	2-2	2-3
	Power line phenomena	2-3	2-4
	Power quality requirements	2-4	2-6
	Power quality parameters	2-5	2-7
	Detection of power line anomalies	2-6	2-8
CHAPTER 3.	POWER CONDITIONING		
	Information technology equipment power requirements	3-1	3-1
	Power line disturbances	3-2	3-2
	Acceptable limits for ac power	3-3	3-4
	IT protective equipment	3-4	3-5
	Power distribution systems	3-5	3-15
CHAPTER 4.	GROUNDING		
	Purpose of grounding	4-1	4-1
	National electrical code (NEC) requirements for grounding	4-2	4-1
	System configurations	4-3	4-4
	Ground configurations	4-4	4-9
	Grounding for fault protection	4-5	4-10
	IT equipment grounding	4-6	4-16
CHAPTER 5.	HARMONICS		
	Harmonics defined	5-1	5-1
	Harmonic sources	5-2	5-1
	Harmonic technical history	5-3	5-2

	<i>Paragraph</i>	<i>Page</i>
Resonance	5-4	5-3
Electrical loads	5-5	5-4
Neutral currents	5-6	5-6
Derating power equipment	5-7	5-6
Generator control problems	5-8	5-7
UPS output harmonic distortion	5-9	5-8
Solution of harmonic problems	5-10	5-8
Measurement of non-sinusoidal currents and voltages	5-11	5-11
Conclusions	5-12	5-12
 CHAPTER 6.		
STANDBY POWER		
Introduction	6-1	6-1
Codes and standards	6-2	6-3
Off-line/on-line IT systems standby power requirements	6-3	6-3
Diesel generator standby systems	6-4	6-5
Battery standby systems	6-5	6-8
Transfer switches for standby systems	6-6	6-20
Grounding standby power systems	6-7	6-30
 CHAPTER 7.		
LIGHTNING		
Lightning effects on power systems	7-1	7-1
Principals of protection	7-2	7-4
Lightning protection systems	7-3	7-5
 CHAPTER 8.		
INSTALLATION		
Objectives of an information technology equipment facility	8-1	8-1
Contract bidding	8-2	8-1
Inspection requirements	8-3	8-2
Ground system installation inspections	8-4	8-3
Neutral junction installation inspections	8-5	8-4
Safety ground installation inspections	8-6	8-4
Inspecting for unbalanced loads	8-7	8-6
Utility power system installation inspections	8-8	8-6
RFI inspections	8-9	8-7
ESD inspection	8-10	8-9
IT system environment inspections	8-11	8-10
Pre-site inspection	8-12	8-12
Pre-inspection for electrical systems	8-13	8-12
IT equipment room inspection	8-14	8-13
Air-conditioning system inspection	8-15	8-13
Lighting system inspection	8-16	8-14
Fire safety inspection	8-17	8-14
Total evaluation	8-18	8-14
 CHAPTER 9.		
MAINTENANCE		
Objective	9-1	9-1
Maintenance program	9-2	9-2
Maintenance data file	9-3	9-4
Personnel qualifications	9-4	9-5

	<i>Paragraph</i>	<i>Page</i>
Dedicated maintenance equipment	9-5	9-6
Renewal parts	9-6	9-7
Continuous inspection program	9-7	9-8
Maintenance schedule	9-8	9-8
Maintenance tests	9-9	9-9
Safety	9-10	9-10
Electrical equipment fires	9-11	9-12
Equipment diagrams	9-12	9-12
Test forms	9-13	9-13
APPENDIX A. REFERENCES		A-1
APPENDIX B. ITI (CBEMA) CURVE APPLICATION NOTE		B-1
GLOSSARY		G-1

LIST OF TABLES

<i>Table</i>	<i>Title</i>	<i>Page</i>
Table 4-1	Summary of the effects of shock	4-11
Table 5-1	Voltage distortion limits for medium and high voltage power systems	5-2
Table 6-1	Typical range of input power quality and load parameters of major computer manufacturers	6-2
Table 6-2	Comparison of cells required for NICAD and lead acid batteries	6-19

LIST OF FIGURES

<i>Figure</i>	<i>Title</i>	<i>Page</i>
Figure 4-1	Minimum grounding requirements for ac powered isolated system	4-5
Figure 4-2	Minimum grounding requirements for battery powered isolation system	4-6
Figure 4-3	Clustered system	4-6
Figure 4-4	Basic grounding of a clustered system	4-7
Figure 4-5	Central-with-extensions system	4-9
Figure 4-6	Single phase 115/230 Vac power system ground connections	4-13
Figure 4-7	Three phase 120/208 Vac power system ground connections	4-13
Figure 4-8	Properly wired ac distribution circuits for minimum ground noise	4-14
Figure 4-9	Noise problems resulting from improper wiring	4-15
Figure 5-1	Tuned passive filter	5-9
Figure 5-2	Impedance poles and zeros of tuned passive filter	5-10
Figure 5-3	Tuned passive filter with static Var control	5-10
Figure 5-4	Active load current compensation	5-11

CHAPTER 1

INTRODUCTION

1-1. Purpose

The purpose of this manual is to familiarize qualified personnel with problem areas of supplying electrical power to information technology (IT) equipment systems. These systems typically consist of a wide variety of computer and support equipment as found on a raised computer floor (e.g., network computers, server farms, communication equipment, etc.). Special emphasis is placed on areas most often overlooked or misunderstood by experienced designers and personnel responsible for maintaining an outflow of quality data from an IT equipment installation. IT systems are highly reliable, but will on occasion malfunction and because of their complexity will require the services of highly skilled personnel to correct and maintain the systems. This manual covers many inter-related aspects of an IT (sometimes referred to as an automated data processing (ADP)) installation in regard to the electrical and life-safety systems. This manual will review the systems found in the typical data center, and is not intended to provide the detailed level of understanding where arithmetic and other more advanced mathematics are required to describe or explain a given function.

1-2. Scope

This manual is limited in scope in that it is not intended to be a course in the design of IT electrical systems or related components. The engineering skills needed to design IT systems are abilities acquired through the process of formal education and actual field experience. The area of field experience will be stressed in this manual and the subjects focused upon will be those areas that are frequently the least understood. This manual will be useful to the power-oriented engineer with limited commercial building experience and personnel responsible for the electrical design, inspection, installation, and maintenance supervision of electrical power distribution systems supplying IT systems. This manual is not intended as a replacement for the engineering text furnished as part of IT system components, but rather, should be used to supplement and better evaluate established design practices. While the fundamental objective of any IT system is the processing of input data, the output data can be greatly altered and influenced by the quality of power supplying the IT system. In spite of the wide variation of systems in use, all IT systems respond adversely in some degree to the quality of the basic power sources available.

1-3. References

Design, installation, and maintenance requirements should follow the latest version of applicable codes and standards from recognized industry and commercial groups and committees. Appendix A contains a complete listing of references used in this manual.

CHAPTER 2

FACILITY POWER SYSTEM

2-1. Dependable power system requirements

Commercial power companies attempt to provide continuous, trouble-free, dependable service. The computer and other sophisticated electronic devices have become of great concern throughout industry as users become more dependent on continuous up-time and trouble-free operation of their systems. Better knowledge of ac power and the problems that introduce faulty conditions would prevent unnecessary downtime and costly repairs. Initial site preparation, proper installation procedures, and the use of proper power line conditioning devices can prevent many of these related problems.

a. Environmental conditions play a major part in insuring that computer systems operate at maximum efficiency. Proper temperature control becomes very important. Variations in temperature lead to component thermal shock, resulting in excessive downtime. High particulate counts in the atmosphere contaminate and cause problems. Corrosives have short- and long-term adverse effects. Vibration in heavy industrial areas must be observed and considered. Radio frequency interference (RFI) must be detected and prevented and so must electrostatic discharge (ESD).

b. Conductive contamination of computer room equipment by zinc whiskers can cause voltage or signal perturbations leading to machine errors or equipment shutdown. Zinc whiskers are microscopic zinc filaments that grow on the underside of electroplated floor tiles. They can grow on metal stringers or on the bottom or sides of floor tiles that have a zinc electroplated-passivation coating on the tile's sheet metal pan. As floor tiles are moved or disturbed, the zinc whiskers break off, become airborne, and make their way inside computer systems' equipment. The zinc whiskers become lodged in electronic components of logic cards and power supplies causing either a voltage or signal perturbation or short circuit. At this point the machine posts an error or shuts down. Inspection, cleaning and floor tile replacement can prevent or correct this problem. However, computer room floor tile manufacturers have identified this problem as no zinc electroplated floor tiles have been manufactured for several years.

c. The five most prevalent causes of computer and electronic problems are: (1) poor or improper grounding of equipment, (2) loose wiring connections, (3) improper computer room temperature and humidity control, (4) degraded power, and (5) systems mismatching.

d. Power line noise, poor regulation, and impulse transients can cause a host of problems when coupled into sensitive electrical and electronic circuits. Steps can be taken to reduce these problems by proper conditioning, grounding, and shielding. Yet, the weakest link in such circuitry may well be the power supply, since these impulse transients and the line noise may be coupled through it and superimposed on the signals. Low-level analog circuits are not unique in this respect. Digital instrumentation, computers, data processing equipment, recorders, etc., are all vulnerable.

e. The commercial utility specifications define limits for amplitude variations, frequency variations, and harmonic distortion for the power they furnish, but make no official mention of the fluctuations lasting from 1 microsecond to 30 milliseconds that occur during load switching, transformer tap switching, or phase compensation. Some utilities have, however, admitted that voltage variations to 300 percent, lasting up to 1 minute, may occur. Their position is understandable, considering that many of the fluctuations, impulse transients, and interruptions are not caused by their own equipment.

f. When the electric lights flicker, it means that a power line voltage fluctuation has occurred. It also means that the fluctuation lasted about half a second since the human eye cannot detect light intensity changes that occur at much faster rates. However, many of the fluctuations that appear on power lines last for only a few milliseconds or microseconds. Critical electronic circuits respond to these high-speed fluctuations, causing erratic and erroneous operation. In addition, subjecting circuit components to the cumulative stresses exerted by these impulse transients can cause intermittent changes or component breakdowns that may occur even at a time when line transients are not present. Therefore, it is vital to determine whether the power source is clean.

g. The power line is exposed to all the electrical noise generated by the appliances, tools, and machines that receive power from it, and this electrical noise is superimposed on the line voltage and coupled through the power step-down transformer. When this electrical noise passes through the transformer, it appears in the power supply. The electrical noise may cause the power supply to malfunction or may simply pass through it to appear in the electronic logic, control, or amplifier circuits. In either case, the electrical noise may cause a computer to make errors or may cause loss of mission.

h. Power line conductors also act as antennas and pick up radiated voltage from automobile ignition systems, high-power transmitters, fluorescent lamps, diathermy machines, and lightning. These voltages appear equally on each conductor of a pair, and consequently cannot be measured between them. The voltages do, however, appear between either lead and ground. While this voltage cannot be detected between the input leads, it is coupled through the distribution capacitances between the individual turns of the primary and secondary transformer winding and appears as normal mode noise across the secondary winding. Suppressing these line surges, dips, transients, and power fluctuations at their radiated voltage sources would be an impossible task. The only realistic approach to eliminating their effects is to isolate each critical equipment installation from these disturbances.

i. There are only six basic categories of power line problems - total loss of line power for extended periods, insufficient or excessive power line voltage, harmonic distortion, high frequency noise, impulse transients, and combinations of these.

(1) With a total loss of power, the equipment receives no power and does not operate.

(2) During insufficient or excessive voltage, many types of equipment malfunctions and even equipment damage can occur, but the condition can be detected by monitoring the power and voltage with an ac voltmeter.

(3) Harmonic distortion is detected using either an oscilloscope or a harmonic distortion analyzer.

(4) The remaining types of problems, noise and impulse transients, cannot be detected by either the human eye or an ordinary voltmeter, because neither the eye nor the basic meter can respond to the rate of change that occurs when these phenomena are present. Studies have concluded that these types of transient overvoltages cause almost 90 percent of soft and hard failure to computer systems through the power line. The ideal device for detecting either noise or impulse transients is a power line monitor, provided it has the proper characteristics and is correctly connected to the power circuit. However, even many expensive monitors do not give total true peak amplitudes, rendering it impossible to correlate the amplitude of an impulse and its relationship to the sinewave. The best power line monitors will record transients with amplitudes varying from a few hundred volts to several hundreds or thousands of volts which last for as little as 30 nanoseconds. Some record amplitude, frequency, and time. Some monitor only single-phase power lines and others accept and monitor three-phase inputs. Proper connections of the monitoring equipment are a must. An improperly connected monitor may totally ignore line voltage

abnormalities, and the power line may be erroneously eliminated as the culprit when critical measuring or IT equipment malfunctions. Measurement limits must also be set properly or much of the valuable data may be misinterpreted and ignored.

2-2. Commercial (utility) power

Electrical power generating plants are generally located in remote areas near some natural source of power such as water, oil, or coal. The electrical power must be delivered to where it is consumed via a transmission line. To minimize losses, power is transmitted at high voltage and low current. The generator output is three-phase, ac power normally at 18,000 to 22,000 volts. The voltage is then increased through step-up transformers to 69,000 to 500,000 volts. These high voltage transmission lines are then tapped off at substations, which step the voltage down and deliver three-phase ac power to the local lines at some intermediate voltage such as 13,800 volts. The final reduction to a nominal 480 volts or 208/120 volts usually occurs at a transformer located near or in the user's facility. This may also be derived from the incoming 480 volt power line with an additional step-down transformer.

a. Power is generated and transmitted in three-phase form for several reasons. Three-phase current produces a rotating field, which is useful in motor applications. Poly-phase motors are simpler to construct, are more efficient, and operate more smoothly, especially at larger horsepower ratings; i.e., 100 horsepower and above. Three-phase power also has less ripple when rectified, thus requiring less filtering. The three-phase, three-wire transmission system delivers 1.73 (square root of 3) times as much power as a two-wire, single-phase system. This results in a savings of 25 percent in the amount of copper required to transmit a given amount of power a fixed distance with a given line loss and fixed voltages between conductors.

b. North American utility companies attempt to maintain electrical power within the following tolerances.

(1) The nominal frequency of 60 hertz is maintained within ± 0.5 hertz. The frequency is generally within ± 0.2 hertz in the United States and Canada because of the grid integrity between the two countries and between areas within each country.

(2) Utilities attempt to provide voltage with no harmonic distortion; i.e., no frequency component other than the 60 hertz fundamental frequency. There will, however, inevitably be evidence of the 3rd, 5th, and 7th harmonics.

(3) Utilities also strive to limit noise spikes - generated either within or outside the service drop (from transformer to main service panel). Spikes (impulse transients) from lightning and switching operations will be present, however.

(4) "Normal" voltage root mean square (RMS) amplitudes are as follows.

(*a*) The 120 volts normal is permitted to drop to 111 volts at the utility feed (distribution transformer).

(*b*) From the utility an additional 3 percent voltage drop is allowed to the service entrance (meter).

(*c*) A 2 percent drop is considered acceptable from the service entrance to the equipment.

(d) The lowest allowable RMS value at the equipment is, therefore, 105 volts without brownouts.

2-3. Power line phenomena

There are six basic power line disturbances or anomalies.

a. A loss of voltage or a complete power outage can range from downed power lines to failed transformers, to tripped circuit breakers, etc. These power outages may last for a short one-half cycle of the 60 hertz sinewave (8.3 milliseconds) or for several hours. Most are no longer than a few seconds.

b. High or low voltages are a common occurrence and can be detected with a voltmeter or a voltage recorder. Causes may be power lines, distribution panels, and/or the wiring being too heavily loaded. In addition, being too close to the source of the power or too far from the source of power can cause large voltage fluctuations, as well as starting or stopping heavy motor loads, non-uniform loading of poly-phase transformers, or poor regulation. If an undervoltage condition continues for more than 0.5 cycle (8.3 milliseconds), but less than 1 minute, this is referred to as a sag. If an overvoltage condition continues for more than 0.5 cycles (8.3 milliseconds), but less than 1 minute, this is referred to as a swell. Longer than 1 minute they are referred to as an undervoltage or overvoltage.

c. Harmonic distortion occurs when the normal sinewave is mis-shaped as a result of harmonics (multiples of the primary frequency). When 60 hertz power is generated to non-linear loads, multiple harmonic frequencies are generated but normally only the odd harmonics have sufficient amplitude to be of concern. Generally, these harmonics can only be detected by specially designed equipment. Flat-topping of the sinewave, as seen on an oscilloscope, is the first indication of harmonic distortion. Under severe conditions, the sinewave can look extremely distorted. Causes may include overloading or improper loading of transformers, faulty regulation transformers, fluorescent or other electric-discharge lighting, and/or IT equipment.

d. Noise is normally detected as bad or faulty data and then investigated with an oscilloscope. Oscilloscopes are used to detect and analyze high frequency events or even to analyze the 60 hertz power sinewave. Noise is a low voltage, low current, high frequency signal riding on the 60 hertz sinewave and is characterized by having a repeatable frequency pattern, one that can be determined and analyzed. Generally it is electromagnetic interference (EMI) and is caused by having the power or data lines or the equipment too close to a source of EMI; a large motor or transformer for instance. Improper grounds or grounding can also be a cause. Noise can also be caused by RFI if a radio tower or transmitter is located nearby.

e. Transients or impulses are high voltage, high-current, fast bursts of energy riding on the 60 hertz sinewave. They also exhibit a non-repeatable frequency pattern even when resulting from the same repeated event. They exhibit extremely fast rise times (1 microsecond to peak) and last for less than 8.3 milliseconds, usually decaying to 50 percent of peak value in 1 millisecond or less. Because they have no repeatable frequency pattern and are random in occurrence, they are extremely difficult to detect. Power line analyzers must be used to detect the presence of transients although the first indication of their existence is usually data errors, computer crashes, and damaged circuitry. Microprocessor based equipment is very susceptible to damage from these anomalies. Transients occur whenever the current through any inductive load (motors, transformers, coils of any kind) is changed at a rapid rate. This rapid change in current is the result of switching actions, sudden power outages, and applications of power. Transients are also induced on power and data lines by nearby lightning strikes or having data lines too close to power lines that are being switched.

f. The most common anomaly is any combination of the above. While any of these problems can and do occur by themselves, the more general rule is for them to occur in combinations. Transients always accompany voltage outages. High or low voltages may result in noise when power supplies are put under the strain of having to work at input voltage levels outside their design limits.

g. Different anomalies have different effects on various types of equipment. Take, for example, the length of a power interruption. A wall clock or scanner may be unaffected for up to four cycles without power. Other equipment like card readers, symbol generators, and many computers cannot stand to be without power for even one-half cycle (8.3 milliseconds). The equipment that is the most susceptible to short interruptions will also be the most adversely affected by the short duration impulses and vice versa.

h. Manufacturers attempt to build some protection into their equipment but competition limits what they can do economically. The Information Technology Industry Council (ITI) sets guidelines for such protection by suggesting an ac input power profile envelope shown in appendix B. They suggest that information technology equipment should be designed to meet these guidelines. However, even if the equipment were designed to this power profile guide, the envelope does not cover the power profile of the utilities supplying the power.

i. Power companies attempt to provide the cleanest and most stable power (input voltage) to their customers. There is very little attempt to constrain anomalies shorter than one half cycle (8.3 milliseconds); i.e., impulses, EMI, RFI. The input power line may carry short duration variations (less than 8.3 milliseconds duration) whose voltage amplitudes can be hundreds of times greater than nominal. These "Type I disturbances" are often damaging to electronic equipment. Between 8.3 milliseconds and 0.5 second the power line may still vary as much as +30 percent to -40 percent of nominal. These "Type II disturbances" (sags and swells) may also adversely affect the equipment as will the "Type III disturbances," voltage dropouts, and overvoltages."

(1) To counteract these conditions and protect computerized equipment from these anomalies, the ITI recommends that all computerized equipment be designed to operate within the set guidelines. Equipment designed and manufactured to meet this recommendation should then withstand any variations within the guidelines. Therefore, an impulse with voltage amplitude less than 200 percent of nominal rated RMS and shorter than 100 microseconds duration should not adversely affect the equipment. Neither should those less than 100 percent and shorter than 1 millisecond or less than 30 percent and shorter than 8.33 milliseconds.

(2) Engineers from IBM conducted a study from which they were able to determine the incidence rate of harmful power line disturbances. They studied a large number of installations over an extended period of time and in 1974 published their findings in a document [1] "Monitoring of Computer Installation for Power Line Disturbances," G. W. Allen and D. Segal, Institute of Electrical and Electronic (IEEE) Winter Power Meeting Conference Paper C74-199-6. The results showed that 88.5 percent of power line disturbances were Type I disturbances, 11 percent were Type II disturbances, and 0.5 percent were Type III disturbances. Type I, II, and III disturbances were defined as having durations of less than 0.5 cycles, 0.5 to 120 cycles, and greater than 120 cycles, respectively.

(a) While Type I disturbances are the most damaging to equipment and data, even Types II and III can be of great importance for customers who cannot tolerate the inconvenience and high cost of downtime or erroneous data, loss of data, etc. There will be many cases where a customer may need and be willing to go to great expense to eliminate even the least frequent of these occurrences.

(b) Electronic chips have become denser – more than one million components on a small chip – and are thus even more susceptible to Type I disturbances. Utilities are attempting to hold closer tolerances on the voltage, and yet, sags and swells (Type II) and outages (Type III) are on the increase.

(3) Recent studies have redefined Type I, II and III disturbances as transient, momentary and steady-state disturbances respectively. Transient disturbances include unipolar transients, oscillatory transients (such as capacitor switching), localized faults, and other events typically lasting less than ten milliseconds. Momentary disturbances are voltage sags, swells, and interruptions lasting more than ten milliseconds but less than three seconds. Steady-state disturbances are undervoltages, overvoltages, and interruptions that last three seconds or longer.

2-4. Power quality parameters

The quality of electrical power can be severely affected by oscillatory decaying transients. These would be the result of lightning or some other sharp electrical “hit” that would excite the natural frequency of the subject electrical system (much like a tuning fork is excited). The electrical system will then ring at its natural frequency, f_n (different electrical systems have different natural frequencies just as different mechanical systems have different natural frequencies), defined as:

$$f_n = 1/(2\pi(LC)^{1/2})$$

The amplitude of the natural frequency (voltage in this case) will then decay at an exponential rate dependent upon the stiffness of the electrical system, amount of wiring, wire sizes, layout, etc. Due to the fact that induced lightning can be one of the initiators of this oscillatory action, the initial amplitude (voltage) of the resultant sinewave can be very high (thousands of volts) and may contain a lot of energy (thousands of joules).

a. Data lines and instrumentation lines, while not directly affected by power line problems, can be adversely affected if located in close proximity to power lines or if located where they can be affected by induced lightning transients. Power lines or power wiring and control wiring can induce noise into data and instrumentation wiring when it is run parallel to them. Transients on the power lines paralleling data lines can also be induced onto these low voltage lines and damage data or instrumentation equipment. As little as 10 volts applied to a transistor-transistor logic (TTL) circuit for only 30 nanoseconds will cause the destruction of the TTL junction. Data line instrumentation should never be run in close parallel proximity to power and control voltage lines.

b. The affect of lightning transients may be reduced by using shielded cable for data transmission, and instrumentation care must be taken to ground the shield on these cables only at one end of the cable run to prevent induced circulating currents.

c. Data and instrumentation cable, run underground, should be buried at least 4 feet down to protect from lightning. Lightning striking the ground can raise the ground potential and induce transients into underground wiring not encased in steel pipe. Most buried cable is now encased in either polyvinyl chloride (PVC) or fiberglass if not directly buried and, therefore, is subject to lightning inducted transients if buried too close to the surface. Data and instrumentation cable inside buildings should never be run closer than 5 feet to an outside wall in a high lightning area for the same reason, induced transients from nearby or direct lightning strikes.

2-5. Detection of power line anomalies

Instrumentation has been developed to record and better understand the power line disturbance phenomena. Iron vane meters were developed to read voltage, current, frequency, and then power to enable operators to maintain constant voltage and frequencies and read current values. Then came recorders to supply a constant record of these events. As long as the major interest was only in the areas of no voltage, high and low voltage, sags, and surges, these instruments were sufficient.

a. Electronics brought in a new dimension; higher data frequencies meant that things happened faster and new instrumentation was developed to read and record these events, recording oscillographs and oscilloscopes. The higher frequency, faster electronics were also more susceptible to the higher frequency anomalies on the power supply line. Power line noise (EMI) and impulses were mistaken as data by the electronics and processed as such. Solid-state electronics and the microprocessor chip brought us high density – thousands and millions of solid-state components on a small 1/4” by 3/8” chip. The low voltage requirement of these circuits and the high density made them extremely susceptible to even minor overvoltages. A TTL junction will be destroyed at only 10 volts.

b. Due to the randomness of the power line anomalies, it became necessary to develop high-speed event recorders to detect the presence of the high-speed anomalies: noise and impulses. Such an instrument will measure and record only the event itself. The occurrences of events can be recorded for later analysis without the requirement of the constant presence of the operator or the accumulation of meaningless recorded data. A general discussion is presented below of two different power line monitors, which can record and analyze power disturbances.

(1) The first monitor, called the “universal disturbance analyzer” is extremely versatile and because of this feature requires greater skill to set up and operate. If limits are not properly chosen and programmed in, and depending upon the “print-out mode” chosen, the user can either end up with insufficient data upon which to base corrections decisions or with large amounts of superfluous data to wade through to determine what problem needs to be corrected. Such data to the untrained individual may lead them to believe that one problem exists when the problem is really something else. For instance: one might be misled to believe that sag-surge problems existed because of reams of sag-surge data when in reality the limits had been set so low that what was actually recorded was a lot of normal voltage fluctuations well within the permissible limits set by equipment manufacturers and governing bodies; i.e., fluctuations not harmful to equipment. However, when properly set up, this type of instrument can produce much valuable data for the experienced user.

(2) The second monitor, called the “power line consultant” does not have the versatility of the first. However, this lack of versatility results in ease of set up and eliminates questions regarding the validity of the final data. This instrument can produce all the data required to make an intelligent decision about a problem, and therefore the proper correction device, without the skill needed with the first instrument.

CHAPTER 3

POWER CONDITIONING

3-1. Information technology equipment power requirements

Typical applications of information technology equipment are computer networks, communication systems, server farms and their peripherals, customer-owned telephone switching systems, and increasingly complex electronic industrial control equipment. Faulty performance of these units can cause inconvenient, expensive, and even dangerous situations. These electronic circuits in this equipment operate on dc power. The source of this power is an internal dc power supply which converts (rectifies) the ac power furnished by an electric utility to the various dc voltage levels required by the electronic equipment. Internal dc power supplies are designed to isolate the electronic equipment from moderate disturbances on the ac power lines. But the fact is that frequently types and levels of power line disturbances are encountered which pass through internal power supplies. This causes aberrations in the dc voltage levels, which can result in everything from faulty operation to complete shutdown or failure of the electronic equipment. One of the major problems when electronic equipment performs incorrectly or shuts down unexpectedly is locating the source of the trouble. Scrambled data in a recirculating memory can, for example, look like a hardware or software failure on the surface whereas it might actually have been caused by an intermittent blip on the power line. It is, therefore, important that a user know something about the kinds of disturbances that appear on his power line and how often they occur. This does away with much of the finger pointing by the user and various service personnel when a problem does arise, and at the same time permits steps to be taken to prevent these disturbances from reaching the dc power supplies. The proper choice of equipment designed to isolate the power supply from line disturbances is wholly contingent on the precise types of power line disturbances expected, the estimated frequency of occurrence, and the importance to the user of keeping the electronic equipment on line.

a. Electronic equipment used in computers operates on dc power equivalent to that obtained from an ordinary battery. It is a single-polarity (either plus or minus) and is derived by converting or rectifying the ac power supplied by a utility. Typical dc levels required by solid-state electronic equipment are plus or minus 5, 12, 15, and 24 volts. Power line disturbances, which pass through a power supply, can cause dc voltage levels to rise or fall slowly or rapidly, exhibit positive or negative spikes, or even drop to zero. Any of these occurrences can cause faulty equipment performance, system shutdown, or even damage to sensitive electronic components.

b. The ac power generated by electrical utilities is characterized by alternating back and forth between equal positive and negative voltage levels along a pure sinewave wave form. Because of the sinewave characteristics there are various ways of describing ac power. The nominal 120 volts from an outlet is actually the effective or root mean square (RMS) voltage of the ac wave. It is equivalent to 120 volts dc when supplying a pure resistance load such as an incandescent light bulb – thus the name effective. The negative and positive peak voltages are equal to 1.414 times the RMS voltage, while the average one-cycle voltage is equal to 0.637 times the positive or negative peak voltage. Thus for our 120-volt outlets, the peak voltages are equal to 120 times 1.414 or 170 volts, while the average voltage equals 170 times 0.637 or 108 volts. In turn, of course, the RMS voltage is equal to 0.707 times the peak voltage. In the United States, ac power

is generated at a frequency of 60 hertz or cycles per second (in other countries 50 hertz power is common). This means there are 60 full sinewaves per second so that a cycle is 16.7 milliseconds long.

(1) Utilities supply residential structures and commercial and industrial offices with single-phase ac power. Usually there are three-wire systems with two “hot” conductors and a neutral. The neutral is grounded at the service entrance (normally to a water pipe) and this ground lead or a ground connection is carried throughout the system. One hot lead, the neutral, and the ground connection are carried to the standard 120 volt outlets. Under proper operating conditions only the hot and neutral leads carry current; the ground connection is for safety purposes. If there should be an insulation breakdown in the energized equipment, the ground connection will drain the current back to ground, thus preventing personnel exposure to 120 volts.

(2) For higher powered equipment, such as ranges, air conditioners, electric heating, clothes dryers, and some office equipment, the two hot conductors and ground are wired to special outlets. This yields 240 volts and halves the current that would be required if the same equipment was designed to operate on 120 volts.

(3) For large electric power users, utilities generate and transmit three-phase ac power in which the three phases are time phased by one-third cycle, effectively producing three ac wave forms. Three-phase power is less expensive to transmit, simpler to rectify into low-ripple ac voltage, and three-phase ac motors are simpler and operate more smoothly than single-phase motors. The single-phase residential power mentioned above is obtained by tapping off one phase of a three-phase transmission line.

(4) Every industrial facility and most large computer installations are supplied with three-phase power. The most popular configurations for supplying this three-phase power are the four-wire “wye” with ground and the ungrounded and grounded “delta.” Wye circuits can usually handle either 480 volt or 208 volt three-phase loads and 277 volt or 120 volt single-phase loads. The 120 volt level is, of course, that obtained from the standard ac outlet, whereas 277 volts is a popular level for fluorescent lamp fixtures. Both types of delta circuits normally supply either 480 volt or 240 volt three-phase loads.

3-2. Power line disturbances

All of these types of ac circuits are susceptible to line disturbances which may either be introduced via the utility’s transmission lines or generated internally within the user’s own facility. Breaker tripping and reclosure for fault clearance, random switching of heavy loads, lightning strikes, noise, motor controllers, and an endless number of similar occurrences can and will introduce ac line disturbances about which the utility can do little. With the exception of frequency variations, all power line disturbances are voltage phenomena. Fluctuations of the RMS voltage value over an appreciable time interval are known as undervoltages or overvoltages, shorter term variations are called sags or swells, and spikes or transients of very short duration and considerable peak magnitude are known as impulses. Dropouts or line interruptions are where the line voltage goes to zero, a situation that can exist for any time period.

a. Any RMS voltage fluctuation which exceeds allowable limits for more than 1 minute is classed as an undervoltage or overvoltage.

(1) Undervoltage situations are normally caused by purposeful utility “brownouts” and/or line overloading either within the same facility or by neighboring facilities on the same

transmission line. Utilities cause brownouts by deliberately dropping the voltage by three, five, or even eight percent to extend system capability, particularly on hot days with heavy air-conditioning loads and limited reserve.

(2) Overvoltage is caused by poor line regulation by a utility or by lighter than expected loads on the line. If, for example, an emergency forced several neighboring plants to shut down during the normal working day, transmission line voltage would undoubtedly rise until the utility could bring it back under control.

(3) Overvoltage causes electronic equipment to run hot, stressing components and possibly prompting immediate or incipient failures. Equipment shutdown may also occur if the heat dissipation forces the enclosure to reach unsafe high temperatures and a thermal limit trips. Normal utility voltage variations, plus internal facility feeder line voltage drops and the ever present possibility of brownouts in certain sections of the country, make undervoltage situations fairly common. If the voltage drops sufficiently, all kinds of erratic performance can be expected as electronic equipment nears the point where it will stop operating completely. Also, motor loads draw more current and run hotter and less efficiently under low voltage conditions.

b. Sags and swells are short-term special cases of undervoltage and overvoltage conditions where the voltage fluctuation exceeds the allowable limit for at least some significant portion of one cycle (say 10 milliseconds) and reenters the limit band within 1 minute. Because sags and swells are transitory conditions caused by momentary occurrences, they usually exhibit larger voltage excursions than longer term undervoltages and overvoltages.

(1) Swells look the same as sags except that the voltage exceeds the upper limits that are usually established at 10 percent. Sags are most commonly caused by switching on to the line heavy loads such as large motors, electric furnaces, substantial air-conditioning capacity, etc. Such loads draw heavy inrush currents, which drop the voltage for short periods and line voltage regulation typically takes a definite period to recover from such heavy loads. Swells are frequently caused by the reverse – the disconnecting of heavy loads from the line with the accompanying voltage increases.

(2) If sags or swells have sufficient magnitude to be reflected through the internal dc power supplies, they can play havoc with the performance of sensitive electronic equipment. For example, equipment designed to initialize upon startup may re-initialize after a severe sag – it confuses the sag with the turn off and turn on of power. And much electronic equipment shuts down and stays shut down if the voltage drops below a limit for more than a few milliseconds. Particularly disruptive situations can occur if part of the equipment in an integrated system starts up after recovery from a sag and the balance of the equipment does not.

c. Impulses are deviations from the ideal ac sinewave having very short duration compared with one cycle – typically from a fraction of a microsecond to a very few milliseconds. Their forms range from single pulses with extremely short rise time and gradual decay to oscillatory disturbances persisting for five to ten oscillations within a gradually decaying envelope. They may either increase or decrease the instantaneous amplitude of the sinewave described as a “spike” or “notch,” respectively.

(1) Impulses can range in magnitude from a fraction of peak voltage up to hundreds or thousands of volts and by far cause the largest voltage swings of any types of line disturbances. The proper way to examine an impulse disturbance is to filter out the sinewave. If any impulse spike with a magnitude of 500 volts occurred at the top of a nominal 120 volt sinewave, then the

actual voltage impressed on the load would be 500 volts plus the peak instantaneous voltage ($1.414 \times 120V = 170V$) of 170 volts or 670 volts.

(2) Two other measures of an impulse disturbance are impulse duration and impulse strength. Impulse strength is defined as the volt-second area under the impulse curve. It is clear that impulse strength and impulse duration are related and either adds a significant measure to the knowledge of the problems a transient can cause beyond the straightforward measurement of impulse magnitude by itself.

(3) It is also important to know the direction or source of an impulse. Did it occur at the source of power via the utility power feeder or was it generated in the electronic equipment? Either is possible, and of course, the solutions to the two problems are radically different.

(4) There are two types of impulses: common-mode transients where the voltages to ground of the ac power line phases rise and fall together, and normal-mode transients where the phase-to-ground voltages vary from phase to phase. Common-mode impulses are caused by such things as lightning and utility breaker tripping and reclosure, usually resulting in single spikes or notches on the sinewave. In contrast, normal-mode impulses are typically the result of connecting or disconnecting heavy loads or power factor compensating capacitors. These impulses exhibit decaying oscillatory characteristics with frequencies up to and above 5 kilohertz (kHz). It is important to know the type of impulse since the means of suppressing them are different.

(5) Impulses are the most insidious type of power line disturbance. They occur without any indication at all to operating personnel, and if not suppressed can cause scrambled data transmission or memory data resulting from bit changes, over-stressed components, or even component failure.

d. Loss of total power to zero voltage can occur for any time period from a portion of a cycle on up to hours or even days. Very short-term dropouts are frequently caused by utility breakers tripping to clear a fault and then reclosing automatically, while long-term line interruptions can result from any serious utility problem – power lines felled by a storm or fires in substations are typical. Most computers and sensitive electronic equipment, which depend on digital data manipulation, will shut down automatically if a power dropout exceeds a very few milliseconds.

e. Frequency deviation is seldom a problem with utility-supplied power in the United States. Frequency rarely varies more than 0.5 hertz from 60 hertz (a common computer specification) and is always averaged out over a 24-hour period because of the number of clocks and other time-based devices, which depend on constant frequency for accuracy. However, if power is generated locally by a private power plant or by motor-generator (M-G) sets or diesel or gas turbine engines, frequency can wander over a 10 hertz band from 55 to 65 hertz. Frequency shifts of this magnitude can cause problems with time-based equipment or frequency-sensitive circuits.

3-3. Acceptable limits for ac power

Although there are no industry standards to define “acceptable” ac power, the Information Technology Industry Council (ITI) has issued a guideline (shown in appendix B) that describes the ac input voltage envelope which typically can be tolerated by information technology equipment. The various sags, swells, undervoltages, overvoltages, and impulses exhibited by a power line can be classified as acceptable or unacceptable based on whether they fall within or without the dashed-line boundaries. In these guidelines, long-term overvoltages or undervoltages

which deviate from the nominal voltage by more than +10 percent or -20 percent for longer than 500 milliseconds (30 cycles) can be expected to cause problems. Any swell or sag, which exceeds +20 percent or -30 percent of the nominal voltage for more than 20 milliseconds (1.2 cycles), is apt to cause faulty operation of IT equipment. The impulse band is more difficult to define because of the frequent high magnitude of the transients, but, generally speaking, impulses greater than the nominal peak sinewave voltage can degrade a system's operation. If monitored power line disturbances fall outside these boundaries, particularly during pre-installation site inspection, a careful analysis may avoid future problems.

3-4. IT protective equipment

Although it is difficult to make any generalizations concerning the benefits that accrue from the use of line protective equipment, it has been estimated that clean power versus that taken directly from the "average" power line reduces load equipment outages by 40 percent and maintenance costs by 25 percent. The choice to use protective equipment is both an economic and technical consideration. The wide range of power line conditioning and isolating equipment varies greatly in price and in the types of disturbances it will protect against. Less expensive protective equipment may not provide much improvement and costly equipment for every conceivable power line problem may not be economically justifiable.

a. Once the profile and estimated frequency of occurrence of line disturbances via power line monitoring is determined, an economic analysis should be performed. This analysis should include a complete life cycle cost analysis associated with purchasing and operating the protective equipment, the costs incurred as a result of load equipment outages, faulty performance, hardware damage, and any other anomaly that may occur for various degrees of power line protection.

(1) Costs to consider are the mission requirements, initial purchase price of line conditioning or isolating equipment, installation costs and operating costs. Within these, consideration should be made for site preparation, equipment operating efficiency, and maintenance requirements.

(2) Site selection and preparation may be a major contributor since some line conditioning equipment may require special space and site preparation. In new building construction, space limitations may not be a problem, but space may be a major factor when a large computer installation in an existing facility requires retrofitting.

b. Special factors requiring consideration prior to selection of protective equipment are as follows.

(1) Transformer hum or rotating equipment noise may require a sound baffled enclosure or location away from occupied areas.

(2) Large battery banks in some uninterruptible power supply (UPS) systems are heavy and require substantial surrounding space to permit proper maintenance. In addition, certain battery types also generate explosive fumes. Therefore, an isolated space with forced ventilation and extra reinforcing because of heavy floor loading may be required.

(3) Environmental conditions must also be considered if the load protective equipment is located in the same space as the computer or other electronic load devices. The line conditioning and isolation equipment generates heat, which may require additional air-conditioning capacity.

(4) Equipment efficiencies must also be considered in the cost. No load protective equipment is 100 percent efficient, and efficiencies may range from as low as 50 percent to a high 96 percent. This electrical energy incurs a cost with the efficiency of some types of protective equipment decreasing with time so this continuing cost may increase as the equipment ages. Obtain efficiency rates from the equipment supplier for the actual conditions under which the equipment will be operating.

(5) Equipment maintenance is a continuing expense, which must also be considered. All electronic systems require periodic inspection and will fail from time to time. Modular plug-in construction and diagnostic aids speed troubleshooting and repair, but parts and labor still cost money. Batteries require periodic monitoring of electrolyte and terminal cleaning, and all rotating equipment needs, at minimum, regular bearing inspection and occasional bearing replacement. Backup engine-driven alternator sets have particularly high maintenance costs.

c. Isolation transformers used for protective devices are primarily intended to attenuate common-mode impulses. Some types also provide limited attenuation of normal mode impulses. Isolation transformers perform no voltage regulating function. Sags, swells, undervoltages, or overvoltages will be reproduced faithfully on the transformer secondary. If the power line voltage is consistently stable and high frequency impulses or noise is the only problem, then a suitable isolation transformer may eliminate your power line disturbance difficulties.

(1) While a standard transformer has no dc connection between primary and secondary, the windings are ac coupled through an infinite number of coupling capacitances. At high noise frequencies, these capacitances have relatively low impedance and transfer the noise directly from primary to secondary. Thus a standard transformer has practically no ability to attenuate impulse noise but instead passes it right through.

(2) The basic isolation transformer helps this somewhat by inserting an aluminum foil electrostatic Faraday shield between the primary and secondary windings. While this shield does not completely eliminate this coupling capacitance, it shunts a lot of it to ground and thus minimizes the transformer's ability to transfer common mode impulses. Power line noise on the primary is considerably attenuated by the time it reaches the secondary.

(3) The ultimate isolation transformer (variously called high, super, ultra, etc., by different suppliers) further reduces this coupling capacitance with box electrostatic shields around the primary and secondary windings. Capacitances between the windings and the frame and windings are broken up into smaller series capacitances and shunted to ground, thus minimizing input-to-output capacitance of 0.001 pico-farads, and the better ones are as low as 0.0005 pico-farads. This very low level of coupling capacitance effectively prevents common mode impulses on the power line from reaching the load.

(4) Attenuation capability for a top quality isolation transformer is expressed in decibels (dB), a shorthand way of indicating attenuation ratios. The higher the dB rating the isolation transformer has the better the noise attenuation. Well designed dc power supplies exhibit considerable normal-mode noise attenuating capability.

(5) High quality isolation transformers are available in sizes ranging from 125 VA single-phase to 130 kVA three-phase. Isolation transformers with somewhat lower levels of impulse attenuation are also available. There are many different suppliers with various quality level transformers so almost any specific performance requirement can be satisfied.

d. Line voltage regulators do exactly what the name implies – their purpose is to maintain reasonably constant output voltage to the load in the face of variations in power line voltage. There are many different ways of accomplishing this and among the basic types there are innumerable variations, all with their own advantages and limitations. The following covers one or two popular or generic versions of five basic types of voltage regulators.

(1) Most line regulators will correct utility voltage sags and swells of 15 percent to output voltages to the load ranging from ± 3 to ± 7 percent of nominal. Many will bring extreme utility sags in the area of 20 to 30 percent, back to ± 7 to ± 10 percent of the nominal output voltage. Some things to consider when picking a line voltage regulator are cost, speed of response, output impedance, audible noise, efficiency at part and full load, sensitivity to load power factor and unbalanced three-phase loads, and harmonic distortion.

(2) A few types of line regulators can attenuate impulses to a modest degree, but most perform the regulation function only and pass impulses right through. In fact, some types may create additional impulse noise by internal switching.

(3) There are two types of motor-actuated regulators, the motor-driven brush type and the induction regulator type. The motor-driven brush type moves across many taps on an autotransformer, causing the series transformer to buck or boost the voltage to the load. The same function is performed by an induction regulator where rotating the regulator one direction or the other varies the magnetic coupling and raises or lowers the output voltage.

(4) Motor-actuated voltage regulators are generally inexpensive and can handle heavy loads, but they are slow in response and can only correct for gradual voltage changes. In addition, their electro-mechanical parts require substantial maintenance and output impedance is high. They are not often used with critical and sensitive electronic equipment.

(5) The saturable reactor regulator controls output voltage by varying the impedance of the saturable reactor winding in series with a step-up autotransformer. These regulators are relatively inexpensive, and have a wide load range, low maintenance requirements, and yield fair normal-mode impulse protection. However, the disadvantages often outweigh these plus factors. Sag/swell response is sluggish (in the range of five to ten cycles), output impedance is high (as much as 30 percent of the load impedance), and they are sensitive to lagging load power factor.

(6) The ferro-resonant transformer voltage regulator is one of the more popular regulators, especially in the lower size ranges of 0.5 to 2 kVA. The ferro-resonant transformer core structure is designed so that the secondary operates in flux saturation and the secondary winding resonates with the capacitor in a tuned circuit. As a result of this saturated operating mode, changing the primary or line voltage may change the current but will not vary the flux or the secondary induced voltage. Thus the unit performs a voltage regulating action. A unique characteristic of the ferro-resonant regulator is its ability to reduce normal-mode impulses. Since its regulating capability is based on driving the secondary winding into saturation, transients and noise bursts are clipped.

(*a*) The basic ferro-resonant transformer puts out a high harmonic content squarewave, not suitable for supplying sensitive electronic loads. A properly selected neutralizing winding cancels out most of the harmonic content of the output voltage and yields a satisfactory low-distortion sinewave.

(b) The ferro-resonant regulator has a response time of about 25 milliseconds or 1.5 cycles, good reliability, minimal maintenance requirements, reasonable cost, good normal-mode impulse attenuation, and good regulation. Because of the tuned circuit on the output, it is sensitive to frequency variations (One percent frequency change causes 1.5 percent output voltage change), but this is not much of a problem with tight utility network frequency control. More important are its high output impedance (again up to 30 percent of load impedance), sensitivity to both leading and lagging load power factors, and low efficiency at partial loads. Efficiency is about 90 percent at rated load, but since the unit wastes about 10 percent of rated load regardless of what load level it is operating at, efficiency drops with load. This, in turn, results in heat dissipation and the generation of audible noise.

(c) In addition, ferro-resonant regulators have poor capacity for handling momentary overloads such as might be caused by high motor starting current, and output voltage collapses at somewhere about 150 percent of full load. Oversizing is not the whole answer to this problem, since this causes reduced efficiency and increased heat dissipation. In summary, the ferro-resonant regulator is useful in small systems that do not contain large motors.

(7) The last type of line voltage regulator to be looked at here is the electronic tap-switching autotransformer. With this unit the proper triac (or back-to-back silicon controlled rectifier [SCR]) is energized depending on whether the power line voltage must be increased or decreased. Voltage correction occurs in discrete steps rather than continuously. Resolution depends on the closeness of the taps, and switching impulses are minimized by changing taps when the line voltage is near a zero crossing.

(a) The electronic tap-switching transformer has many good features. Response time is fast at about 0.5 cycles or 10 milliseconds, regulation is good, output impedance is in the range of five percent of load impedance, efficiency is high at about 95 percent, and the units are insensitive to load power factor and load unbalance.

(b) The disadvantages are a somewhat high cost and slightly poorer reliability when compared to the more rugged units.

(c) This type of regulator is popular and widely used in the medium sizes of 3 kVA and up.

e. Line conditioners combine the functions of isolation transformers and line voltage regulators and thus both attenuate impulses and regulate output voltage. For this reason, a line conditioner can protect against the principal types of power line disturbances except for voltage dropouts and line interruptions. It is possible to create a line conditioner by placing separate voltage regulators and isolation transformers in series. Properly matching the two can be tricky, and the package is bulkier and generally more expensive than using a single unit designed to perform the total line conditioner function. Care should be taken not to place two devices in series that have resonant characteristics (e.g., ferro-transformer and certain types of UPS). This can cause circuit detuning resulting in failure of equipment to perform its function.

(1) There are basically two types of packaged line conditioners on the market, regulating line conditioners and enhanced isolation transformer line conditioners. The first uses an improved ferro-resonant transformer voltage regulator, while the second includes an electronic tap-switching voltage regulator in conjunction with a high quality isolation transformer.

(2) The ferro-resonant transformer line conditioner is more popular, being lower priced and highly reliable. The box and Faraday shields around the primary and compensating windings give it essentially the characteristics of a high quality isolation transformer in series with a ferro-resonant voltage regulator. The expected normal-mode impulse attenuation from the saturated operation of the ferro-resonant transformer, plus the electrostatic shields, make this line conditioner a good attenuator of both common-mode and normal-mode impulses.

(3) A typical high quality line conditioner should regulate output voltage to within ± 4 percent of nominal for ac input power line voltage changes from -20 percent to $+10$ percent. Total harmonic distortion (THD) will be less than 5 percent, and both types of impulses should be attenuated up to 120 dB. Other features may include electromagnetic interference/radio frequency interference (EMI/RFI) noise filtering and quality transient voltage surge suppression on the output of the line conditioner as almost all line conditioners are intended to serve multiple loads.

f. M-G sets consist of a motor driving an ac generator or alternator so that the load is completely electrically isolated from the power line. In the past, in some cases dc or induction drive motors were used requiring close speed control to maintain stable frequency to the load. The tendency nowadays is to use induction or synchronous motors. The synchronous motor resembles an induction motor but runs at synchronous speed. With either of these unit types, alternator speed and thus frequency to the load is as stable as power line frequency. M-G sets have been widely used to supply 415 hertz power to the mainframe computers which require this frequency, but recently there has been a substantial shift to the use of solid-state inverters.

(1) M-G sets shield the load from impulses and from voltage sags and swells. For substantial power line voltage changes of ± 20 percent or more, voltage to the load is still maintained at ± 1 percent of nominal. The unique feature of the M-G is its ability to bridge severe short-term sags or voltage dropouts. The rotational momentum of the rotating elements permits the M-G to span dropouts of up to about 300 milliseconds or 0.3 seconds, the type that cause lights to flicker and plays havoc with digital circuitry. This period can be extended by adding inertia via a flywheel.

(2) The problems with M-G sets are mostly on the output or load side. Very high alternator output impedance can cause substantial voltage dips in response to sudden load changes such as result from large inrush motor starting current, and response to load changes is sluggish in the range of 0.25 to 0.5 seconds. Also, the drive motor may overheat under long-term brownout or low line voltage conditions.

(3) The cost of a M-G set is somewhat more than for a functionally equivalent line conditioner. Also, M-G efficiency is relatively low at about 80 percent, so that electrical energy costs over its lifetime may be substantial. Heat dissipation, weight and bulk, and the potential for annoying audible noise are factors which must be considered in M-G installation. The use of rotating field exciters has eliminated the need for slip rings, with the consequent brush inspection and replacement, but as with any rotating equipment, bearings must be inspected and periodically replaced.

g. If continuous operation is necessary during a line voltage interruption lasting more than a half second or so, then an UPS is required. The basic UPS consists of a rectifier/battery charger, battery bank, and inverter. The rectifier/battery charger takes ac line power of the proper voltage and frequency and generates dc power. The battery bank takes the place of the rectified dc power source if line power fails. The inverter with suitable filtering converts the dc power back into a

sinusoidal wave form. UPS systems are complex, expensive, have high output impedance, and frequently require special installation facilities and increased air-conditioning capacity to dissipate the heat. The proper UPS will protect the load equipment from all types of power line disturbances.

(1) The size of the battery bank determines the length of time the inverter will supply normal power to the load. For a large computer installation this time is usually about 15 to 20 minutes. This would be enough time to perform a soft shutdown of equipment if the generators did not come on line. Certain mission requirements may require additional battery time. An alarm is activated when five minutes of battery time remains to permit orderly shutdown. If the load equipment does not require special air conditioning (most process control systems and medical electronics, for example) then it is practical to size the battery bank to cover more extended outages. In this situation, up to an hour of running time is not uncommon and much longer periods are possible.

(2) There are various ways of employing a UPS. The specific configuration to be used is largely dependent upon the reliability of power required by the load.

(a) Continuous mode describes the configuration whereby the load power is always obtained from the UPS except during UPS failure or periods of required maintenance. In this case, the load is manually switched to the raw power line via the maintenance bypass line, causing substantial discontinuity in load operation.

(b) In the forward-transfer mode, the load is normally supplied from the utility power line and the UPS idles. When power fails, the load is automatically transferred to the UPS. In normal operation with this configuration there is no load protection from power line disturbances, except for severe sags and voltage outages, unless other load protection is installed in the utility power line. This tends to defeat the major objective of the UPS.

(c) More popular is the reverse-transfer mode configuration. Here, the load is normally supplied by the UPS and is automatically switched to the utility power line only when the UPS malfunctions. This mode provides maximum benefit from the UPS.

(d) If more extended protection is required, further backup via an engine-driven generator must be added. Here, battery time is usually only about 5 minutes – long enough to get the engine-driven generator up and synchronized with inverter output. Of course, such an installation is very expensive and requires special facilities and substantial maintenance. It should only be considered if extended power outages are frequent and continuity is critical.

(e) For very critical situations there are other configurations that can be considered, including double- and triple-redundant UPS systems backed up by multiple engine-drive generators.

(3) An especially sensitive element, in terms of continuity of service, is the type of automatic transfer switch, which is used. The electro-mechanical transfer switch is actuated when the sensed output voltage to the load drops below 94 percent of nominal. However, sense and switch time ranges from 20 to 50 milliseconds. This time delay will cause most sensitive load equipment to severely malfunction or even shut down. The static transfer switch is much faster. It switches upon sensing a failure in inverter input circuitry, a drop in load voltage to 94 percent of nominal, or overload on the inverter exceeding 130 percent of full load. The sense and switch time is only about four milliseconds, so there is a good chance the load's dc power supply

will ride right through this short delay and the load will see no discontinuity. Of course, in all transfer situations inverter output must be phased with the power line.

(4) Several different types of inverters used in the UPS system are available. The type that is included in a UPS depends to some extent on the power level requirements for the UPS and on the particular tendencies of the supplier.

(a) The pulse-width-modulation inverter incorporates two inverters, which regulate by varying the pulse width and yield an output, which closely resembles a sine wave. This reduces filter requirements and provides good voltage regulation and response times in the range of 100 milliseconds. However, the extra inverter and feedback networks make this inverter complex and expensive, and it is usually used only at power levels over 50 kVA.

(b) The most popular inverter type in the smaller size ranges is the ferro-resonant unit. It consists of an oscillator, which controls the SCR switches, a ferro-resonant transformer, and a harmonic filter. Its saturated operation produces a regulated output voltage and current limiting, so complex voltage and current feedback networks are not required. Efficiency varies from 50 to 88 percent depending on load level, and response time is about 20 milliseconds. The simplicity of this inverter leads to relatively low cost.

(c) SCRs are used in the inverter section of most large UPS products. A SCR is a semiconductor device with unique properties. It can serve as a rectifier and as a static latching switch. It can handle more power (both voltage and current) than typical transistors, under both continuous and surge conditions. It is the most rugged semiconductor available, and in most cases, can handle more watts per dollar than other types of semiconductors. The SCR serves as an on-off switch. The SCR can be turned on by a momentary application of control current to the gate, while transistors require a continuous on signal. The SCR can be turned on in about one microsecond, and static switch sections turned off in 10 to 40 microseconds. The SCR is ideal for rectifier UPS products, but has disadvantages when applied to inverter sections.

(d) In recent years manufacturers have been changing over to transistorized inverters in their UPS products. A transistor permits current to flow through a circuit when the base drive of the transistor receives an electrical signal. Transistors are not latching devices, so they can be turned off by simply removing the base drive signal. To minimize switching losses, however, special drive circuits are required to turn the devices off quickly. Transistors also experience saturation losses during the conduction stage of the cycle. A transistor is considered efficient if it has high "gain" – when relatively small amounts of drive current applied to the base permit a comparatively large current to flow in the collector emitter circuit.

(e) Bipolar transistors produce gain by current conduction. A current applied to the base causes a proportional current to flow in the collector/emitter. A special type of bipolar transistor is called a Darlington, which consists of two transistors linked together. The collector/emitter of the first transistor is used to activate the base drive of the second. Darlington transistors have a higher gain than a single bipolar and are easier to control. The disadvantage is that they have higher saturation losses and require special drive circuits to minimize switching losses.

(f) Field-effect transistors (FETs) work differently than bipolars. They do not inject current into the base. Instead, they conduct when they sense a voltage on the gate. This means that relatively little power is consumed in the gate drive. However, the power-conducting portion has a relatively high resistance. This creates excessive losses and lower efficiency, making it unsuitable for use in large UPS products.

(g) Insulated gate bipolar transistors (IGBTs) combine the best of conventional bipolar transistors and FETs. Like FETs, they only require a voltage across the base in order to conduct. However, like conventional bipolars, they are efficient conductors of current through their collector/emitters. IGBTs are the preferred transistors for UPS applications. They are significantly more efficient and are easier to control than any other power semiconductors. IGBTs are commonly available for UPS applications up to 750 kVA without paralleling devices. Larger devices are available, but have not achieved as much market penetration.

(5) The battery charger/rectifier system operates in a constant-current mode during the initial charge period, automatically switching to a constant-voltage mode towards the end of the charge cycle. This gives maximum battery life consistent with fast recharge, and prevents excessive battery outgassing and water consumption. The charger provides a float voltage level for maintaining the normal battery charge, and sometimes, a periodic higher voltage to equalize certain types of batteries. There are several different types of batteries generally selected for UPS applications. The most common types break down into two technologies: lead acid and nickel cadmium (NICAD). Lead-acid batteries are further broken down into two types: lead-acid/calcium and lead-acid/antimony. Lead-acid calcium batteries can be divided into two categories, wet cell (or flooded) and valve-regulated lead acid (VRLA) sometimes mistakenly referred to as maintenance-free.

(a) The sealed VRLA lead-calcium battery uses either a gelled electrolyte design (GELL), or an absorbent glass mat (AGM) design, does not require the addition of water, and has no problems with outgassing or corrosion. This type is used when the batteries are integral to small UPS systems, and where the batteries must be placed in occupied areas. Their big disadvantage is a limited life span of about five years under optimum conditions. Conventional wet cell lead-calcium batteries are the preferred type in most UPS systems. Watering and terminal cleaning are required only about every six months and manufacturer's warranties are for up to 20 years. They do outgas hydrogen under charge conditions and must be placed in a secure, ventilated area. The AGM design uses a very fine glass filament matted together and wrapped around the battery plates. This glass mat serves two purposes. Through capillary action, the acid electrolyte is drawn up between the plates with the mat acting as the immobilizing agent. The glass mat is not 100 percent saturated; thus there are small openings between the glass filaments. These openings allow oxygen, which is generated on the positive plate during the final stages of charging to migrate to the negative plate and through chemical reaction, convert back to water, conserving the electrolyte. The GELL uses a different approach by adding silica to the electrolyte. This mixture will form a gell compound once the battery has formed. After set-up, the gell will have many cracks in it. These cracks are essential to allow for the oxygen exchange between the negative and positive plates. Once in contact, the same chemical reaction occurs as in the AGM design.

(b) Lead-antimony batteries are the traditional lead-acid units. Their performance is equivalent to that of the lead-calcium batteries, but they require maintenance every three months and life is only about one half that of the lead-calcium units. To retain their capacity, lead-antimony batteries require monthly equalize charging.

(c) NICAD batteries are the most expensive of the various types. Their advantages lie in small size and weight for a given capacity and excellent high and low temperature properties. Life is long, nearly that of a conventional lead-calcium battery, and a six-month maintenance period is adequate. They do require monthly equalize charging, as well as periodic discharge cycles, to retain their capacity.

(d) All of these batteries, except for the NICAD type, are surprisingly temperature sensitive and should be maintained between 72°F to 82°F for optimum performance and long life. Low temperatures reduce battery capacity and high temperatures shorten life. If batteries are to be exposed to severe temperature swings, the NICAD type should be seriously considered.

h. The magnetic synthesizer is a static electromagnetic (EM) three-phase ac power regenerator. The device, powered from the ac utility line, uses no mechanically moving parts in the generation process, and utilizes no semi-conductor elements in the power path. The output wave form of the device is electromagnetically generated, and is completely isolated and independent of the input in all parameters except two, the phase rotation and the frequency. The output phase rotation of the device is governed by the direction of the input phase rotation, while the output frequency is precisely keyed to the input line frequency. There is no electrical connection between the input and the output of the device. The only power line disturbances not correctable by a magnetic synthesizer are frequency deviations and loss of power, both of which require a UPS to correct. An ideal application for a magnetic synthesizer is in a major urban area where utility networks or loops are fed from multiple substations providing very reliable but otherwise “dirty” power. The improved quality of power results from the synthesis of three-phase 60 hertz voltage wave forms which remain essentially constant in magnitude and shape over a large range of input voltage excursions in both the positive direction (surges) and the negative direction (sags). The device consists solely of saturable iron core reactors and transformers, together with capacitors, and employs the principles of ferro-resonance for its operation.

(1) As long as the core of an inductor is not magnetically saturated, the inductor will support a voltage across the windings. However, as the inductor core approaches saturation, the current through the winding will begin to increase. When the core becomes completely saturated and can absorb no more magnetic flux, tremendous currents will flow through the winding, and the voltage across the winding will approach zero. In essence, the device will go from an open-circuit to a short-circuit.

(2) If the voltage across the saturated reactor is now reversed, the core will begin magnetizing in the other direction and will again act as an open-circuit. The inductor will support this reversed voltage until the core becomes saturated in the opposite direction. At this point, the reversed current increases to a maximum and the voltage decreases to a minimum. In standard 60 hertz non-saturating devices, the core flux is oriented in one direction for 1/120 second; but before it can reach the point where the core cannot absorb any more flux, the voltage is reversed, which begins to orient the core flux in the other direction for the next 1/120 second.

(3) The amount of time for the saturation of a reactor core to take place is measured in volt-seconds. The volt-seconds rating for an inductive reactor depends upon the frequency and the voltage desired to be present across the reactor winding before saturation.

(4) A saturating transformer is inherently a non-linear device. It is this non-linearity which makes it valuable in regulating circuits. In a saturating transformer, as in conventional transformers, production of an output voltage depends upon the changing magnetic flux in the transformer core. But unlike conventional transformers, the saturating transformer is designed for the core to reach saturation after a given number of volt-seconds. Because the flux no longer changes when the core is saturated, there is no voltage output at this time.

(5) The primary waveshape and output power level determining elements of the magnetic synthesizing power conditioner are saturating transformers. In order to obtain the desired outputs from these transformers, energy must be injected into the devices. In the magnetic synthesizer power conditioner, energy is introduced through line chokes into the primary windings of the saturating transformer elements. The line chokes are designed to pass the electrical energy from the input lines, while blocking the waveshape and voltage level information. The chokes act as current sources and buffers for the saturating transformer elements. The primary windings are duplicates of the regulated windings of the secondary. Because the primary windings are wound on top of the secondaries and are isolated from them, there is introduced the ability to reject common-mode noise. The primary-over-secondary arrangement also provides a fail-safe feature. A broken connection at any point will not cause the voltage to rise toward infinity at the load. There is no high-voltage failure mode in this device.

(a) Six interconnected saturating transformers are utilized for power wave form synthesis in the power conditioner. At any particular time during operation, one of these cores is unsaturated while the other five are saturated in directions specified by the interconnection configuration. When the one core finally becomes saturated, the voltage across it collapses and it becomes a conductor. That process causes reversal of the voltage across one of the remaining five cores, which then goes out of its present saturated state and begins building toward saturation in the other direction. When the core reaches saturation in the other direction, it will then reverse the voltage across yet another core.

(b) The sequence of saturation and voltage reversals among the transformers is determined by the transformer interconnection configuration and by the phase sequence of the driving circuit. The process continues as long as the power conditioning device is in operation. During the time that a transformer core is unsaturated, there is voltage present in the transformer interconnecting circuit of the power conditioning device. Therefore, sequencing of the transformers will produce a constant series of voltage pulses on the interconnecting circuit. The parameters of each pulse are determined by the volt-seconds design of the corresponding core.

(c) The three-phase sine waveforms which are produced by the design and interconnection of the transformers in the power synthesizing device contain less than 3 percent THD. Because each of the wave forms is produced by a saturated element, both the shape and amplitude are stable. Thus, the transformer configuration becomes a source which dictates the voltage level and waveshape of the resulting output. Close voltage regulation is maintained and clean waveshape is assured, each independently of the input line conditions.

i. High quality transient voltage surge suppressors (TVSSs) are available to protect ac systems at all distribution voltage levels. The TVSSs have let-through voltages much lower than basic lightning arresters and are designed for facility and sensitive equipment protection. TVSSs are designed to handle much higher speed transients than lightning arresters.

(1) Underwriter's Laboratory (UL) Standard 1449, Standard for Transient Voltage Surge Suppressors, categorizes TVSS into three types: (1) Direct plug-in TVSS devices incorporate integral blades for connection directly to electrical outlets by consumers wherever point-of-use surge protection is desired. (2) Cord connected TVSS devices have a power supply cord terminating in an attachment plug for connection to nearby electrical outlets by consumers, wherever area of use is desired by the end user. (3) Permanently connected TVSS devices are equipped with terminals or leads that are hard wired by qualified personnel into the building's electrical service entrance and distribution system.

(2) UL recently revised UL Standard 1449, Second Edition, August 15, 1996, for permanently connected TVSS devices to increase the test duty cycle a TVSS must pass. The measured limiting voltage test was previously known as the “transient voltage surge test.” This test assigns a suppression voltage rating, or let-through voltage, to a product under test. The first and last test surge current magnitude used to benchmark and measure the TVSS capability has been reduced from 3000 A to 500 A. While the duty cycle part of the test has been reduced in number of impulses from 24 to 20, the current magnitude has been increased from 750 A to 3000 A. The benefit of this change is that the TVSS under test is now subjected to a more strenuous duty cycle test than with the previous version of the test. A wide variety of additional tests have been included in the revised UL 1449, including testing of components (capacitor endurance test), enclosure integrity tests (enclosure impact test, crushing test, mold stress-relief distortion test, mounting hole barrier test, and adequacy of mounting test), as well as manufacturing and production line testing.

3-5. Power distribution systems

Power distribution systems, otherwise called power distribution units (PDUs), moveable power systems or computer power centers, are sometimes confused with load protective equipment. The purpose of a power distribution system is to provide convenience in distributing power to computer system elements, to avoid some electrical contractor expenses, and possibly to obtain a better job, particularly if the contractor is not experienced in computer system installation. Power distribution systems are made by some computer suppliers and independents, but they do not provide any protection against power line disturbances unless specially equipped to do so. However, such a UL listed system should certainly be considered for complex computer installations since it can provide proper wiring and grounding, monitoring of key power system variables, and other features which will assure that good installation practices have been followed.

CHAPTER 4

GROUNDING

4-1. Purpose of grounding

The primary purposes of grounding for circuits, cables, equipment, and systems are to prevent shock hazard, protection of circuits and equipment, and reduction of electromagnetic interference (EMI) due to electromagnetic (EM) field, common ground impedance, or other forms of interference coupling. The various grounding systems used (lightning, power, and/or signal) are integral parts of a facility or system whether they involve vehicles such as automobiles, ships, missiles, or aircraft; buildings; or building complexes. Like other facility components, grounding networks are exposed to the ambient EM environment. This environment includes many sources ranging from incident radio frequency (RF) signals to lightning, and from atmospheric noise to internally generated stray currents.

a. The objective and plan of the facility ground network design should consider all aspects to the degree required for the particular mission of the facility in its environment and in the context of cost-effectiveness. The use of the term facility ground network is intended to be in the collective sense; it includes the power fault protection network, lightning protection network, building or structure (or frame, hull, fuselage skin, etc.) ground, equipment ground, signal ground, instrument ground, data ground, etc. Attempts should be made to integrate the three features of lightning protection, electrical safety, and EMI control.

b. The integration of these features in the design may be difficult because they usually do not fall under the responsibility of the same individual, group, or perhaps company, and they may not even be considered in the same time frame. In the case of a building, lightning protection and power grounding are often decided by an architectural and engineering firm during the structural design phase, and EMI control aspects are left to the electronic equipment engineers for resolution long after the building is finished. When this happens, tradeoffs become difficult. However, the various grounding networks must interface and they all must operate in a common EM environment. To alleviate this situation in future facilities, equipment designers and EMI engineers must be allowed to participate early in the facility design process. For existing structures, those persons responsible for electronic equipment grounding should become thoroughly familiar with the power and lightning-protection ground networks through reviews of drawings, performance of current and voltage measurements, and physical inspections before deciding upon the final signal/equipment grounding networks.

4-2. National electrical code (NEC) requirements for grounding

Requirements for the safe installation of electric conductors and equipment within or on various facilities are contained in National Fire Protection Association (NFPA) 70-2005 and the NEC. The purpose of the NEC is “the practical safeguarding of persons and property from hazards arising from the use of electricity.” The NEC is the most widely used code having been adopted by the majority of the states, counties, municipalities, cities, etc. The federal government, through the Occupation Safety & Health Administration (OSHA) adopted the NEC in 1971. Since this code is universally adopted, it serves as a basis for information technology systems’ equipment complying with the minimum requirements found in the Code.

a. The NEC contains the intent for grounding. The requirements for grounding the process control equipment and distributed control systems are contained in several sections of the NEC. These sections specifically address equipment (enclosures), above 50 volts, below 50 volts, and grounding electrode.

b. The grounding of the electrical system and connection of the electrical system neutral to earth must be connected at only one point to the equipment grounding conductor. Reasons for the electrical system to be grounded are stabilization of the voltage (that is, to keep it from floating above a set reference point), facilitation of clearing phase to enclosures/ground faults, and limitation of lightning and line surges. The NEC calls for bonding the electrical system to the enclosures of (1) conductors and wireways such as conduit, and (2) equipment.

c. Article 250, III, of the NEC addresses the requirements for equipment grounding.

(1) The word “enclosure” is defined in Article 100 as “The case or housing of apparatus, or the fence or walls surrounding an installation to prevent personnel from accidentally contacting energized parts, or to protect the equipment from physical damage.” In Article 250, IV, “Enclosure Grounding” could be confused with the word enclosure as being similar to a raceway, which may be rigid or flexible conduit, wireways, busways, etc. All equipment enclosures will, therefore, be referred to simply as “equipment” as is done in III of Article 250. Although distributed control systems are not mentioned in name, Section 645-15 states that “All exposed noncurrent-carrying metal parts of an information technology system shall be grounded in accordance with Article 250 or shall be double insulated.”

(2) If the equipment is fastened in place or connected by permanent fixed wiring methods, which is not the usual case, then the exposed noncurrent-carrying parts likely to become energized shall be grounded, if within 8 feet vertically or 5 feet horizontally of ground or grounded metal objects and subjected to contact by persons (refer to Section 250-110). It can be inferred from Section 110-26 that concrete, brick, or tile floors are considered as grounded. Since the walls are assumed to be grounded, the floor could also be assumed to be grounded since it touches/attaches to the wall. However, to assure adequate ground protection the floor must be bonded to a known ground. Most IT equipment systems are connected by cord and plug. Although these systems are not mentioned by name, it is accepted practice that the noncurrent-carrying equipment parts be grounded.

d. NEC 250-20(b) addresses the grounding requirements of electrical systems above 50 volts to 1000 volts. The article addresses systems supplying premises wiring and premises wiring systems. It does not address the electrical supply system powering the IT equipment and distributed control systems. The building electrical system can be a grounded, ungrounded, or high impedance (resistance) grounded system. The definition of premises wiring from Article 100-A of the NEC is: “That interior and exterior wiring, including power, lighting, control, and signal circuit wiring together with all of their associated hardware, fittings, and wiring devices, both permanently and temporarily installed, that extends from the service point of utility conductors, or source of power such as a battery, a solar photovoltaic system, or a generator, transformer or converter windings to the outlet(s). Such wiring does not include wiring internal to appliances, fixtures, motors, controllers, motor control centers, and similar equipment.” It is, therefore, prudent to assume that this section does not apply then to anything other than premises and excludes equipment connected by cord and plug.

e. Grounding requirements for electrical systems below 50 volts are addressed in Article 250-20(a). Thus, if IT equipment and distributed control systems were to use electrical systems less than 50 volts ac, and if the conditions covered below apply, the ac system must be grounded.

- (1) If the transformer supply system exceeds 150 volts to ground
- (2) If the transformer's primary system is ungrounded
- (3) When installed as overhead conductors outside of buildings

f. Section 250-30 of the NEC addresses the grounding of separately derived systems. Large information technology equipment systems can have a separately derived system through a delta-wye grounded transformer. This article of the NEC shall apply when an IT system is powered by such a network.

(1) The grounding electrode shall be as near as practicable to and preferable in the same area as the grounding conductor connection to the system. The grounding electrode shall be: (1) the nearest available effectively grounded structural metal member of the structure; or (2) the nearest available effectively grounded metal water pipe; or (3) other electrodes.

(2) There is an exception dealing with transformers rated not more than 1000 VA. A 1000 VA transformer can use the frame, and, therefore, a grounding electrode is not necessary. This exception is stated in Section 250-30(a)(2).

g. The key to one of the problems with IT equipment and distributed control systems is found in III, "Grounding Electrode System," Section 250. This part of the NEC states that all grounding electrodes that are present at each building or structure shall be bonded together to form the ground electrode system (250.52(A)(1) through (A)(6)). This is normally interpreted as meaning that all metallic systems within the structure shall be bonded such that they have a common ground plane. These electrodes consist of metal underground gas piping system, other local metal underground systems or structures, and plate electrodes.

(1) Many control system instruction manuals show rods as the only method of connecting to earth for the electrical system and the IT equipment system. This is probably a carryover from the residential wiring practice, where the items listed as "grounding electrode system" are not available and "made and other electrodes" (rods) must be used.

(2) Section 250-60, "Use of Air Terminals" states that "Air terminal conductors and . . . rods . . . used for grounding air terminals shall not be used in lieu of the made grounding electrodes required by Section 250-52 for grounding wiring systems and equipment."

(3) Section 250-53(B) of the NEC states that "Where more than one electrodes of the type specified in 250.52(A)(5) or (A)(6) are used, each electrode of one grounding system (including that used for air terminals), shall not be less than 1.83 m (6 ft) from any other electrode of another grounding system." Two or more grounding electrodes that are effectively bonded together shall be considered a single grounding electrode system." The isolation between electrical systems, which was sought through separate ground rods, was usually non-existent. The electrical systems were actually tied together through the "sphere of influence." The radius of the sphere of influence of a driven rod is equal to the rod's depth. If a 10-foot rod is driven into the earth, everything within a radius of 10 feet will be under the influence of the 10-foot deep rod. The average resistance between a second rod driven within a sphere whose radius is 10 feet

and which is centered at the top of the first rod will be negligible. They would be considered as being connected together, assuming average earth conditions.

h. The authority having jurisdiction of enforcement of the NEC will have the responsibility for making interpretations of the rules, for deciding upon the approval of equipment and materials, and for granting special permission contemplated in a number of the rules (Section 90-4). If the installation complies with and exceeds the NEC requirements, both stated and inferred, no problems should be encountered in receiving approval for the installation. This will be true if all the electrical systems, grounding systems, equipment enclosures, etc., are all connected and bonded together.

4-3. System configurations

Electrical systems can encompass one item or several. A system may represent a small self-contained electronic circuit totally within the confines of a case, cabinet, rack, or it may be an extended collection of equipment racks or consoles distributed over a wide geographical area. The grounding requirements and procedures will be markedly different for these different types of systems. One way of distinguishing between different types of systems is to examine the manner by which power is obtained and how the equipment elements are interconnected with each other and with other systems. Based on these two considerations, systems may be identified as isolated, clustered, distributed, multiple-distributed, or central with extensions.

a. An isolated system is one in which all functions are accomplished with one equipment enclosure. An isolated system should not be confused with a floating system, which has no external ground. Some isolated systems may be floating while others must be grounded.

(1) Only a single power source is associated with an isolated system. (Single power source means one battery pack, one branch circuit supply, etc.). In addition, only one ground connection (to structure, to earth, to hull, etc.) for the entire system is needed for personnel protection or lightning protection, or no facility ground connection at all is required. No conductors except the power cord and the appropriate ground exists because no interfaces (power or signal) with other equipment or devices, which are grounded, are present or needed. Common examples of isolated systems are hand-held calculators, desktop computers (off line), home-type radios, television receivers, etc.

(2) Grounding requirements for isolated systems are illustrated by figures 4-1 and 4-2. They typically include a third wire ground if powered with single-phase ac or a ground-cable run with the power conductors if multiphase ac is involved. Double insulated systems as defined in NEC Article 250-114 are not required to have a third ground wire. Battery driven systems usually do not require any grounding, but the system should be isolated. It is important that isolated systems are not located near lightning down conductors, or near other grounded metal objects, and in areas where very high RF voltages may appear on equipment cases. The internal signal grounding requirements of the isolated system are those determined by the designer as necessary for proper self operation.

b. A clustered system as shown in figure 4-3 is characterized as having multiple elements, equipment racks, or consoles located in a central area. Typical clustered systems include minicomputers, component stereo systems, medium scale data processors, and multi-element word processors.

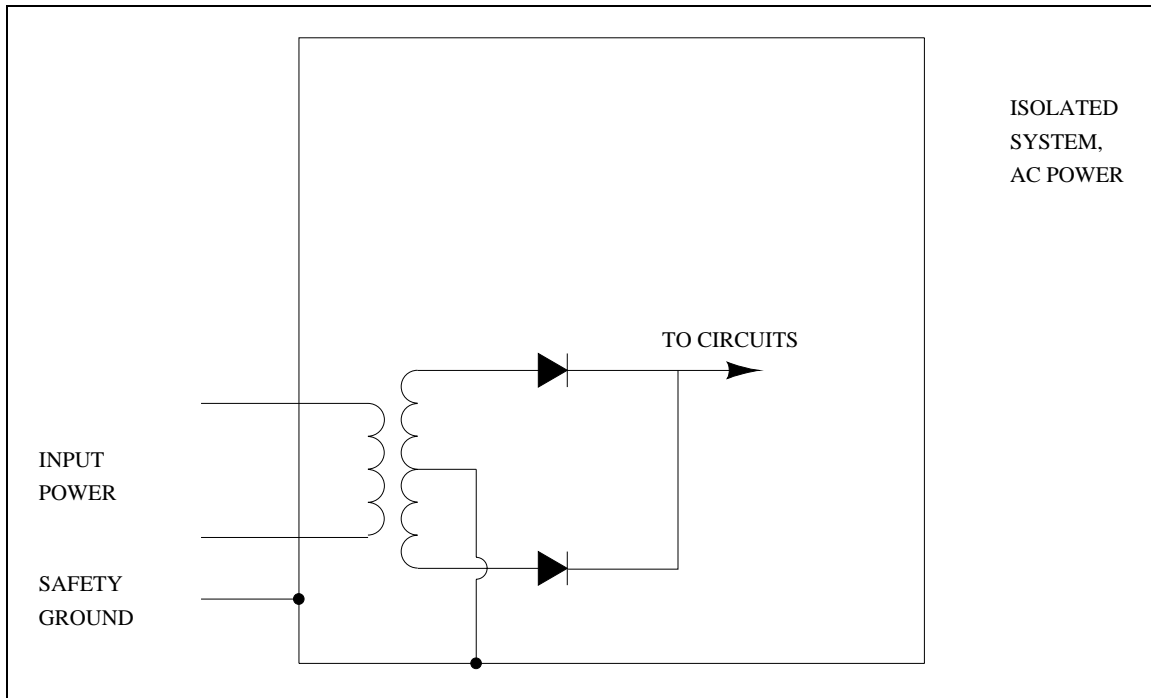

Figure 4-1. Minimum grounding requirements for ac powered isolated system

(1) A distinguishing feature of a clustered system is that it utilizes one common power source, e.g., a battery or a single ac power connection. There are likely to be multiple interconnecting cables (signal, control, and power) between the members of the system but not with any other system. A clustered system only needs one facility structure ground tie to realize personnel safety and lightning protection requirements.

(2) Grounding for a clustered system requires that one connection be made to structural ground as illustrated by figure 4-4. If the power supplied is single-phase ac, the third wire ground provides this connection. If the power supply is three-phase ac, (according to Paragraph 250-122 in the NEC) a supplemental ground conductor shall be installed. It shall be sized in accordance with Section 250-122 and Tables 250-66 and 250-122 of the NEC. Battery powered systems should have one ground connection to the structure. The signal ground referencing scheme used between the elements of the system should reflect the particular signal characteristics (frequency, amplitude, etc.) of the various pieces of equipment. This scheme may be single-phase or multiple-point.

(a) If a multiple-point scheme is used, the signal ground may be realized with cable shields, auxiliary conductors, or a wire grid or metal sheet under or above the array of equipment. In a benign (quiet) EM environment, signal grounding with cable shields or auxiliary conductors between the interconnected pieces is acceptable. In high level, multi-signal environments, this type of grounding scheme should be avoided because of the antenna pickup effects of the multiple conductors. Signals coupling to the ground conductors produce common-mode voltages between various source-load pairs and raise the threat of interference. A better method of

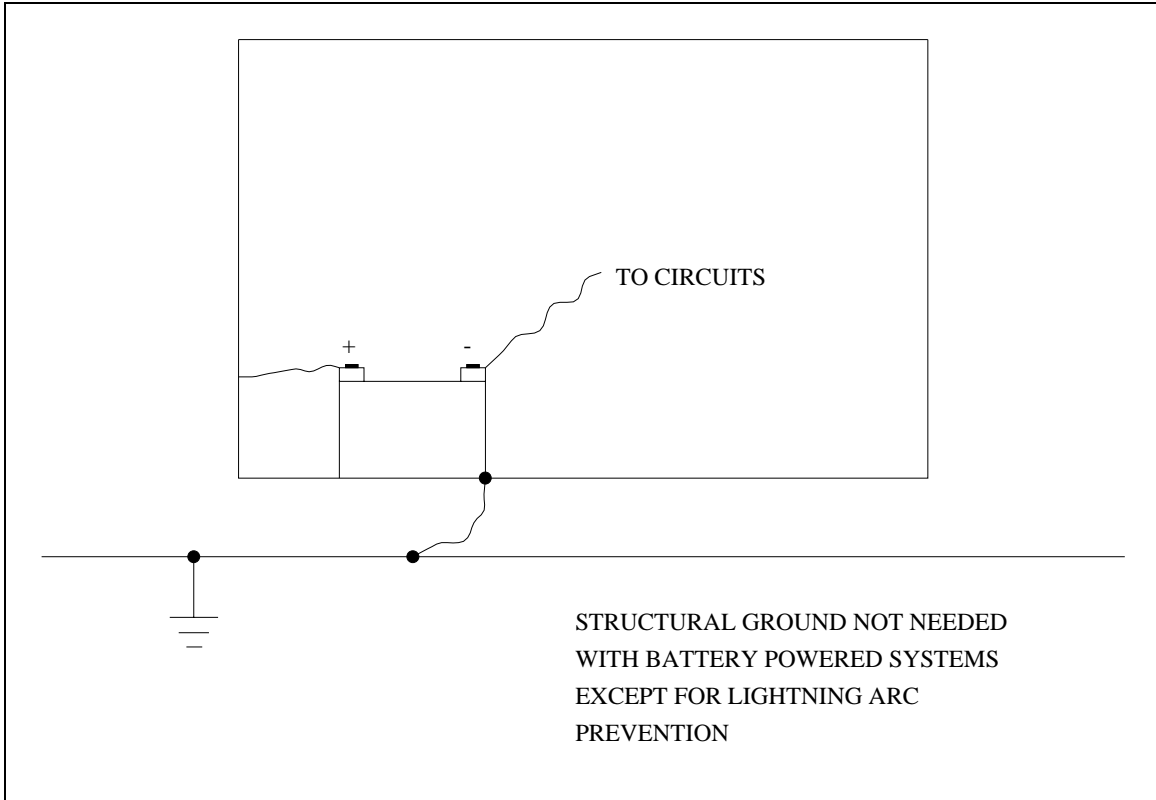

Figure 4-2. Minimum grounding requirements for battery powered isolated system

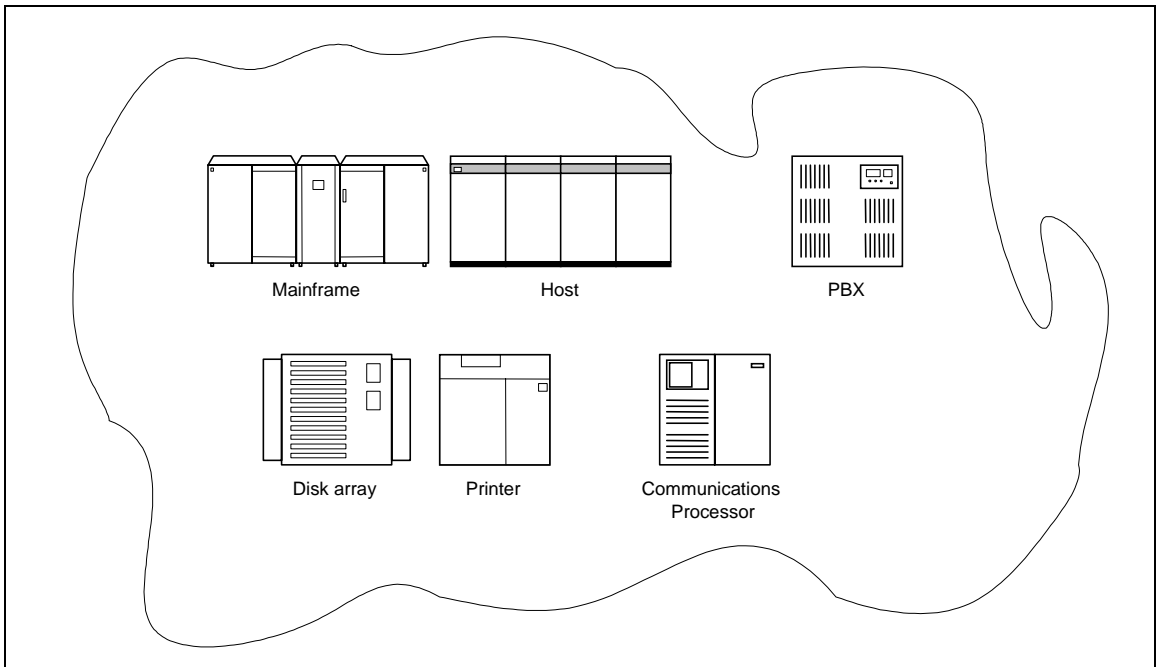

Figure 4-3. Clustered system

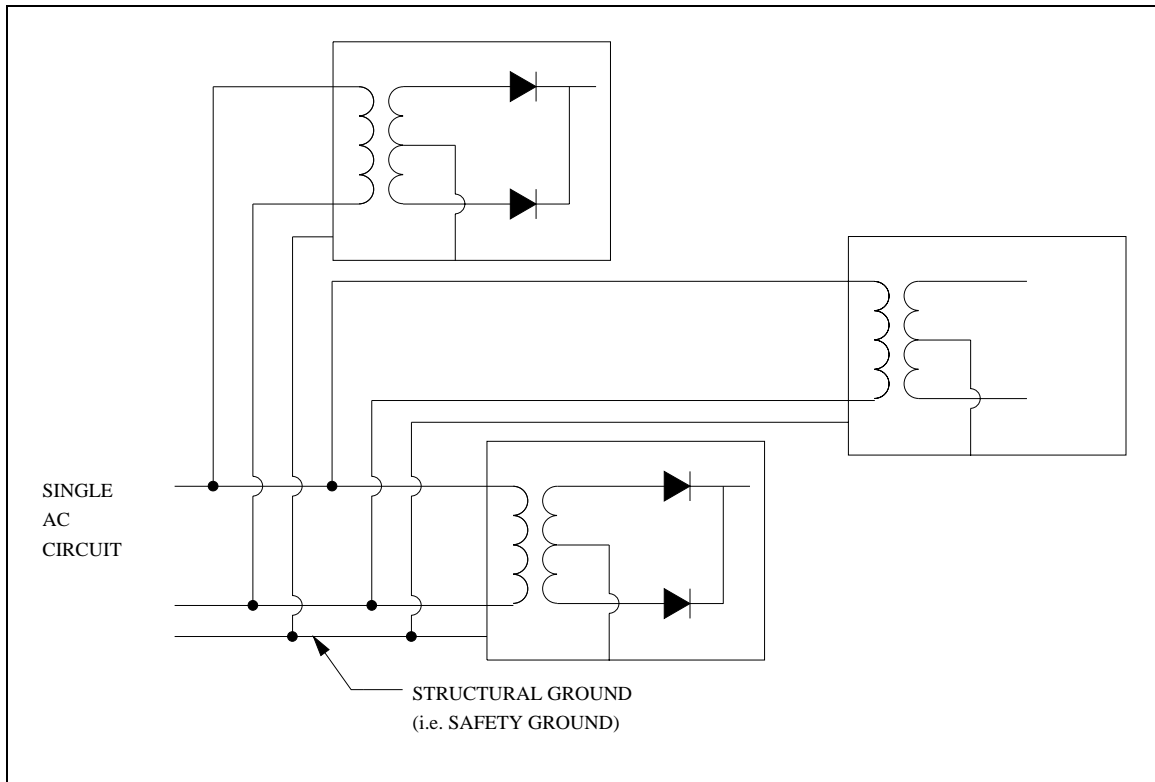

Figure 4-4. Basic grounding of a clustered system

grounding should provide broad metal paths between the pieces of equipment of the system. Overhead or underfloor ductwork, cable trays, and wire channels can frequently provide the necessary signal grounding and fault protection network for a clustered system. The best approach, and the one recommended for use in high level RF environments, will use a close-mesh wire grid or a solid metal sheet for mounting the various pieces of equipment of the system.

(b) In extremely severe environments as in the vicinity of a transmitter, the solid sheet is preferred over the grid. Each cabinet is carefully bonded to this grid or sheet. All interconnecting signal leads, power buses, etc., should be routed inside enclosures and beneath the ground plane, preferably in conduit or in raceways. Note that the evolution from the poorest to the best approach is aimed at rendering the system and its cables successively less effective as a pick-up antenna for radiated RF energy, particularly in the broadcast, high frequency, very high frequency, and ultra high frequency bands.

c. A distributed system is one in which major elements are physically separated in a way that requires equipment to be variously fed from different power outlets, branch circuits, different phases of the line, or perhaps even different transformer banks.

(1) In a distributed system, separate safety and lightning protection grounds to the facility (vehicle) structure (frame) are required. Another common characteristic of a distributed system is that multiple conductor lengths are likely to be greater than 1/10 of a wavelength at frequencies where an interference threat exists. Examples of distributed systems include industrial process control, environmental monitoring and control, communications switching, large main frame computer nets and affiliated IT equipment systems.

(2) Effective grounding of distributed systems to achieve the required safety and lightning protection for equipment and personnel, while minimizing noise and EMI, requires careful application. To describe a stereotyped network or to list a set of rules is not considered prudent. General guidelines follow.

(a) If the system is ac powered, consider each major element (consisting of one or more types of equipment essentially located at a particular location) as either an isolated or clustered system, as appropriate. Proceed to ground each major element. Each and every signal port on these isolated or clustered subsystems that must interface with other portions of the total system, i.e., other subsystems, should be viewed as interfacing with a noisy world. As such, the techniques for controlling unwanted coupling of radiated and conducted interference into the signal paths must be fully employed. Obviously, discretion will be necessary. There will be situations, depending upon the properties of the signal being transmitted from terminal to terminal, the characteristics of the signal path, and the nature of the EM environment, in which no additional protective measures are required. In general, adequate isolation must be provided between the external (to the system) conducted and radiated noise environment and the signal path.

(b) Common battery distributed systems present a particular challenge. Such systems are commonly found on aircraft where the fuselage is used for dc power return. The use of the equipment rack, structure, hull, or fuselage for the power return path means that the structure becomes the circuit reference. Therefore, voltage differentials between various points in the structure appear in series with any single ended, unbalanced signal paths. Again, adequate rejection against such conducted interference must be obtained.

(3) Multiple distributed systems are similar to that of a distributed system except that there are usually several systems contained and operating in the same general area. Typically, the multiple systems share the primary power sources. A distinguishing feature of multiple distributed systems is that they typically run a high risk of interfering with each other and are susceptible to interference from facility noise and the external environment. Thus, in addition to having grounding requirements like those discussed for distributed systems, additional shielding and filtering requirements are necessary to minimize intersystem interference.

d. A central system with extensions is illustrated in figure 4-5. It is distinguished from an isolated or clustered system in that integral elements of the systems extend out from the central portion at long physical and electrical distances. This system is distinguished from a distributed system in that the extended elements obtain their power from the central element. Connections to a power source are not made anywhere except at the main element. An example of this type of system is an industrial process controller with sensors and actuators located remotely from the data logger or controller.

(1) The central or primary element of this type of system should be founded as though it were a clustered or isolated system. Depending upon the operating frequency ranges and signal levels of the extension elements and the characteristics of the EM environment, a single-point tree or star grounding scheme may be used or a multiple-point scheme may be used.

(2) It is likely that most systems of the central-with-extensions configuration will involve relatively low frequency (audio or below) with operating bandwidths encompassing the power frequencies. If this is the situation, a single-point tree is recommended. The ground mode would be at the central element with one connection (the safety ground) made to the structure. Extended elements should be floated or balanced. Twisted pair or balanced signal transmission-line

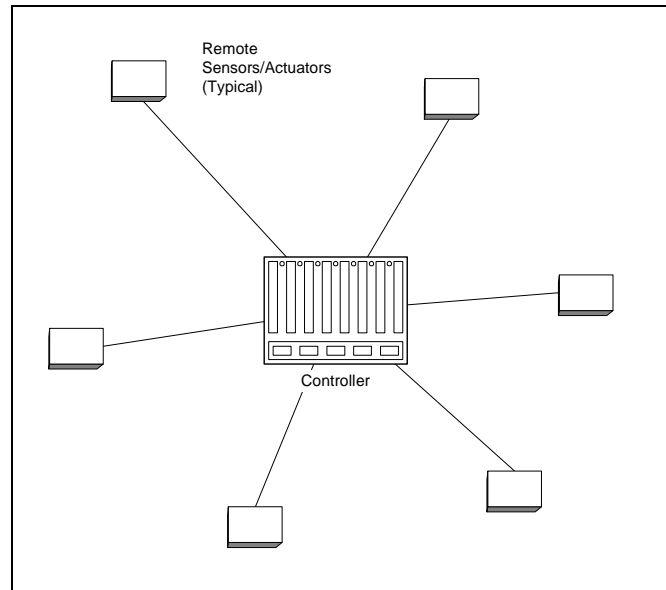

Figure 4-5. Central-with-extensions system

conductors should be used between the central element and the extended elements. If radiated coupling proves to be a problem, the extended elements should be configured, if at all possible, so that the shields (as on coax, for example) from the central element can be continued to enclose the extended elements.

4-4. Ground configurations

a. Single-point grounding means connecting one point (either the source or load end) of the signal return side of the energy transfer loop to ground. There are many applications, which require single-point grounding. Although definitely advantageous in many situations, in a multi-equipment system or facility a single-point ground system can be very difficult to implement and maintain as a true single-point ground system.

b. Multiple-point ground attempts to realize an adequately low ground plane impedance, i.e., minimize ground reference voltage differentials, is the basis of multiple-point grounding. In multiple-point grounding, the source and load end of every energy (signal) transfer pair is connected to a ground plane (chassis, equipment cabinet, structural frame, printed circuit board, etc.) by the shortest electrical path. The ground plane is also interconnected by the largest feasible number of parallel paths. Ideally, the ground plane would consist of a solid metal mass of lowest possible resistance.

c. A signal ground is necessary for RF equipment and circuits which frequently utilize the chassis, cabinet, or large unetched areas on printed circuit boards as ground planes for the signals of primary interest. Large, common areas are effective RF signal grounds because wide metal paths exhibit lower inductance, and thus lower impedance, than do round wires or narrow rods. To retain the ground plane effectiveness, paths serving as individual component, device, or network grounds must be short to minimize the circuit-relative impedance; thus, the overall ground must be brought to the component, device, or network. RF interfaces (input and output signal ports) are typically unbalanced and thus cable references, or signal grounds, must be the same as the chassis or cabinet ground.

d. The control of ground plane impedance is important in ensuring a noise-free system. Interference between circuits and systems always exists between ground conductors.

(1) Grounding conductors and paths exhibit inductive, capacitive, and resistive properties. Having such properties means that grounding conductors and paths rarely provide the zero impedance, or equipotential, reference plane which is sought for the grounding of signals. Any unwanted signals, whether they are power or microwaves, pose a threat of interference to desired signals whose circuits are referenced to the network.

(2) If both source and load ends of a circuit are connected to a noisy ground reference, a possibility exists for interference. Obviously, if the voltage differential between the source and the load is reduced, the interference threat is reduced.

(3) Reduction of interference can be done through lowering the impedance of the path through which the interference currents (and, frequently, the desired signal currents) are flowing.

(4) Ground noise problems can frequently be solved by providing more ground paths through the bonding of all metallic members of an equipment cabinet, or of a structure, together with low impedance interconnections. The technique, if thoroughly applied throughout a facility, can be very effective in reducing ground system (plane) impedance. The use of massive ground-return conductors, grounding sheets, or large area plates are frequently helpful.

e. In situations where single-point grounding is required at RF frequencies, capacitive grounding can be used. This is referred to as frequency-selective grounding. The inverse situation can also be employed where an inductance is used to achieve a dc and low frequency ground (e.g., for safety) and approximate an open circuit at RF. Parasitic effects can render capacitive and inductive grounding highly unpredictable and should be used only under unusual conditions and with a great deal of care to assure that the overall interference problem is not aggravated.

4-5. Grounding for fault protection

Fault protection is an integral part of ground network design. Frequently, signal grounds are common with fault protection paths, particularly where structural elements of a building are involved. Because traditional practices and personnel and structural protection requirements strongly favor that priority be placed on fault protection needs over EMI needs, it is likely that signal ground networks must be designed to be compatible with these networks. Occasionally, requirements of fault protection will force compromises in the signal ground design and implementation. The following discussion presents an overview of the principles of design behind fault protection systems.

a. One primary reason for grounding is to prevent electric shock in the event of a circuit fault. Electric shock occurs when the human body becomes a part of an electric circuit. It most commonly occurs when people come in contact with energized devices or circuits while touching a grounded object or while standing on a damp floor. The effects of an electric current on the body are principally determined by the magnitude of current and duration of the shock. Current is determined by the open circuit voltage of the source and total path resistance including internal source resistance and human body resistance.

(1) In power circuits, internal source resistance is usually negligible in comparison with that of the body. In such cases, the voltage level, V , is the important factor in determining if a

shock hazard exists. At commercial frequencies of 50 to 60 hertz and voltages of 120 to 140 volts, the contact resistance of the body primarily determines the current through the body. This resistance may decrease by as much as a factor of 100 between a completely dry condition and a wet condition. For estimation purposes, the resistance of the skin is usually somewhere between 500 and 1500 ohms.

(2) An electric current through the body can produce varying effects including death, depending upon the magnitude of current. For example, the perception current is the smallest current that might cause an unexpected involuntary reaction and produce an accident as a secondary effect. Shock currents greater than the reaction current produce an increasingly severe muscular reaction. Above a certain level, the shock victim becomes unable to release the conductor. The maximum current at which a person can still release the conductor by using the muscles directly stimulated by that current is called the let-go current. Shock currents above the let-go level can begin to cause chest muscles to contract and breathing to stop. If the current is interrupted quickly enough breathing will resume. At a still higher level, electric shock currents can cause an effect on the heart called ventricular fibrillation. Under this condition, usually there is a stoppage of heart action. Various current levels for 60 hertz and dc are summarized in table 4-1. At frequencies above 300 hertz, the current levels required to produce the above effects begin to increase due to skin effort. For example, the perception current is approximately 100 milliamperes at 70 kilohertz (kHz). Above 100-200 kHz, the sensation of shock changes from tingling to heat. It is believed that heat or burns are the only effects of shock above these frequencies.

b. To protect people from inadvertent exposure to hazardous voltages, all exposed metallic elements should be connected to ground. In this sense ground usually means other exposed equipment, metal members of the building, plumbing fixtures, and any other metallic structures likely to be at a different (hazardous) potential in the event of a fault.

(1) If accidental contact occurs between energized conductors and chassis, frame, or cabinet through human error, insulation failure or component failure, a direct low resistance path

Table 4-1. Summary of the effects of shock

<u>Alternating Current (60 Hertz)</u> (milliamperes)	<u>Direct Current</u> (milliamperes)	<u>Effects</u> (milliamperes)
0.5-1	0-4	Perception
1-3	4-15	Surprise (reactor current)
3-21	15-80	Reflex action (let-go current)
21-40	80-160	Muscular inhibition
40-100	160-300	Respiratory block
Over 100	Over 300	Usually fatal

exists between the fault and the energy source (usually a transformer) which causes fuses to blow or breakers to trip and thus quickly remove the hazard.

(2) The dependence of shock effects upon frequency suggests that the relative danger from electric shock is related to the duration of exposure so that one objective of the fault protection system (network) is to reduce the time of exposure to a minimum. Another reason for achieving rapid clearance is to limit temperature rise in the faulted conductor and thus minimize a potential fire hazard.

c. Fault protection design is normally governed by the NEC and other established industry standards. The NEC is issued by the NFPA as NFPA 70 and is updated every three years. This code has been adopted by the American National Standards Institute (ANSI) as ANSI/NFPA 70 and it is rapidly becoming universally accepted. It has become, in effect, a Federal Standard with its incorporation into the OSHA requirements.

(1) When viewed from the perspective of EMI and noise control, it should be remembered that the primary objectives of the NEC are fire and shock hazard protection and not the achievement of EM compatibility. However, this does not mean that practices of the NEC are necessarily in opposition to good EMI practices. It does mean that the NEC standards must be met in any equipment or system design and installation and, therefore, its requirements must be thoroughly understood while implementing any EMI grounding system. Another thing to realize is that simply conforming to the NEC does not assure a noise-free system; generally other measures also must be employed to achieve the desired level of total system (equipment, facility, and environment) compatibility.

(2) Article 250 of the NEC sets forth the general grounding requirements for electrical wiring in a structure. Present requirements of the NEC specify that the ground lead (green wire), in a single-phase ac power distribution system, must be one of three leads. The other two leads comprise the hot lead (black wire) and the neutral lead (white wire). The ground lead is a safety conductor designed to carry current only in the event of a fault. The hot lead is connected to the high side of the secondary of the distribution transformer. For fault protection, the NEC specifies that the neutral be grounded at the service disconnecting means (main breaker). The safety ground (green wire) is grounded at that point as shown in figure 4-6. All exposed metallic elements of electrical and electronic equipment are connected to this ground with the green wire.

(3) Grounding of a three-phase wye power distribution system is done similarly to the single-phase system. The connections for a typical system are shown in figure 4-7. The neutral lead, as in single-phase systems, is grounded for fault protection at the service disconnecting means. The NEC specifies that the neutral should never be grounded at any point on the load side of the service entrance on either single-phase or three-phase systems.

(4) Figure 4-8 illustrates two correctly wired branch circuits. In the separate branch circuit, two pieces of equipment are energized from separate branch circuits. Minimum power-related voltages exist between the equipment cabinets A and B. Thus, potential interference currents in the interconnecting ground path (provided, for example, by a ground bus, cable shield, etc.) are small. The common branch circuit in figure 4-8 shows both pieces of equipment sharing a common-branch circuit, as in the same room, for example.

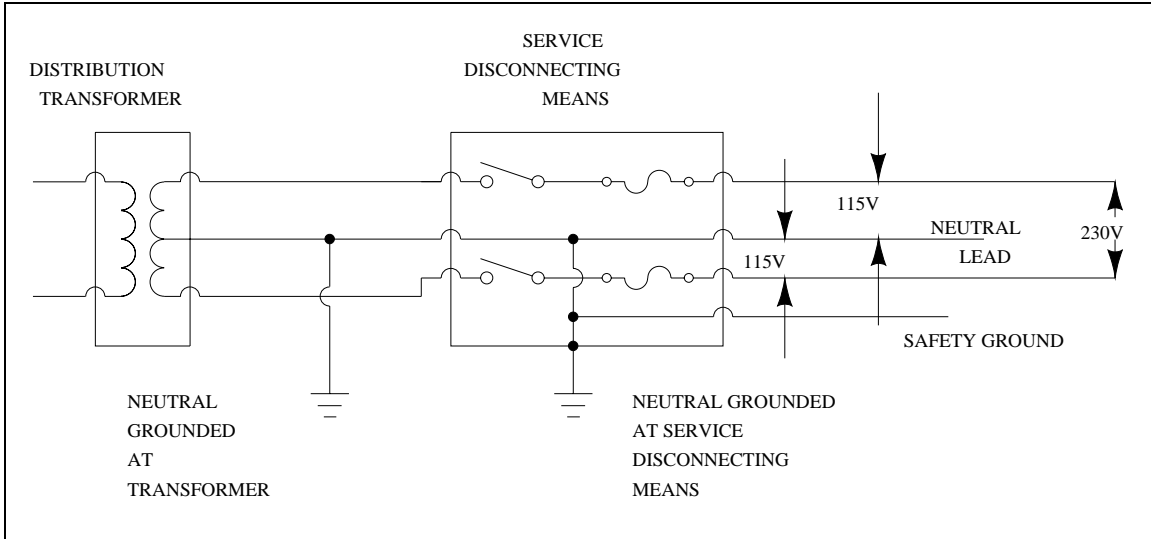

Figure 4-6. Single phase 115/230 Vac power ground connections

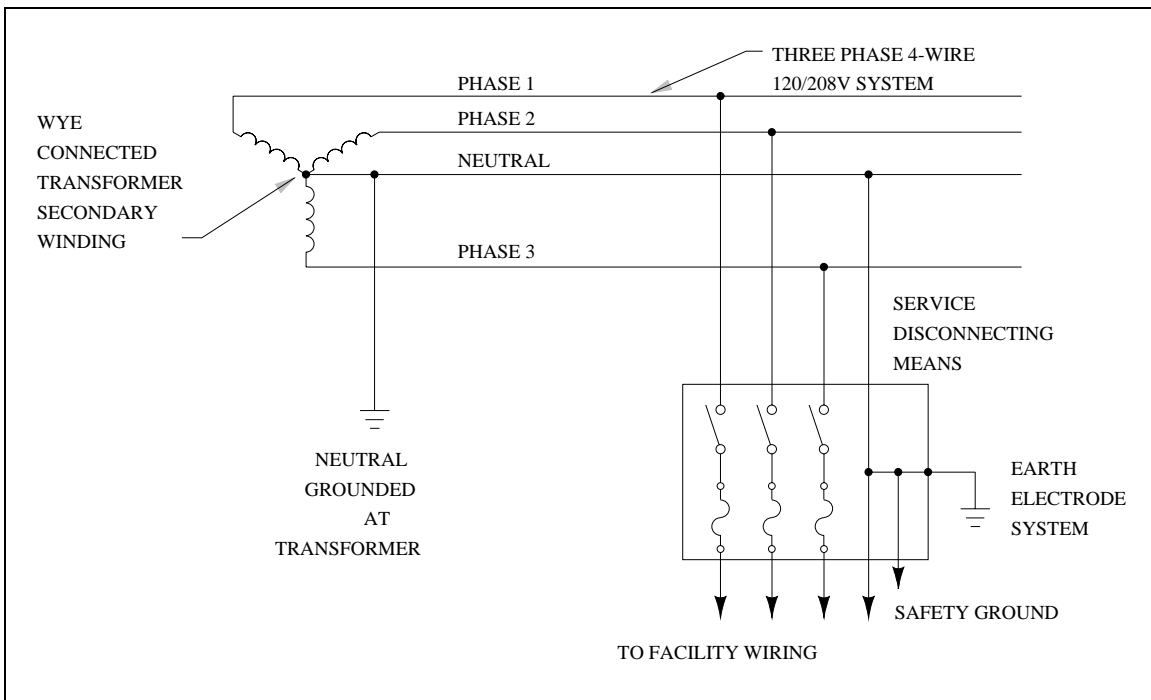

Figure 4-7. Three phase 120/208 Vac power system ground connections

(5) Figure 4-9 shows the effects of improper wiring.

(a) The hot neutral reversed condition is that of reversal of the hot (black) and neutral (white) conductors. This can result in a short circuit condition. Although a violation of the NEC, it does not automatically produce stray or return currents in the safety wire (or equipment cabinet/conduit system).

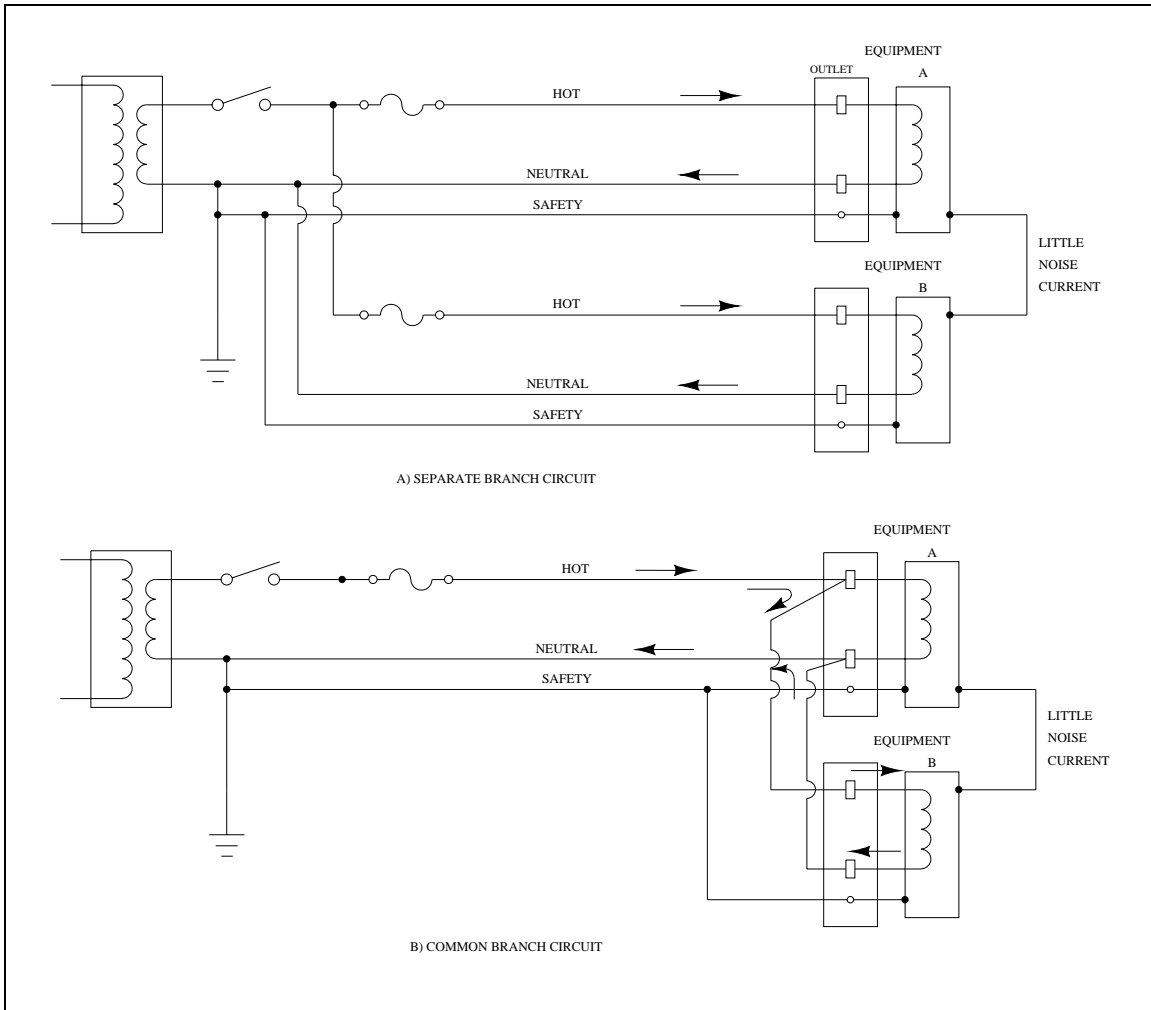

Figure 4-8. Properly wired ac distribution circuits for minimum ground noise

(b) The other conditions of figure 4-9 represent the most likely problems and are the most troublesome from the standpoint of stray noise. Interchange of the neutral and ground conductors frequently exists because no short circuit is produced and the condition may go undetected. The full load current of terminating equipment, however, returns through the safety wire/conduit/cabinet ground system. The resultant common-mode voltages and currents pose a severe threat to interconnecting circuits between equipment A and B. The condition of neutral safety interchanged, separate branch circuit is the most troublesome from the standpoint of power frequency common-mode noise because of the higher voltage drop developed by the return current traveling through the longer path.

(c) These conditions are the sources of many facility ground noise problems. Improperly grounded neutrals can occur in a piece of terminating equipment or can be the result of improper wiring at an outlet, junction box, or switch panel. (The most common cause is improper wiring.) If the neutral is grounded at any point except at the service disconnect, part (if not most) of the load current returns from the load back through conduit, raceways, equipment

cables (including coax and other cable shields), and structural support members. Voltage drops associated with this return load current appear as common-mode noise sources between

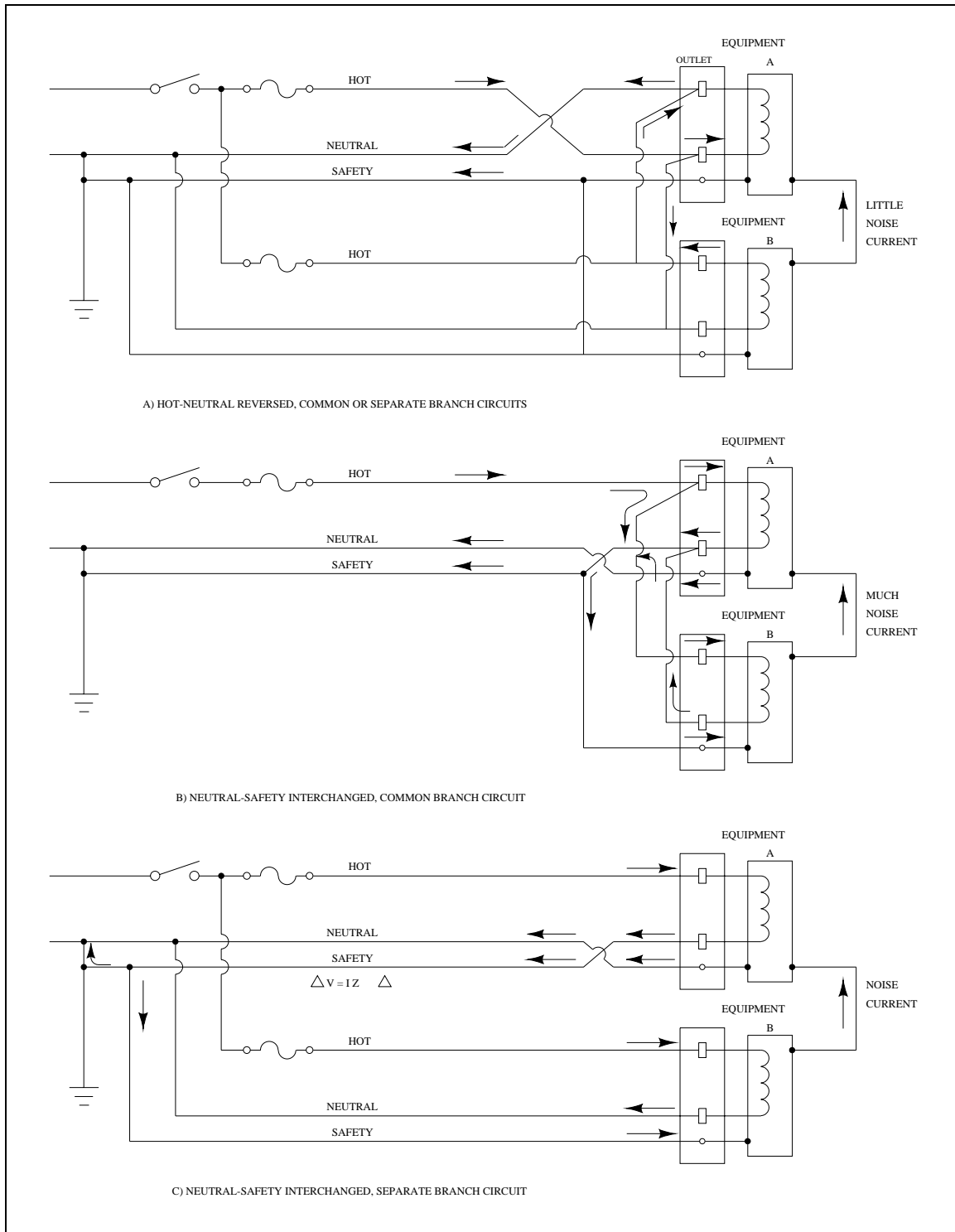

Figure 4-9. Noise problems resulting from improper wiring

separately located equipment, as illustrated. If this equipment must be interconnected with signal paths, appropriate common-mode rejection measures must be employed in the signal paths.

4-6. IT equipment grounding

The primary objective of grounding for IT equipment is to minimize electronic noise that would adversely affect the output signals of the equipment. The power-distribution system for IT equipment rooms is usually designed by an electrical consultant and installed by an electrical contractor to insure maximum reliability. Grounding provisions provide personnel safety equal to or exceeding the requirements of the NEC. The information technology equipment is usually designed and installed by IT equipment manufacturing companies or their contractors, in cooperation with the user-purchaser. The IT equipment room installation often includes a raised floor, with power to IT equipment, interconnections, cooling-air distribution, and a fire-extinguishing system all located under the floor. This is where the usual interfaces are accomplished and where problems frequently occur between the IT equipment installation and the electrical distribution system powering the IT equipment. Grounding methods have been developed to minimize noise, sometimes isolating the IT equipment grounding system from the rest of the building grounding system. However, some of these methods are violations of the NEC grounding requirements and may be unsafe.

a. To prevent electrical noise from affecting IT equipment, two entirely different and separate grounding systems are required.

(1) First, the power distribution system must be grounded in accordance with NEC requirements for safety, and in addition the 60 hertz power system grounding must be so designed that it will minimize noise pickup that can affect the IT equipment operation.

(2) Second, the IT equipment and enclosures must be connected to a reference grounding system for high-frequency noise. This high-frequency protection is in no way related to system grounding. In fact, the high-frequency reference will work whether or not it is grounded to the system ground. However, since it consists of exposed, metallic noncurrent-carrying parts that could accidentally become energized, it must be grounded, as required by NEC Section 250-96.

(3) Once it is recognized that proper IT equipment grounding requires both a 60 hertz and a high-frequency grounding system, that electrical safety requires that the two systems be bonded together, and that each system can be examined separately, then it can be determined how to bond them so they are compatible.

b. The grounding of IT equipment is done in accordance with NEC Article 645, Information Technology Equipment.

(1) IT equipment grounding, like all other electrical equipment grounding, has only one purpose -- safety. The grounding performs two functions. First, it ties all equipment together with low-impedance conductors so all equipment is at the same potential. It also bonds that system to the grounding-electrode system so that the potential is that of the earth. If the grounding is done in accordance with the NEC, there should not be an unsafe difference in potential between any two pieces of exposed noncurrent-carrying metal or from any noncurrent-carrying metal to ground, even under fault conditions. Second, the equipment grounding provides a safe, low-impedance return path for ground-fault currents to permit overcurrent devices to clear the fault quickly and thus minimize damage.

(2) Where the power system supplying the IT equipment has a grounded conductor (which is usually the case, since most IT equipment use a 208Y/120V power supply with a grounded neutral), that conductor must be grounded in accordance with Article 250. This is frequently a source of confusion and conflict when the IT equipment is supplied from a separately derived source such as a dedicated transformer or an uninterruptible power supply (UPS) or motor-generator (M-G) set. The NEC requirements are intended to ensure a safe installation and are not concerned with whether or not the system works properly so long as it is safe. It is important to keep this in mind. It is necessary to conform to the code and at the same time design and install an equipment grounding system that will permit the IT equipment to operate with a minimum of noise problems and data-handling errors.

(3) In a mistaken effort to isolate the IT equipment system from the rest of the building power system, many systems have been grounded to a ground rod or buried ring around the building but not connected to the building grounding system and grounding electrode. This isolation has often been achieved by using many makeshift devices to keep the IT equipment insulated from the metallic parts of the distribution system.

(4) Power-supply conduits have been insulated from IT equipment cabinets with polyvinyl chloride (PVC) conduit fittings or even plumbing fittings. Conduit runs have been ended before reaching the equipment cabinet and the conductors run the remaining distance exposed. Green-insulated grounding conductors have been run separately from the circuit conductors and to a separate ground point. Ground pins have been cut off plugs and the green wire left floating. Flexible cords, without grounds, have been used to supply the IT equipment, and so on.

(5) All these schemes are unsafe, because there is no low-impedance return path for fault current and no assurance of equal potential between the equipment and other grounded metal. They violate many sections and every intent of the NEC. Finally, they often result in more equipment noise than proper grounding would produce, because the multiple ground points can have differences in potential between them, causing circulating ground currents and false data inputs or processing.

(6) IT equipment grounding must be done in accordance with NEC Article 250 and consist of IT equipment grounding and power-system grounding. All equipment grounding essentially requires that exposed noncurrent-carrying metal parts be connected by equipment grounding conductors to the grounding electrode at the electric service equipment, or at the power source if power is obtained from a separately derived system. The equipment grounding conductors must run with or enclose the circuit conductors and may be one or more of a combination of the types listed in NEC Section 250-118. These include a bare or insulated conductor, rigid or intermediate metal conduit or electrical metallic tubing, flexible metal conduit approved for the purpose; the armor of Type AC armored cable; cable trays; and other raceways specifically approved for grounding. An insulated grounding conductor must have an outer finish that is green or green with a yellow stripe. The grounding path must be permanent and continuous, and conductors must be sized and installed in full compliance with the many other applicable code requirements.

(7) IT equipment grounding will comply with the code and will be safe if it meets these requirements. However, several additional provisions are necessary if the IT equipment installation is to operate with minimum noise problems from the ground system. If IT equipment is installed in the same way as most other electrical equipment, the grounding may create many multiple grounding paths. The grounding conductors are run with the power conductors from the source to each piece of equipment, but there are also many pieces of equipment fed from other equipment, and many other metallic interconnections between the grounded metal enclosures of

various units. This can be perfectly safe, and in accordance with the code for equipment grounding, but the multiple points of grounding can have slight differences in potential, causing small ground currents to flow, especially under transient conditions. These ground currents appear as noise to the data-processing equipment and can cause errors in computation or component failures. This arrangement produces “ground loops” – multiple paths for the circulation of ground currents.

(8) By modifying the grounding these ground loops can be eliminated. Each piece of equipment is fed separately and radially from the source and is grounded (by means of the metallic raceway, green-wire ground, and any other grounding conductors) to a single IT equipment ground point (G) at the source or distribution point. This radial grounding eliminates any ground loops. In addition, each piece of equipment is connected by the shortest possible connection to the reference grid. While these connections seem to create multiple ground loops, as explained earlier, all points on this reference grid are at the same potential, not only at the power frequency of 60 hertz, but also at much higher frequencies, so no currents will circulate. One point on the reference grid must also be tied to the IT equipment ground point to put it at the same ground potential as all other equipment.

(9) A radial installation made as shown to a single ground point can comply in all ways with the NEC, can be entirely safe, and at the same time can be as free as possible from equipment noise problems originating from the grounding system.

(10) Another point of confusion in IT equipment grounding is the selection of the proper grounding electrode to which the IT equipment grounding system must be connected. A frequent error of IT equipment manufacturers is to request a grounding electrode separate from and not connected to the power system electrode – a separate ground rod or ground ring. This is not only unsafe and a code violation; because of differing ground potentials, it can also be a source of, rather than a cure for, IT equipment noise problems.

(a) The proper grounding electrode is clearly spelled out in Article 250 of the code. Where the building service is the source of supply, the grounding electrode must be one or more of those types listed in Section 250-50, to which the grounded circuit conductor (neutral) must also be connected. There is little confusion on this point. However, large IT equipment installations are frequently supplied from a separately derived system rather than directly from the building service. This is done to isolate the IT equipment supply from the other building power systems, and often to condition the IT equipment power to make it more reliable and compatible with IT equipment requirements.

(b) The separately derived system may be a transformer, a computer power center, a M-G set, a synthesizer, or a UPS inverter. In all such cases, the required grounding electrode must be as near as possible to the source of power, the separately derived system (Section 250-30). The grounded conductor, or neutral, of the separately derived system and all equipment grounding conductors must be connected to this grounding electrode, not the one at the building service. A connection may also be made back to the service grounding electrode through the metallic raceway system; but this is neither required by code nor necessary for safety. The reason for this is that any fault currents that flow in the separately derived system must have a low-impedance path back to their source - the separate system source, not the building service.

(c) For separately derived systems, the preferred grounding electrode is the nearest effectively grounded metal structural building steel, or the nearest effectively grounded metal water pipe. If neither of these is available, other electrodes as listed in Section 250-50 may be

used. We have seen installations with grounding connections run several hundred feet back to the service ground from a IT equipment transformer secondary, when the connection could have been and should have been made to the steel building column only a few feet away.

(d) Ground the IT equipment radially to a single ground point, tie it to a high-frequency reference grid, and ground this grid to the same IT equipment ground point. Ground the IT equipment ground point to the proper grounding electrode, and an IT equipment grounding system that is electrically safe and meets all code requirements, will be essentially free of ground-caused IT equipment noise and problems.

c. IT equipment input, process, and output data at tremendous rates which are constantly increasing. Typical IT equipment clocks that control the data transfer into, within, and out of the equipment operate at very high frequencies [upwards of 1 gigahertz (GHz)]. These are radio frequencies, and IT equipment is sensitive to these frequencies. The wiring can act as a receiving antenna and can respond to external RF signals that may cause false data to be processed by the IT equipment. The RF signals that can radiate from or get into IT equipment are known as EMI.

(1) IT equipment microprocessors operate at very low voltages – usually 5 to 12 volts. Therefore, it is critical that unintentional voltage differences between various units of data-processing equipment in an IT equipment room be extremely small. At 60 hertz this is relatively simple – just tie them together with a low resistance, low-impedance grounding conductor so the enclosures and grounded metal are all at the same (ground) reference potential.

(2) At radio frequencies the solution is not so simple. Low-impedance grounds are not easy to obtain, since the inductive reactance of a conductor is proportional to the frequency. At 30 megahertz (MHz), a length of conductor has an inductive reactance 500,000 times the reactance at 60 hertz. In addition, there is stray inductance and capacitance from conductor to conductor or conductor to grounded metal and resonance effects at high frequencies, making it very difficult to get a conductor of any appreciable length to have the same voltage at both its ends. If there is a difference in potential between the ends of a grounding conductor connecting two pieces of IT equipment, it is possible for data errors to occur.

(3) A high-frequency impulse applied to a conductor travels along the conductor at a finite speed, about 85 percent of the speed of light, until it reaches the end of the conductor. It is reflected back along the conductor, becoming a traveling wave. At some frequencies, the reflected waves meet and reinforce oncoming new waves, creating resonances and standing waves. At or near these resonant frequencies the conductor appears to have an extremely high impedance and does not provide an effective voltage equalizing means between two pieces of equipment. In addition, the conductor can act as an antenna at or near these resonant frequencies, radiating energy that can interfere with other equipment or receiving stray signals from other sources and presenting a false voltage signal to the IT equipment.

(4) These effects are completely unpredictable because the interfering signals are not steady and because IT equipment sensitivity varies. Digital IT equipment operates on binary signals, on or off, or 0 to 1. The circuits are most sensitive at the moment they are switching from one state to the other, and if an impulse occurs at that moment, a false “bit” of data may occur in the system. At other times, the same impulse may not affect the processing. These errors can be extremely difficult to identify.

(5) This points out the need to interconnect all cabinets of the system in such a way that they are at the same potential for all frequencies, from 60 hertz or less to very high radio

frequencies. One of the best ways of accomplishing this is the signal reference grid. Transmission-line testing has shown that standing waves will not cause a significant voltage difference between the two ends of a conductor that is not longer than about 1/10 to 1/20 of a wavelength. The wavelength at 10 MHz is about 100 feet and 1/20 wavelength is 5 feet. The wavelength at 30 MHz is about 32 feet and 1/20 wavelength is a little under 2 feet.

$$\lambda = c/f$$

where λ = wavelength (meters)

c = velocity of light in free space = 3×10^8 meters/second

f = frequency in hertz (cycles/second)

(6) If conductors are connected in a mesh or grid to form a multitude of low-impedance loops in parallel, there will be little voltage difference between any two points in the grid at all frequencies from 60 hertz up to a frequency where the length of one side of one square represents about 1/10 wavelength. A grid made up of 2 foot squares will at any point provide an effective equipotential ground reference point for signals up to more than 30 MHz. If such a grid is installed in the IT equipment room and the enclosure or frame of each piece of IT equipment is connected to it by a short conductor, there should be no equipment noise problems resulting from differences in ground potential between the frames of any two pieces of equipment.

(7) A raised floor in the IT equipment room can be used as the reference grid if of the proper type and design. Most raised floors consist of vertical stanchions or corner supports 2 feet apart that hold up the 2-foot square floor tiles. If the floor is the type that has stringers between the stanchions and the stringers are positively mechanically bolted to them to make a good electrical connection, the stringers will form an excellent 2-foot square mesh. If the floor tiles or panels are metal-clad, they will further reduce the impedance between loops. This is probably the best and least-costly way to obtain the high-frequency reference ground grid. Floor tiles should be used that do not have a zinc electroplated-passivation coating on the tile's sheet metal pan, thereby avoiding potential problems with zinc whiskers. IT equipment room floor tile manufacturers have identified this problem, and no zinc electroplated floor tiles have been manufactured for several years.

(8) The frames of the IT equipment should be connected to the grid by the shortest possible leads with braided copper the preferred material, followed by copper strap, with round conductor least desirable, because braid provides the most effective and round conductor the least-effective results with high-frequency signals. Connections from the equipment frames to the raised-floor grid can easily be kept to eight inches.

(9) If the bolted-stringer type of floor is not installed, a grid can be created by laying a mesh on the true floor, under the raised floor. This mesh also can be of copper wire, (least desirable) flat copper strap, or braided copper strap (most desirable), electrically connected every 2 feet to make a grid of 2-foot squares. Since this grid is on the true floor, it is about 2 feet farther from the equipment enclosures and requires a longer connecting strap from enclosure to grid, reducing its effectiveness a little.

(10) Additional protection against false signals is obtained by using shielded cables to interconnect equipment or using filters and traps to keep unwanted signals out of the system. If shielded cables are used, only one end of the shielding may be grounded. Grounding both ends of the shield would provide a closed current loop that could create an induced current in the shield and damage the shield through overheating.

(11) A higher frequency network reference signal subsystem may be required for frequencies of concern higher than 30 MHz. The optimum interconnecting cable and/or mesh spacing of the equipotential plane should be one-tenth to one-twentieth of the wavelength of concern. For a 500 MHz signal, one-tenth of a wavelength is about 1.2 inches. This small mesh spacing may not be feasible; therefore, the mesh spacing should be as small as practical. As a design objective, the mesh grid openings should be no larger than 4 inches. A ground reference plane made up of a copper mesh with four-inch openings may be embedded in the concrete floor of new facilities. Another option for existing or new facilities is to install a metal sheet or roll of aluminum, copper, or phosphor bronze under floor tiles or carpet. When it is impractical to install an equipotential plane under the floor surrounding the ADP equipment, thin metal sheets can be installed in or on the ceiling of the equipment room. Additional details can be found in MIL-HDBK-419A, Section 1.5.1, Higher Frequency Network.

CHAPTER 5

HARMONICS

5-1. Harmonics defined

Harmonic is defined as a sinusoidal component of a periodic wave having a frequency that is an integral multiple of the fundamental frequency. For example, a component, the frequency of which is five times the fundamental frequency, is called a 5th harmonic. The theoretical maximum amplitude of each harmonic current produced by a converter is equal to that of the fundamental component divided by the harmonic order. For example, the 5th harmonic is equal to 20 percent of the load current; and the 7th harmonic is equal to 14.3 percent; and so on. These values are for an idealized squarewave and, in practice, will be less because of system impedance. The harmonic components are assumed to be in phase with the fundamental. The resulting waveshape will depend on the magnitude and the phase relation of each of the harmonic components.

a. Harmonic distortion factor (HDF) standards are needed to ensure that users are provided with a suitable voltage supply wave form; limit distortions to levels that system components can tolerate; and prevent the power system from interfering with the operation of other systems. In order to compare levels of harmonic distortion in a power system, the HDF is used, and is defined in the Institute of Electrical and Electronic Engineers (IEEE) Standard 519-1992 as:

$$\text{HDF} = \text{square root of } \left(\frac{\text{sum of squares of amplitudes of all harmonics}}{\text{square of amplitude of fundamental}} \right) \times 100\%$$

b. The amount of voltage distortion that can be tolerated on a power system is dependent upon the equipment connected to it and this equipment's susceptibility to nonsinusoidal waveshapes. Power utility companies may be more stringent or relaxed in their specifications for the HDF, and may use different formulas than those given in IEEE Standards. In Canada, for example, the requirements for HDF vary from utility to utility, but in general they range from one to five percent depending on the system voltage level. The higher the voltage level, the more stringent the harmonic limitations requirements. It is, therefore, necessary to check with the power company as to their requirements in limiting harmonic voltages and currents as this may have substantial impact on the drive and filter design. IEEE Standard 519-1992 specifies guidelines with regard to limiting the harmonic voltage and current distortion factor. A summary of these guidelines is given in table 5-1.

5-2. Harmonic sources

The common sources of harmonics in utility or industrial electrical systems are: rectifiers, dc motor drives, adjustable frequency ac drives, uninterruptible power supplies (UPS), arc furnaces, static volt amperes reactive (VAR) generators, cyclo converters, and static motor starters.

a. A static power converter generates harmonic currents the order of which is given by:

$$n = kp \pm 1$$

where: n = order of the harmonic

k = an integer 1, 2, 3 . . .

p = number of pulses of the converter system

Table 5-1. Voltage distortion limits for medium and high voltage power systems

<u>Power System Voltage Level</u>	<u>Dedicated System Converter*</u>	<u>General Power System</u>
Medium Voltage 2.4 – 69 kV	8%	5%
High Voltage 115 kV and Above	1.5%	1.5%

*A dedicated system is one servicing only converters or loads not affected by voltage distortion.

A 6-pulse converter would generate harmonic currents of the order 5th, 7th, 11th, 13th, 17th, 19th, 23rd, 25th, etc. For a 12-pulse converter configuration, the harmonics generated are 11th, 13th, 23rd, 25th, etc. Therefore, a 12-pulse converter system provides a significant reduction in the voltage distortion and, equally important, it eliminates (assuming balanced conditions) the lowest order harmonics of 5th and 7th that are typical of most concern.

b. The presence of these harmonic producing devices in a system does not necessarily constitute a problem. The harmonics may be of sufficiently low magnitude and, therefore, harmless at one extreme, or they may be a magnitude high enough to cause damage to equipment in the system. If in an existing system there is no history of harmonic related problems such as motor failures, telephone interference, etc., then there is likely to be no harmonic problem, and a harmonic analysis study is probably not warranted. However, a good guideline is that if 20 percent or more of the plant load consists of harmonic producing sources, a harmonic study should be considered. This will determine the magnitude of harmonic currents and voltages, and will aid in designing special filters to reduce these distortions.

c. In addition there are other non-linear devices such as arc discharge devices used in arc furnaces and fluorescent lamps. Power supplies for electronic equipment such as UPS, numerical controlled machine and computers, and any load that requires other than a sinusoidal current will be a source of harmonic currents.

5-3. Harmonic technical history

From approximately 1910 to the 1960s, the main non-linear loads came from those few larger users in the electro-chemical and electro-metallurgical industries. They developed means of limiting the harmonic currents that their processes developed and thus minimized the effect on power systems and other users.

a. Small and medium sized adjustable speed drives used motor-generator (M-G) sets to feed dc motors and a few adjustable speed ac drives used wound rotor motors. Still other variable speed drives were steam driven. For the M-G sets, the mechanical linkage between the two systems transmitted power between them and at the same time electrically isolated each system from the other. However, these M-G sets were bulky and tended to be high maintenance pieces of equipment.

b. The first attempt at electrical rectification was accomplished through mechanical means. A motor driven cam physically opened and closed switches at precisely the right instant on the voltage wave form

to supply dc voltage and current to load. At best, this approach was cumbersome since timing the switches and keeping them timed was extremely difficult. In addition, contact arcing plus mechanical wear also made this equipment a high maintenance item. Mechanical rectifiers were soon replaced by static equipment including mercury, selenium, and silicon diodes, thyristors and finally insulated gate bipolar transistors (IGBTs). With the invention and development of the thyristor, cost effective equipment became available to allow standard squirrel cage induction motors to drive pumps, fans, and machines with the ability to control the speed of these drives. The technology grew rapidly and the applications of these drives covered all aspects of process drives in all industries. These non-linear type loads increased dramatically in just the decade of the 1970s. This growth has continued and will continue.

c. Although solid-state rectification appeared to be the panacea to the problems of the older methods, other system problems soon became noticeable, especially as the total converter load became a substantial section of the total system power requirements.

(1) The most noticeable initial problem was the inherent poor power factor associated with static power converters. Economics (utility demand billing) as well as system voltage regulation requirements made it desirable to improve the overall system power factor which normally was accomplished using shunt power factor correction capacitors. However, when these capacitor banks were applied, other problems involving harmonic voltages and currents affecting these capacitors and other related equipment became prevalent.

(2) Another initial problem was the excessive amount of interference induced into telephone circuits due to mutual coupling between the electrical system and the communication system at these harmonic frequencies.

(3) More recent problems involve the performance of computers, numerical controlled machines, and other sophisticated electronic equipment which are very sensitive to power line pollution. These devices can respond incorrectly to normal inputs, give false signals, or possibly not respond at all. More recently, neutrals of four-wire systems (480/277V; 120/208V) have been the latest power system element being affected by harmonics.

5-4. Resonance

The application of capacitors in a harmonic environment necessitates the consideration of the potential problem of an excited harmonic resonance condition. Inductive reactance increases directly with frequency and capacitive reactance decreases directly with frequency. At the resonant frequency of any inductive-capacitive (L-C) circuit, the inductive reactance equals the capacitive reactance.

a. Two forms of resonance which must be considered: series resonance and parallel resonance.

(1) For the series circuit, the total impedance at the resonant frequency reduces to the resistance component only. For the case where this component is small, high current magnitudes at the exciting frequency will flow. From a practical viewpoint, series resonance conditions are source limited. As long as the harmonic source is not excessively large compared to the power factor capacitor bank, the harmonic current is typically within limits.

(2) Parallel resonance is similar to series resonance where the capacitance reactance equals the inductive reactance. However, the parallel impedance is significantly different. At the resonant frequency the impedance is very high and when excited from a source at this frequency, a high circulating current will flow in the capacitance-inductance loop – although the source current is small in comparison.

The most common situation, which leads to parallel resonance in industry, is where the source inductance resonates with the power factor capacitor bank at a frequency excited by the facilities' harmonic sources. In this situation, the harmonics are amplified by the resonant condition and are not source limited.

b. In actual electrical systems utilizing power factor correction capacitors, either type of resonance or a combination of both may occur if the resonant point happens to be close to one of the frequencies generated by harmonic sources in the system. The result may be the flow of excessive amounts of harmonic current and/or the appearance of excessive harmonic overvoltages. Possible consequences of such an occurrence are excessive capacitor fuse operation, capacitor failures, unexplained protective relay tripping, telephone interference, or overheating of other electrical equipment. A calculation of potential problems for resonant frequency can be calculated as defined in IEEE Standard 519-1992 as: $h = \text{square foot of (short circuit MVA at the point of study divided by } M_{var}, \text{ the capacitor rating at the system voltage)}$.

5-5. Electrical loads

a. Until recently, almost all loads were linear, and those that were not were a small portion of the total as to have little effect on system design and operation. Then came the electronic revolution and electronic loads, such as computers, UPS equipment, and variable speed motor drives, have proliferated. These electronic loads are mostly non-linear, and have become a large enough factor to have serious consequences in distribution systems. Overheated neutral conductors, failed transformers, malfunctioning generators, and motor burnouts have been experienced, even though loads were apparently well within equipment ratings. Motor, incandescent lighting, and heating loads are linear in nature. That is, the load impedance is essentially constant regardless of the applied voltage. For ac, the current increases proportionately as the voltage increases and decreases proportionately as the voltage decreases. This current is in phase with the voltage for a resistive circuit with a power factor of unity. It lags the voltage by some phase angle for the more typical partially inductive circuit with a power factor commonly between 0.80 and 0.95, and leads the voltage by some phase angle for the occasional capacitive circuit, but is always proportional to the voltage. For a sinusoidal voltage, the current is also sinusoidal and at the same frequency.

b. A non-linear load is one in which the load current is not proportional to the voltage. Often, the load current is not continuous. It can be switched on for only part of the cycle, as in a thyristor-controlled circuit; or pulsed, as in a controlled rectifier circuit, a computer, or power to a UPS.

(1) Non-linear loads can often create considerable harmonic distortion on the system. Harmonic currents cause excessive heating in magnetic steel cores of transformers and motors. Odd-order harmonics are additive in the neutral conductors of the system, and some of the pulsed currents do not cancel out in the neutral, even when the three phases of the system are carefully balanced. The result is overloaded neutral conductors. Also, many of these non-linear loads have a low power factor, increasing the cost of utility power where power factor penalty clauses apply.

(2) Non-linear load currents are nonsinusoidal and even when the source voltage is a clean sinewave, the non-linear loads can distort that voltage wave, making it nonsinusoidal. It is essential that special characteristics of non-linear loads are understood so that failures on critical systems are avoided.

(3) In rectifiers for dc loads and dc motor speed controls, the incoming ac is rectified and in many cases filtered to remove the ripple voltage.

(4) In ac speed controls, the incoming ac is rectified to dc, which is then inverted by pulsing circuits back to adjustable-frequency ac. The same steps are used in UPS systems to obtain constant-frequency 60 or 415 hertz ac power.

(5) In power supplies for computers, office machines, programmable controllers, and similar electronic equipment, the ac is converted to low-voltage dc, with high-speed switching circuits for controlling the voltage. The dc is used directly by the microprocessors or central processing unit (CPU).

(6) In the past, most motor-driven computer peripherals, such as tape drives and cooling fans, had ac motors. However, in the latest equipment these peripherals use dc motors, increasing the dc load of the computer system.

(7) Conventional rectifier-type power supplies consist of a transformer to raise or lower the voltage, a rectifier, and filtering to remove the voltage variations or ripple from the dc output. Where voltage change is not necessary, the transformer may be eliminated. Voltage control can be obtained by replacing the diodes in the rectifier with thyristors [silicon-controlled rectifiers (SCRs)]. These are gated on (conducting) at any point in the cycle, turn off automatically as the current passes through zero, and are gated on again at the same point in each subsequent half-cycle.

(8) Rectifiers use three-phase power for a 6-pulse circuit, or use transformers to increase the number of phases to create a 12- or 24- pulse circuit. The greater the number of pulses, the less filtering is needed to provide a smooth, ripple-free dc output. There are many variations of these basic rectifier circuits.

(9) A characteristic of all rectifier circuits is that they are non-linear and draw currents of high harmonic content from the source. Diode full-wave rectifiers are least non-linear, conducting as soon as the forward voltage overcomes the small (about 0.7 V) forward bias required. Phase-controlled rectifiers using thyristors do not begin to conduct until gated on and are, therefore, more non-linear.

(10) The standard power supply, with a transformer and an iron-core choke in the filter, is large, heavy, inefficient, and costly. Manufacturers of computers and other microprocessor-based electronic equipment have almost completely changed over to the switching-mode type of power supply, which eliminates the heavy iron-core input transformer and filter choke.

(11) The switcher controls the voltage, switching at a frequency of from 20 to 100 kilohertz (kHz). A newer switcher operates in the megahertz (MHz) range. A transformer on the switcher output provides some voltage control and isolation of the load from the source. The high switching frequency means that the transformer can be small and light. It requires only a ferrite core instead of a steel core. Voltage sensors and control circuits vary the switcher duty cycle (on time) to produce the required output voltage under varying load conditions.

(12) Switching mode power supplies (SMSP) are highly non-linear and a major source of harmonic distortion and noise. The high-frequency harmonics extend into the radio-frequency (RF) range, requiring most manufacturers to include filters in the incoming line to meet FCC requirements on limiting conducted and radiated interference. Modern computers, from the individual PC to the largest mainframe, and most other microprocessor-based electronic equipment use SMPS and are a major source of non-linear load problems.

5-6. Neutral currents

Multiples of the 3rd harmonic current are additive in the common neutral of a three-phase system, but the mechanism that causes this is little understood.

a. In a three-phase, four-wire system, single-phase line-to-neutral load currents flow in each phase conductor and return in the common neutral conductor. The three 60 hertz phase currents are separated by 120°; and for balanced three-phase loads, they are equal. When they return in the neutral, they cancel each other out, adding up to zero at all points. Therefore, for balanced three-phase, 60 hertz loads, neutral current is zero.

b. For 2nd harmonic currents separated by 120°, cancellation in the neutral would also be complete with zero neutral current. This is true in the same way for all even harmonics.

c. For 3rd harmonic currents, the return currents from each of the three phases are in phase in the neutral and so the total 3rd harmonic neutral current is the arithmetic sum of the three individual 3rd harmonic phase currents. This is also true for odd multiples of the 3rd harmonic (9th, 15th, 21st, etc.).

d. The theoretical neutral current with harmonics is at least 1.73 and perhaps as much as 3.0 times the phase current. For pulsed loads, the pulses can occur in each phase at a different time. They will return in the common neutral, but they will be separated by time; therefore, there will be no cancellation. If none of the pulses overlap, the neutral current can be three times the phase current.

e. The effects of additive harmonics in the neutral were first recognized in the National Electrical Code (NEC) many years ago, when Section 220-22 prohibited reduced neutral conductor size for that portion of the load consisting of discharge lighting. The effects of electronic equipment were recognized in the 1987 NEC when the prohibition in Section 220-22 against reducing the neutral was expanded to include non-linear loads.

f. There are several solutions to minimize this problem. Not only must neutral conductor sizes not be reduced for these loads, but they must often be increased. Many engineers are designing with neutral conductors sized for at least 150 percent of the true root mean square (RMS) phase current, including the harmonic content.

g. The harmonic content of the loads may be reduced by means of line filters. Since the manufacturers of the electronic equipment seldom install line filters beyond the minimum necessary to meet FCC requirements, the power-line filters must usually be separate units installed between the source and the loads.

h. For large computers, UPS, or other non-linear loads, the final isolation transformer should be located as close as possible to the load. The neutral conductors from the wye secondary must be oversized as noted, but the conductor lengths would be relatively short. Nothing upstream from the transformer will be affected. However, the transformer may have to be derated.

5-7. Derating power equipment

The ratings of transformers and generators are based on the heating created by load currents of an undistorted 60 hertz sinewave. When the load currents are non-linear and have a substantial harmonic content, they cause considerably more heating than the same number of amperes of pure sinewave. There are two major reasons for this.

a. When steel is magnetized, the minute particles known as magnetic domains reverse direction as the current alternates, and the magnetic polarity also reverses. The magnetizing of the steel is not 100 percent efficient, since energy is required to overcome the friction of the magnetic domains. This creates hysteresis losses which are greater for a given RMS current at the higher-frequency harmonics, where the magnetic reversals are more rapid than at the fundamental 60 hertz.

b. Also, alternating magnetic fields induce currents into the steel laminations when the changing magnetic flux cuts through a conductor. These “eddy currents” flow through the resistance of the steel, generating eddy-current heating losses. Because of the higher frequencies, eddy-current losses are considerably greater for harmonic currents than they are for the same RMS value of 60 hertz current. A lesser, but still considerable, heating effect at higher frequencies is caused by the “skin effect” in the conductors. Currents at higher frequencies are not distributed evenly through the cross-section of the conductor. The magnetic fields tend to force the current flow toward the outside or skin of the conductor. This effect increases as the frequency increases, and also as the magnitude of current increases. At higher frequencies, the center of the conductor carries little or no current. Therefore, the effective cross-section of the conductor is decreased, and its resistance is increased. It behaves as a smaller conductor of lower capacity. As a result, a given current at harmonic frequencies causes more conductor heating than the same current at 60 hertz.

c. The result of hysteresis, eddy current, and skin effect is that the transformer or generator carrying no more than its full-rated RMS current, but supplying non-linear loads with a high harmonic content, will overheat, sometimes to the point of failure. Transformers and generators loaded to less than 70 percent of their rating have been shut down because of over-temperature. Rectifier transformers specifically designed for non-linear industrial rectifier loads have been manufactured to reduce these effects. K-factor rated transformers of various ratings (depending on harmonic content) are readily available for supplying power to non-linear loads without the problem of overheating (as a result of excessive harmonics).

d. As the harmonic currents are drawn by the loads, they act on the impedance of the source, causing harmonic distortion of the source voltage. Motors are normally linear loads, but when the supply voltage has harmonic distortion, the motors draw harmonic currents. These harmonic currents cause excessive motor heating from higher hysteresis and eddy-current losses in the motor laminations and skin effect in the windings. Thus, motors supplied from sources with voltage distorted by other non-linear loads will also overheat unless they are derated. Motors are particularly affected by the fifth harmonic.

e. The solutions to overheating of transformers, generators, and motors as a result of non-linear loads are the same as those for neutral overheating. The equipment must be derated or the harmonic content must be reduced by line filters, or both. Manufacturers should be consulted before designing equipment and discuss effects based on electronics load (harmonic) profile or estimated system distortion.

5-8. Generator control problems

a. Harmonic currents can cause serious problems for generator installations in addition to excessive heating. Modern generators use electronic means to regulate the output voltage of the generator, to control the speed of the engine or prime mover (thus the output frequency of the generator), to parallel generators, and to share the load proportionately among the paralleled units.

b. Many of these control devices use circuits that measure the zero crossing point of the voltage or current wave. At 60 hertz this is acceptable; but with a high harmonic content, there may be many more zero crossings than the normal ones for 60 hertz. This can cause hunting and instability in speed and frequency control, and can make the paralleling of generators difficult or impossible.

c. Load sharing depends on measurement of the load on each unit. The RMS value of the current is simple to determine for a pure 60 hertz sinewave, but using controls based on 60 hertz RMS where harmonics are present will give false readings, sometimes too high and at other times too low. Only more complex true RMS measurements will provide proper operation by using a true RMS meter.

d. Therefore, it is urgent that the generator and control manufacturers are informed of the load characteristics if a generator is to be used alone or in parallel with non-linear loads. If this is not done, the installation may not perform properly and it may be costly to obtain correct operation.

5-9. UPS output harmonic distortion

UPSs are used to supply clean power to computers under all conditions, including total utility power failure. They range from large systems of thousands of kVA for major computer installations to small units of a few hundred VA for PCs. If the loads distort the power supplied by the UPS, then the power fed to the loads will not be truly “clean.”

a. When harmonic currents are drawn by the load, they cause voltage distortion of the source. Since the voltage drop across the source for a given current is proportional to the impedance of the source ($E = I \times Z$), the distortion caused by a given harmonic current is lower for a low-impedance source and higher for a high-impedance source.

b. The total harmonic distortion (THD) of the UPS for a given load depends on the UPS design and output impedance. This is true whether the UPS is the static type or the rotary M-G type. Most UPS manufacturers specify the output distortion of their equipment; <5 percent total harmonic distortion (as a percentage of the fundamental) is typical. However, many manufacturers add a disclaimer, such as “based on linear loads” or “for reactive and inductive loads.” Such a disclaimer means that the THD figure only applies under linear load conditions. Before purchasing any UPS, make certain that it is capable of supplying the actual types of non-linear loads to be connected to it. Discuss the prospective loads with the manufacturer because correcting problems may be costly.

c. UPS equipment utilizing IGBT rectifier technology, working at a 6 kHz frequency avoids harmonic contamination of the source. Input current wave forms have been measured at less than 3 percent THD at 100 percent load and a maximum of 5 percent at 50 percent load. These low levels of harmonics are achieved without the use of any passive harmonic resonant filtering. The input power factor of IGBT rectifiers is 0.98 lagging, so there is no need for power factor correcting capacitors.

5-10. Solution of harmonic problems

a. The use of phase multiplication should be considered in the design stages of a particular power supply. The phase multiplication technique requires special transformer configurations. Retrofits to existing power supplies, i.e., user loads would entail a cost far outweighing the benefits of the scheme.

(1) Phase multiplication theoretically will cancel normal harmonics. However, in practice, both current sharing distributions and phase angles deviate enough to allow only incomplete cancellation. Most references on the subject indicate that 10 to 25 percent of the maximum harmonic magnitudes will remain.

(2) Once systems without higher order phases are in place, there is little the power system engineer can do but resort to external filtering or real-time cancellation methods.

b. Tuned passive filters contain several branches of series R-L-C elements. These are connected in parallel and externally to the non-linear load with the objective of filtering the major harmonics generated by the load.

(1) The harmonic currents do not “magically” disappear; rather they flow through the branches whose impedances have been set to result in a minimum voltage distortion response.

(2) An example of a tuned passive filter containing elements for the 5th and 7th harmonics and a high pass filter for all the higher harmonics is shown in figure 5-1. The filters represent a constant net capacitive VAR generation at the fundamental frequency. The inductor L_p is added to re-establish an overall unity power factor.

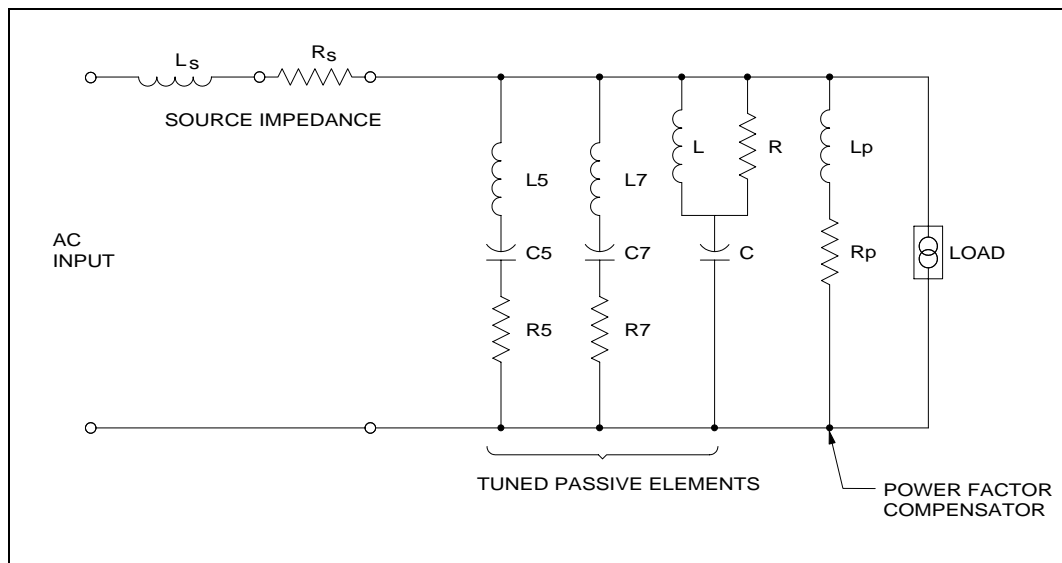

Figure 5-1. Tuned passive filter

(3) An examination of figures 5-1 and 5-2 together will show the complexity of this arrangement. Experience shows there will be eight poles and at least four zeros within the range of harmonic frequencies normally encountered. The filter is located, selected, and tuned with both the load characteristics and source impedance (L_s and R_s) in mind. Changing the load, the source, or the filter's location can result in degraded or unpredictable performance. The units can be costly to design and set, bulky, frequency and component variation sensitive, and intolerant of major system design changes.

c. A passive filter configured for 3rd, 5th, 7th, 9th, and higher harmonics is shown in figure 5-3. The phase control of the current through the inductor L_p can continuously adjust filter/load power factor. With careful design, placement, and tuning, it will effectively handle higher kVA loads of 6-pulse rectifiers exhibiting incomplete harmonic cancellation. However, the drawbacks discussed in the previous sections should not be underestimated.

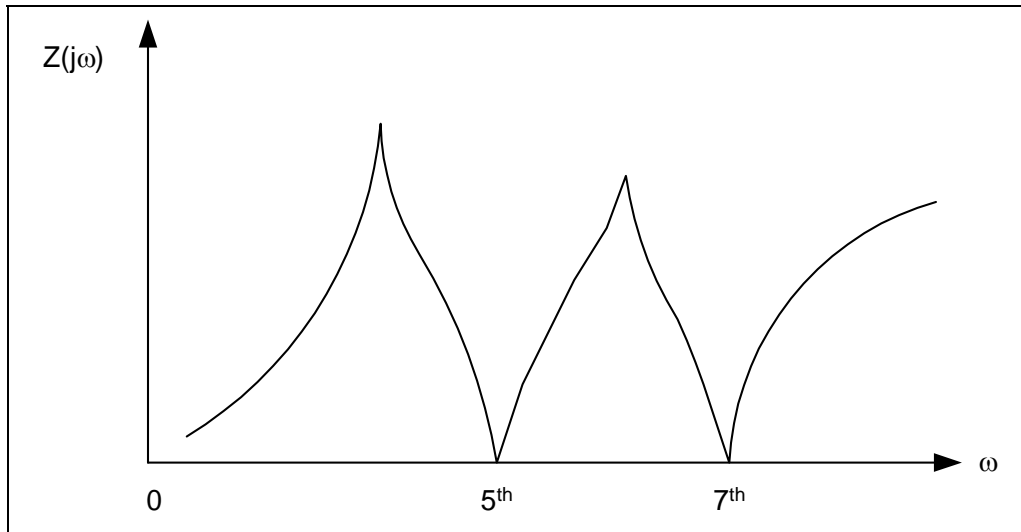

Figure 5-2. Impedance poles and zeros of tuned passive filter

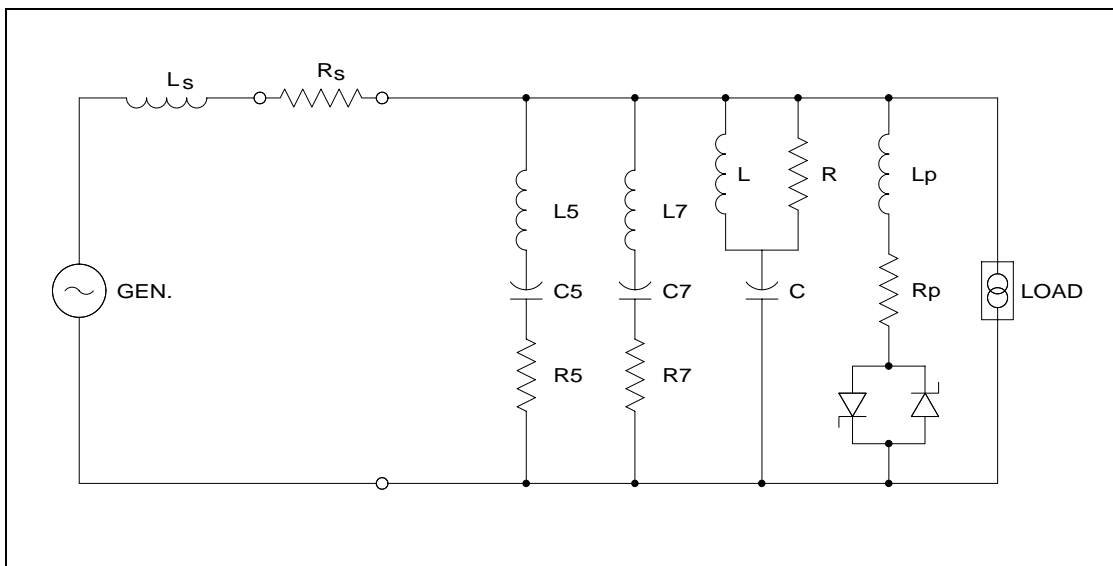

Figure 5-3. Tuned passive filter with static VAR control

d. The active load current compensator is shown in figure 5-4. It performs every function of the tuned passive devices with VAR compensation shown in figure 5-3. The active technique requires an efficient, high speed, switching amplifier. This technique is superior to passive filtering in the following areas.

- (1) It will power-up/power-down without transients.
- (2) Will go into a self-protection mode should a load short-circuit (crowbar) appear.
- (3) Can tolerate some variation in frequency without compromising performance.

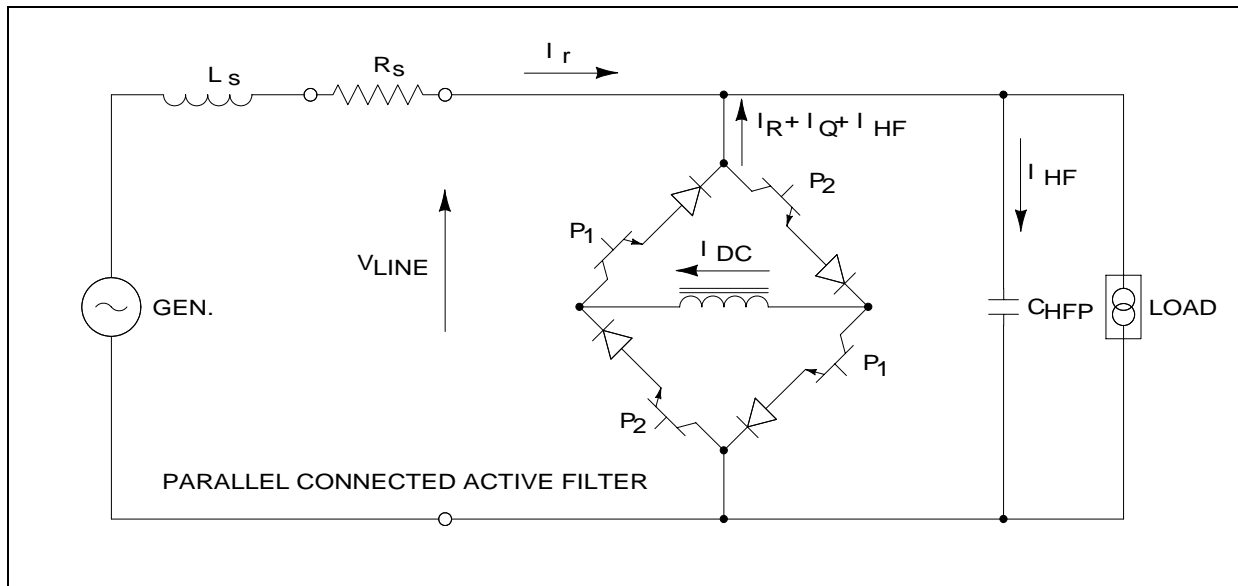

Figure 5-4. Active load current compensation

(4) Will respond to voltage step variation or load current step variation without unwanted transients.

(5) Effectively cancels the harmonic currents at its output node by “real-time” addition and subtraction. In effect, it “linearizes” the load’s non-linear current.

5-11. Measurement of non-sinusoidal currents and voltages

Measuring nonsinusoidal currents and voltages requires radically different techniques than used for sinusoidal wave forms. Conventional meters (analog and digital) measure either the average value or the peak value of the wave form, and then are calibrated to read the equivalent RMS value. The RMS value of a periodic wave is called its effective value; the RMS value of current or voltage is a measure of its true heating value in a resistance. For a sinewave, the RMS value is 0.707 times the peak value, or 111 times the average value. A meter sensing peak or average values and calibrated using these multipliers to read RMS values will agree with a true RMS meter.

a. This only applies if the wave form being measured is a true sinewave. As soon as the wave form contains harmonics, the ratio of true RMS to average or peak value can change drastically.

(1) On a squarewave, the average-calibrated meter will read RMS values about 11 percent high, and the peak-calibrated unit about 30 percent low.

(2) For pulses, the errors can be tremendous, depending on the height of the peak and on the off-time between pulses. The average-sensing meter will read very low, as much as 50 percent, and the peak-sensing meter will read very high sometimes more than 100 percent.

b. Crest factor is the ratio of the peak or maximum value of a wave form to the RMS value. For a pure sinewave, the crest factor is $1/0.707$ or 1.414. However, for a pulsed wave of the same peak value, but with considerable “off” time and a low RMS value, the crest factor will be much higher.

c. Only a meter or relay that measures true RMS values will give correct readings for a nonsinusoidal wave form. Some thermal meters apply an input to a resistive load and measure the heat generated. This gives a true RMS reading, but is very slow in reaction time and, therefore, not practical for most power system measurements. Some analog meters can be made to measure true RMS, but are complex, slow, and limited in scope.

d. Accurate electronic measurement of RMS values has been made practical by micro-processors. RMS measuring circuits sample the input signal at a high rate of speed, typically about 100 times the highest harmonic frequency. To measure the 25th harmonic of a power system, a frequency of 1500 hertz, the sampling rate would be about 150,000 times per second. The microprocessor circuits digitize and square each sample, add it to previous samples squared, and take the square root of the total. This will be an accurate RMS value, regardless of the wave form being measured. This cannot be done continuously, but is done to brief samples and is only possible using the high speed of digital electronic circuitry.

e. Current transformers must be of high quality (with a very wide bandwidth) to sense high and low frequencies accurately, if the RMS reading is to be accurate for high-order harmonics and pulsed currents. This is not a problem for pure 60 hertz sinewaves.

f. The best designs of modern solid-state circuit breaker trips and of other electronic relays use this digital sampling technique and true RMS measurement, combined with high-quality sensors, to obtain accurate tripping on non-linear loads. Older solid-state relays, even though electronic, used average-sensing with RMS calibration. When applied on non-linear loads, these relays can fail to trip on overcurrents or can trip unnecessarily.

g. When induction-disk watt-hour meters are applied on non-linear loads, the harmonics may cause the disk to rotate faster or slower than the same RMS current at 60 hertz, depending on the specific harmonic content. If the watt-hour meter is used for billing, this can result in utility bills that are too high or low, and in most cases, too high.

h. Power factor is the ratio between the true power consumed and the product of the voltage and the current (power factor = ω/EI , which can be transposed to $\omega = EI$ (power factor)). For a sinewave, the power factor is often expressed as the cosine of the phase angle (θ) between the voltage and current, and this equation becomes $\omega = EI \cos \theta$. This is true only for a sinewave, and $\cos \theta$ is not the power factor for non-linear loads. The only accurate way to measure non-linear power factor is to measure the average instantaneous power and divide that by the product of the true RMS voltage and the true RMS current. This can be done by digital microprocessor circuits.

i. When it is necessary to know the actual harmonic content of a wave form, a spectrum analysis can be performed. This breaks the wave form down into its separate harmonics and measures the percentage and the phase angle of each with respect to the fundamental frequency. This analysis has been made practical by digital microprocessor processing. Spectrum analyzers have recently become available that can print out the results in both graphic and tabular form.

5-12. Conclusions

The problems of non-linear loads and the harmonics they generate will continue to cause problems that must be corrected. The techniques recommended to minimize the effects of these loads are:

- a. Oversize neutral conductors to 200 percent of phase conductor ratings.
- b. Locate isolation transformers close to the load.

- c.* Derate transformers, generators, and motors.
- d.* Use true RMS sensing meters, relays, and circuit breaker trip units.
- e.* Make certain that all controls, especially for generator speed and paralleling will operate properly with non-linear loads.
- f.* Select power sources with low output impedances to minimize voltage distortion.
- g.* Provide line filters to remove the harmonic loads from the source.

CHAPTER 6

STANDBY POWER

6-1. Introduction

The purpose of this chapter is to provide guidance and understanding of standby power systems that may be required depending on the reliability of the primary power supply and the desire to maintain the information technology equipment system operable and uninterrupted.

a. There are many electrical power applications which require a continuous and high quality power source. An uninterruptible power supply (UPS) is an assembly of equipment dedicated to providing power free of voltage and frequency variation, transient pulses, line noise, and interruption. Techniques to accomplish these purposes are varied. Combining the characteristics of a UPS system, particularly the static systems, and a standby generator set presents special considerations to ensure compatibility.

b. The major problem associated with reliable power for computer systems is how to reconcile commercial short-duration power interruptions with relatively short time domains in electronic circuits. The goal of most manufacturers in today's technology is to build 4 milliseconds to 1 cycle of carryover, or ride-through time, into their equipment.

c. Table 6-1 identifies computer input power quality parameters for several manufacturers. This table should be used only as a source of some examples since computer designs vary with size of computers, their processing power, and the technology available when the design was created. They are continually changing and the parameters of power needs are changing rapidly with the designs. Although there is a degree of variance between computer manufacturers, the following represents the principal power parameters which are considered important by most major companies. While several of these parameters, such as frequency variation, can be relatively insignificant when power is derived from a commercial power source which embodies vast tie networks, they can become an important design consideration when supplemental or independent power sources are applied as a means of power quality improvement.

d. Two common sources of standby power are ac generators and dc batteries.

(1) A standby generator can be on line in a matter of seconds and continue operating as long as the utility outage lasts. A standby generator set is defined as a unit which supplies continuous electrical service during interruption of normal power. Storage capacity for 30 days of continuous full load plant operation should be provided.

(2) Battery power is a group of electro-chemical cells interconnected to supply a nominal voltage of dc power to a suitable connected electrical load. The number of cells connected in series determines the nominal voltage rating of the battery. The number of positive and negative plates in a battery cell is the basic factor that determines the discharge capacity rating of the entire battery.

(a) "Primary" type cells are capable of being discharged a single time and cannot be recharged effectively, e.g., zinc-carbon flashlight cells. "Secondary" type cells, however, can be discharged and subsequently recharged many times.

Table 6-1. Typical range of input power quality and load parameters of major computer manufacturers

<u>Parameters*</u>	<u>Range or maximum</u>
1) Voltage regulation, steady-state	+5, -10 to +10 percent, -15 percent (American National Standards Institute (ANSI) C84.1 1970) is +6, -13 percent
2) Voltage disturbances/momentary undervoltage	-25 to -30 percent for less than 0.5s with -100 percent acceptable for 4 to 20 milliseconds
Transient overvoltage	+150 to 200 percent for less than 0.2 milliseconds
3) Voltage harmonic distortion**	3-5 percent (with linear load)
4) Noise	No standard
5) Frequency variation	60 hertz ±0.5 to ±1 hertz
6) Frequency rate of change	1 hertz/s (slew rate)
7) Three-phase voltage unbalance***	2.5 to 5 percent
8) Three-phase load unbalance****	5 to 20 percent maximum for any one phase
9) Power factor	0.8 to 0.9
10) Load demand	0.75 to 0.85 (of connected load)

*Parameters 1), 2), 5), and 6) depend on the power source while parameters 3), 4), and 7) are the product of an interaction of source and load and parameters 8), 9), and 10) depend on the computer load alone.

**Computed as the sum of all harmonic voltages added vectorially.

***Computed as follows.

$$\text{percent phase voltage unbalance} = \frac{3(V_{\max} - V_{\min})}{V_a + V_b + V_c} \times 100$$

****Computed as difference from average single-phase load.

(b) Lead-acid cells are by far the most popular type of secondary cell. Properly sized, installed, and maintained, a stationary battery using lead-acid wet cells can have a life expectancy of up to 25 years in stationary applications, depending upon plate design, relationship between cell capacity and load demand, cycling, care during installation, maintenance, control of discharges and recharges, and site environmental conditions. Sealed valve regulated lead-acid (VRLA) batteries offer reduced maintenance and can be placed in rooms without special ventilation since there is no hydrogen off-gas. VRLAs also offer higher power densities than equivalent lead-acid wet cells.

(c) Nickel-cadmium (NICAD) batteries are increasingly applied to emergency lighting and other standby service. The active materials are nickel hydroxide in the positive plate and cadmium oxide in the negative. No gases are generated during discharge, and the gases given off during charging are not corrosive. Initial cost of NICAD batteries is higher than lead-acid on an ampere-hour (Ah) basis. However, at short rates of discharge, from 90 minutes down to 30 minutes the NICAD battery discharges a greater percentage of its capacity than does the lead-acid. This high discharge feature is even more important at extreme rates of discharge. In some applications the Ah capacity of a lead-acid battery must be twice the Ah capacity of a NICAD battery to do the same job.

(d) Batteries bridge the gap from the time power is lost until the standby generator comes up to speed and supplies power via an UPS. For a large computer installation battery time should be at least 15 minutes at full load. This would be enough time to perform a “soft shutdown of equipment” if the generators did not come on line. Certain mission requirements may require additional battery time.

6-2. Codes and standards

a. “Emergency systems” are those classified as essential for human life. The National Electrical Code (NEC), Articles 700, 701, and 702 in the 2005 edition address the electrical safety of the installation, operation, and maintenance of emergency, legally required, and optional standby systems respectively. “Legally Required Standby Systems” which are those systems required and so classed as legally required standby by municipal, state, federal, or other codes or by any governmental agency having jurisdiction. The systems are intended to automatically supply power to selected loads (other than those classed as emergency systems) in the event of failure of the normal source. Article 702 covers “Optional Standby Systems” which are intended to protect private business or property where life safety does not depend on the performance of the system. Optional standby systems are intended to supply on-site generated power to selected loads either automatically or manually. The sources of power discussed are storage batteries, generators, UPS, separate service, and unit equipment.

b. Institute of Electrical and Electronic Engineers (IEEE) 446-1995 entitled “Recommended Practice for Emergency and Standby Power Systems for Industrial and Commercial Applications” addresses the uses, power sources, design, and maintenance of emergency and standby power systems. It includes a general discussion of needs for and the configuration of emergency and standby systems, the power needs for specific industries, the selection of power sources, recommendations for protecting both power sources and switching equipment during fault conditions, recommendations for design of system grounding, recommendations for designing to reliability objectives, and recommended maintenance practices.

6-3. Off-line/on-line IT systems standby power requirements

Most IT installations can be grouped into two general classes of operation in accordance with their usage. These classifications are off line and on line. These categories will be helpful in identifying an IT equipment system’s vulnerability to electrical power disturbances, since an off-line process will rarely

require power buffering or backup sources of equipment. Conversely, it is common for an on-line system to warrant the additional expense of buffering or backup equipment.

a. Off-line IT systems are generally set up to perform one or more programs at a time in a sequential or batch type. Often, 24-hour operation for a heavily loaded system may be necessary.

(1) In the off-line category, for the most part, are business, scientific, and computer center applications. Systems of this type are particularly vulnerable when the programs are lengthy (several hours in duration). Thus the insertion of several natural breaks or checkpoints in the program for segmentation of long programs is highly desirable.

(2) Programming can be designed to save intermediate results at a checkpoint and to have the option of restarting at the last checkpoint which preceded the power interruption. Such a practice in program interruption can be valuable in protecting against peripheral equipment failure. Many current programs are being designed without checkpoint techniques even though the practice has been found to be feasible. Data dependent programs have running times which vary in duration of the magnitude of input data, and accordingly it is difficult to limit the run to much less than a 20-minute period.

b. On-line IT systems, or as they are often called, "real time" systems, are systems which are time and event oriented. They must respond to events which occur randomly in time, often coincidentally. An awareness by the system of events which occur that are external to the computer and beyond its influence is a requirement.

(1) In this category are such applications as industrial process monitoring and control systems, airline passenger reservations systems, vehicular traffic control, certain specialized scheduling applications, international credit/transaction systems, plus many more. With these systems the computer outage problem due to power interruption is usually more critical than in off-line applications. Further, there is generally no merit in segmenting programs. In most cases any outage or power interruption will result in the loss of some data which was available only during the time period of the usage. The form of the input data is not conveniently available for a rerun, but may come from sensors such as thermocouples or pressure transducers which are scanned by a computer.

(2) When a computer controls a process, potential problems resulting from a power disturbance are generally serious enough in terms of product damage or equipment malfunctioning to warrant the use of a reserve or backup power source. Further, any solution, to be adequate, must accomplish the necessary switching to the backup source without power interruption to the computer. It is obvious that the potential losses to several hundred users, or input stations, to a time-shared computer system would warrant the providing of a backup source which can practically guarantee uninterruptible power.

(3) In cases where equipment or process monitoring must be made, as through data logging, protection from destruction of only the core memory content during a power interruption may be adequate. Automatic restart upon return of power is possible to minimize time that the equipment is down and can often be utilized with the additional provision for a manual means of updating the system data or information not gathered or scanned during an interruption.

c. Further differentiation of the single-phase versus the three-phase systems can be made by the magnitude of load. As with most power utilization equipment, smaller power consuming devices can generally be supplied from a single-phase source. The differentiation between single-phase versus three-phase power consuming systems is often necessary since the methods of protection against input power disturbances and outages can be quite different for each system. Some of the IT equipment systems which use single-phase power will employ micro-processors or minicomputers. Others may consist of

multiple single-phase load units distributed in their connection to three-phase power so as to achieve a reasonable load balance when all units are operating. This may result in load unbalance when some of the units are turned off. In general, computers and peripheral units which draw less than 1.5 kVA will often be single-phase. Those which draw more than 10 kVA often require three-phase power. In most cases single-phase loads can be connected to three-phase sources provided load unbalance at maximum load is not excessive, generally taken as 25 percent or less.

6-4. Diesel generator standby systems

The use of a diesel generator for the UPS source can provide extended power for an indefinite power outage and also supply air-conditioning and lighting loads. Information processing equipment rooms will typically overheat within a 15- to 30-minute period if the ventilation system is not working; making the generator set a near necessity for outages in excess of this time. Analysis of battery cost will often justify a generator set at lower cost than choosing a long battery support time with an accompanying restriction of eventually implementing an orderly critical load shutdown. A battery support time of as little as a few minutes may be specified with generator set backup; however, the battery time at full load should be a minimum of 15 minutes. This minimizes unnecessary starting of the generator set during short power interruptions of a few minutes, which occurs more frequently than extended outages.

a. When a power failure occurs, the generator set is automatically started after a short delayed command. When stabilized at normal frequency and voltage, a transfer switch connects the generator set to the UPS. The rectifier/charger frequently is equipped with “power walk-in” that gradually applies load over approximately a 10-second interval when making the transition from battery power to ac source. This minimizes any large block loading disturbances on the source.

b. During normal operation from utility source, the UPS inverter frequency stability is assured by a synchronizing signal that maintains the inverter output phase and frequency in synchronism with the incoming line. While operating from the battery, the inverter operates from a precise internal oscillator to maintain frequency. During generator set operation, the UPS inverter must maintain frequency control or be equipped with over/under frequency disconnect to maintain the inverter frequency within acceptable critical load tolerance despite frequency deviations of the generator set caused by such things as large air-conditioning motor starts. An isochronous governor on the generator set is not usually required with a UPS system if the inverter maintains frequency control during generator set operation. Depending upon UPS system load, it may be desirable or necessary to bypass the UPS in the event of failure within the system, momentary overloads, or system maintenance. When using nonbreak “make-before-break” transfer, both sources are momentarily connected to the critical load. Therefore, the UPS must have synchronizing circuitry to assure the inverter output and bypass source are in synchronism. The bypass source must be within acceptable voltage and frequency parameters for the load. Whenever a standby generator set serves as UPS bypass source, an isochronous governor is recommended to provide minimal frequency deviation to the critical load.

c. The following is a procedure suggested by a generator set manufacturer to use in sizing generator sets that have static UPS systems as part or all of their load. This procedure has four parts.

(1) Establish UPS input kW using supplier data. If not available from supplier, the following procedure and guidelines are recommended to approximate or estimate UPS input kW.

$$\text{UPS input kW} = \frac{\text{UPS output kW} + \text{battery recharge kW}}{\text{UPS efficiency}}$$

(a) UPS output for computer loads is stated in terms of kVA. For approximating, if UPS output kVA is given and kW is unknown, use 0.8 power factor (typical for computer systems).

(b) Battery recharge kW generally ranges from 0 to 25 percent of input kW (15 percent is typical). If it is unknown, use 25 percent of output kW for an approximation.

(c) If UPS efficiency is unknown, the following guidelines are recommended.

0.85 if UPS	<100 kW
0.875 if UPS	≥100 kW but <500 kW
0.90 if UPS	≥500 kW

NOTE: Maximum input with redundant systems is less than total rating of individual systems.

(2) Establish the minimum size generator to contain wave form distortion, i.e., quality of electric power.

(a) For 6-pulse rectifier/charger: minimum standby rated generator set = UPS input kW x 1.6

(b) For 12-pulse rectifier/charger: minimum standby rated generator set = UPS input kW x 1.4

(3) Size the generator to accommodate other loads. Minimum standby generator rating with other loads = (UPS input kW x K) + kW of other loads. Where:

$$K = 1.15 \text{ for 6-pulse rectifier/charger}$$

$$K = 1.10 \text{ for 12-pulse rectifier/charger}$$

(4) Combine “(2)” and “(3)” for final selection. Select larger of value and round to nearest larger size standby generator set.

d. For example, select a standby generator set for powering a UPS rated 200 kVA/180kW. Other loads connected to the generator set total 100 kW.

(1) From supplier data, the UPS input is 255 kW, including battery recharge.

(2) The rectifier/charger is a 6-pulse circuit. Minimum standby rated generator set = 255 kW x 1.6 = 408 kW.

(3) Size for other loads. Minimum standby generator set rating with other loads = (255 kW x 1.15) + 100 kW = 393 kW.

(4) 408 kW is larger than 393 kW; therefore, a standby generator set of at least 408 kW is recommended. A 450 kW standby generator set will satisfy this application. Loads on the generator set frequently include large motors for air conditioning; and other support functions. Following selection of the generator set, a check should be made to determine if the generator set has adequate motor starting kVA capability.

e. Most system incompatibility problems involving generator sets and UPS systems arise because the equipment selection and system design did not consider any power source other than a stiff utility system or “unlimited bus.” When problems do arise, particularly if the system performs satisfactorily on utility, it is very easy to erroneously conclude that it must be the generator set because it works fine on utility. It

is important to note that loads drawing harmonic currents cause distortion from the source, the source does not produce distortion.

f. A standby generator is characteristically of higher impedance than a transformer. Also contributing to the impedance difference is a significant difference in kVA rating between the two sources. Where a unit transformer is sized to carry the total facility load, the standby generator set is often only sized to carry the emergency or critical loads. A generator may have five to 100 times greater sub-transient reactance than the normal source transformer. Consequently, non-linear loads which work fine on utility supplied power may react entirely different when powered by a generator set.

g. Using an oversize generator to reduce reactance may be of some benefit, but a significant reduction in reactance is not usually economically feasible. A doubling of generator rating is required to reduce reactance by one-half.

h. Generators are usually rated for 0.8 power factor. The rectifier/charger may have a lower power factor. Displacement of current with respect to voltage occurs with rectifier phase control. Line power factor can vary depending upon silicon controlled rectifier (SCR) conduction angle. Compounding this are the high frequency harmonic currents which result in added kVARs.

i. Harmonic currents produce high frequency flux changes and cause heating in stator cores. Generator rotor losses also occur because harmonic currents in the stator will induce currents in the pole faces and amortisseur windings. Higher magnetic core temperatures will produce higher winding temperature. Generator stator heating is also a function of I^2R loss, and the winding heating is proportional to the effective or root mean square (RMS) current squared (RMS current being 1.11 times the average value). The RMS value of the distorted SCR circuit input current wave form is typically greater than 1.11 times average current. Derating or using a low temperature rise generator is a means of compensating for increased heat losses.

j. Three-phase sensing minimizes effects of wave form distortion by providing an average of all three phases at any given instant. Since the SCRs in three-phase rectifier loads do not all "gate on" at the same instant, a minimized distortion, average signal of the three phases is processed. In comparison, a single-phase sensing regulator will sense severe distortion occurring at a given instant during the cycle in one phase. Generators having a three-phase sensing network with a floating neutral are common so that wave form notching is effectively blocked from the regulator. Regulator circuits must include features to isolate field power control from effects of distortion. If SCRs are used within the regulator, circuits must be used to prevent the distortion from loaded SCRs interfering with triggering of regulator SCRs.

k. Generator field power must be filtered to minimize interaction with distortion from the load. A well filtered regulator combined with the inherent inductive filtering of a brushless design generator virtually eliminates this problem. Self-excited generators have a well filtered regulator and excitation system which provides voltage control and stability equivalent to that obtainable with a permanent magnet pilot exciter. It is also fully capable of sustaining excitation during the short circuit periods occurring during the commutation of load SCRs without the benefit of excitation sustaining options. A permanent magnet exciter while capable of sustaining excitation during a sustained fault condition, has no advantage in providing excitation during the short duration of load SCR commutation.

l. Common instrumentation used in electric power generation is characterized by wave form distortion error. Measurement of ac current and voltage is standardized on the basis of RMS value, but departure from a sinewave may introduce significant error in many instruments. Accuracy of moving iron-type voltmeters and ammeters, commonly used on generator set panels and switchboards, is generally limited to commercial power frequencies. These are RMS responding meters; however, high

frequency harmonics may produce eddy current, hysteresis, and inductive reactance effects which can cause indication errors of as much as 40 percent. True RMS ammeters and voltmeters employing non-linear converting circuits are available in switchboard cases at a premium cost. These should be capable of at least 5:1 peak to RMS ratio to ensure accuracy.

m. Most electrical devices and equipment will operate relatively unaffected when powered by generator sets with UPS loads. However, knowledge of potentially sensitive devices may be of value in system planning. Many electronic devices containing internal ac to dc power supplies with filtering electronic or control devices that depend upon source voltage “zero crossings” for timing may perform erratically. If these devices are of low power, a simple and low cost filter will usually eliminate any problem.

n. Caution must be exercised where power factor correction capacitors are used. A resonant condition at one of the harmonic frequencies with some part of the line inductance such as a transformer, on-line motor, or the generator is possible. Excessive and possibly damaging currents at the harmonic frequency can flow through the equipment.

(1) Power factor correction capacitors are used primarily for economic reasons; however, they can also be effective in reducing wave form distortion. It may be advisable to keep them off the line until the effects of operating on an emergency generator set with non-linear loads can be observed.

(2) Three-phase motors connected to the same supply lines as an SCR-controlled load have a damping effect on harmonics. Some harmonic energy is absorbed by the motors as heat and may be observed as higher than normal motor temperature rise. A filter or power factor correction capacitor to attenuate harmonic current may be required if temperature rise is excessive.

o. Regulating devices, such as battery chargers, voltage regulators, automatic speed controls, and engine governors with closed loop controls which typically have a reference, error detector, and error correction elements may be susceptible to instability or self-oscillation. This problem is not frequent but may occur where response times coincide and create oscillatory response between equipment. Altering time constants of one of the control systems will usually correct the problem.

p. Another effect of harmonic wave forms is electromagnetic interference (EMI) /radio frequency interference (RFI) noise induced into low level signal circuits such as carrier current, telephone, and electronic engine governors. Basic practices of using shielded wire, good grounding techniques, physical separation, and/or avoiding parallel runs between power leads and signal leads will minimize these problems.

q. A review of the entire generator set distribution system should be made to determine if loads exist which require a source with low distortion wave form. Unless the generator set system is large, it is quite common for other loads to share a common bus with the UPS and distortion may occur.

r. Provisions should be made at generator switchgear to easily connect an external diesel generator (temporarily installed outside the building) if and when required.

6-5. Battery standby systems

This section reviews the factors to be considered when specifying a stationary battery and the accessories serving the battery system.

- a.* A stationary battery system consists of three interconnected subsystems, normally specified in the following sequence – (1) the electrical dc load; (2) the battery; and (3) the battery charger. Each subsystem is described.
- b.* The combination of the charger and the battery becomes a system when it is connected to an electrical load. The load is the equipment that draws dc power from the charger and/or battery. The charger-battery load combination is most efficient only when all of the components are properly matched to each other. The charger converts ac power into dc power that is compatible with the battery's voltage and current characteristics. The charger is the converter section of the UPS which charges the batteries and supplies dc to the inverter.
- c.* When the charger and battery are connected permanently to each other and to the load, and the charger regulates the voltage supplied to the load and the battery, the system is known as a floating battery system. The battery in such systems is mounted normally on a rack or racks housed inside a building or enclosure. The load in this case is the inverter.
- d.* Major users of stationary battery systems are telephone companies and electric power generating and transmission systems. Stationary battery systems also are used widely by industrial manufacturing plants, communications systems, pipe line companies, airports, airline reservations systems, hospitals, police and fire-fighting headquarters, computer backup systems, sewage treatment plants, and many other facilities that place critical reliance on power continuity. Some applications include:
- (1) Voltage dips in the primary power supply can be corrected to specified levels with battery power.
 - (2) Voltage spikes can be absorbed by the battery system before they reach critical equipment.
 - (3) Electrical 'noise' produced by other power sources can be filtered from power circuits by the battery.
 - (4) Current demands that temporarily exceed the capacity rating of power input lines and/or the charger can be met with battery power.
 - (5) During the interruption of primary power (converter or rectifier) supply, the battery system is used as an emergency power source to supply selected loads for a specified time period.
 - (6) When operations require uninterrupted dc power supply for lengthy periods after an outage of primary power occurs, the battery system can serve as a power "bridge" during the time required to switch from the primary power input lines to the alternate power input sources, such as a standby utility power circuit from another substation or an on-site standby generator set.
- e.* A storage battery uses chemical interactions to produce desired voltage; therefore, it is affected by changes in temperature. Performance ratings of stationary batteries are based on a standard temperature of 77°F (25°C). Any deviation from that temperature will affect battery performance and life expectancy.
- f.* The storage battery is constructed of a group of identically sized cells connected in series. The number of cells connected in series determines the voltage rating of the battery. The discharge capacity of the battery is basically its ability to supply a given current for a given period of time at a given initial cell temperature while maintaining voltage above a given minimum value. This capacity is stated in amperes (A) at a given discharge rate. Most stationary battery cells are rated for 8-hour, 3-hour, 1-hour, 15-minute discharge rates to 1.75 volts per cell.

(1) The rated capacity of the individual cell is the rated capacity for the whole battery. Connecting the cells in series does not increase the capacity rating.

(2) The ability of a fully charged cell to deliver a certain number of Ah at a given discharge rate is determined primarily by the size and/or number of positive and negative plates in the cell. Another important factor is the type of construction used.

(3) There are three basic types of lead-acid positive plates, available in a wide range of plate sizes for various capacity ratings. The following choices are available for modern stationary lead-acid batteries.

(a) Pasted plates use either antimony or calcium alloy grids. The design uses the pasted or “flat” plate for both positive and negative plates. A lattice grid in each plate is cast of either antimony or calcium alloy, needed to strengthen the basic lead content of the grid. Antimony alloy contains ingredients that reduce positive plate wear, local action, and charging current requirements. Cadmium alloy grids drastically reduce the frequency of watering when the battery is float charged and seldom cycled. However, frequent cycling will cause the calcium grid in the positive plate to “grow” or physically enlarge, shortening the cells’ life expectancy. For this reason, calcium cells are best suited for applications where deep discharges are infrequent. The life expectancy of a pasted plate battery is usually shorter than either a tubular type or a Plante type.

(b) Multi-tubular positive plates use antimony alloy grids only. Multi-tubular positive plates enclose the active material exposed to electrolyte. The antimony alloy grid consists of spines extending downward from a top bar. Each spine forms the center of a tube filled with powdered active material. Tubular cells provide the greatest power density of any lead-acid stationary battery design. This means that more Ah of capacity are provided per cubic foot of battery volume (at moderate rates of discharge). This feature can be especially important when battery room space is limited. Tubular cells have a relatively long life expectancy when used at moderate rates of discharge.

(c) Plante plates use either pure heavy lead or “Manchex” rosettes in heavy antimony alloy frames. Basic construction of this grid is a heavy antimony alloy configuration in which circular holes have been cast with specially formed walls. Heavily corrugated strips of high purity lead are rolled into spiral buttons or “rosettes” that are forced into the holes. The walls of each hole are convex, having a slightly smaller inside diameter at mid-point in the wall thickness. This “pinches” the button firmly into place. Each lead button exposes five times more active material surface area to the electrolyte than a comparable area on a pasted plate. The buttons also help prolong cell life expectancy by providing a reserve supply of unformed lead for gradual conversion. Manchex cells have recorded performance lives of 25 years or more in many heavy-duty applications. This battery cell combines long life with exceptional reliability. Its precise construction requires the highest investment per Ah capacity, but this cost is substantially reduced when prorated on an annual basis. Manchex cells are an excellent hedge against inflationary trends that could greatly increase the costs of a replacement battery if shorter-lived, low-priced cells are used in an installation.

g. Basic components of a lead-acid cell design for stationary battery applications are listed in their sequence of assembly at the factory:

(1) An element is an assembly of positive and negative plates insulated from each other by separators and “burned” to metal straps. The element is the key assembly of the cell. Its inter-reaction with the electrolyte determines the cell’s performance characteristics.

(a) Each plate consists of a rigid lead alloy grid that provides physical support for relatively porous active materials. The active materials in the positive plates are different from those in the negative plates.

(b) Reaction of the electrolyte and active materials creates a current flow when a load is imposed on the cell. The grids and straps are electrical conductors that carry the current to and from the posts.

(c) The size and number of plates in the element control the discharge characteristics of the cell. The positive and negative plates are sandwiched together in an alternating pattern (neg-pos-neg-pos-neg) with a negative plate at each end of the assembly.

(d) Each positive plate must be separated from its neighboring negative plate by an insulating material, usually a thin sheet of microporous material, ribbed on the side facing the positive plate.

(2) A cell cover is usually a molded plastic cover through which protrude the positive and negative posts to which the element is attached; also includes a vent well with flame arrester.

(a) The cell cover normally is opaque. The element is connected to the posts that usually protrude through the cell cover.

(b) Positive posts are marked either with a plus sign (+) or the letters "POS;" negative posts carry a minus sign (-) or the letters "NEG." Cells with four or six posts are designed for the highest current discharge rates.

(c) The flame arrester vents protect the cells against ignition of internal gases by external flame or sparks.

(3) A cell jar is usually a transparent plastic container which houses the element and electrolyte; a multi-cell jar has a separate compartment for each cell. The cell jar is usually made of a transparent impact-resistant plastic material.

(a) The jars must be large enough to enclose the element while providing reservoir space above and below the element. The upper space accommodates gradual lowering of the electrolyte level, caused by water loss during charging.

(b) The bottom space serves as a collection basin for sediment shed by the plates during many years of service. This sediment must be kept away from the element; otherwise the cell would be short-circuited when the sediment contacts both positive and negative plates simultaneously.

(c) The cell cover is sealed in the cell jar during or after assembly in which the element has been lowered into the empty jar.

(4) Electrolyte is a liquid solution of dilute sulfuric acid in which the element is immersed for the lifetime of the cell.

(a) Electrolyte in lead-acid battery cells is a dilute solution of sulfuric acid and water. The ratio of acid weight to water is measured as specific gravity. Pure water has a specific gravity of 1.000. The quantity of electrolyte in a cell is specified in pounds, kilograms, gallons, or liters.

(b) Acid electrolyte recommended for most stationary batteries has a nominal specific gravity of 1.215 at 77°F, when the cell is fully charged. The specific gravity of acid electrolyte gradually drops as the cell is discharged. When the charger resumes operation after a discharge period, the charging process gradually raises and restores the specific gravity of the electrolyte.

(c) A tropical (low) specific gravity of electrolyte can be considered for longer battery life of cells where the battery room ambient averages above 85°F more than 30 days per year.

(d) A medium or high specific gravity electrolyte is available for special applications such as UPS which in some cases will reduce the battery size. For such types the float and equalize voltages will have to be increased for normal life.

h. Specification of the charger and the lead-acid battery depends on the dc load. Each single item of electrical equipment that will be powered by the stationary battery system must be analyzed. Pertinent data required for each item of the load includes: voltage range (window); current or kW draw; duration of operation (time); number of cycles; frequency of use; depth of discharge; and operating temperature range. After this data has been compiled, the battery and charger can be sized and specified.

(1) A stationary lead-acid battery system can be designed to meet practically any desired voltage rating. Most dc-powered equipment systems are within one of the following major dc voltage groups.

(a) 6-12 volts (emergency lighting units)

(b) 24 volts (audible and visual alarm systems, engine cranking, communication systems)

(c) 32 volts (emergency lighting systems, engine cranking, electric clock systems)

(d) 48 volts (switchgear systems, telephone systems, microwave systems, engine cranking)

(e) 120 volts (switchgear systems; boiler flame control; emergency lighting systems; communication systems; telemetering; supervisory control systems; teletype systems, fire alarm systems, uninterruptible ac power supply systems, large engine cranking, test bench power)

(f) 240 volts (switchgear systems; uninterruptible ac power supply systems, large engine cranking)

(g) Higher voltages (uninterruptible ac power supply systems)

(2) Stationary battery systems are maintained at voltages higher than the nominal system voltage. For example, a nominal 120-volt system is operated usually at 130/135 volts. This is due to a tendency of a battery cell to gradually lose some of its electrical charge due to minor electrochemical reactions that are taking place constantly on the plate surfaces. These losses are made up by constant "float" charging during normal system operations. Float charging voltage is maintained at a precise pre-set level, virtually always higher than the nominal system voltage but lower than the recharge or equalizing charge voltage.

(3) The equipment powered by dc is usually designed to operate within a fairly broad range of voltage supply. This is necessary for two reasons:

(a) to accommodate the gradual decline of battery voltage during discharge, and

(b) to accept voltage increases when required by recharging or equalizing charge operations.

(4) The minimum and maximum permissible voltages accepted by the dc equipment are vitally important to the battery and charger selection. This information is used in selecting the size and number of plates per cell as well as specifying the number of cells in the battery. Voltage ranges for various operating mechanisms are based normally on the Standards of the ANSI, the National Electrical Manufacturers Association (NEMA), and the IEEE.

(a) One common electrical load in stationary battery systems is switchgear. Operating voltage ranges for various types of dc switchgear are listed in the “C37 Series” of standards available from the organizations listed above. These standards include: IEEE C37.13-1990, Standard for Low-Voltage ac Power Circuit Breakers Used in Enclosures; IEEE C37.14-1992, Standard for Low-Voltage dc Power Circuit Breakers Used in Enclosures; IEEE C37.20-1-1993, Standard for Metal-Enclosed Low-Voltage Power Circuit Breaker Switchgear; ANSI C37.16-1997, Low-Voltage Power Circuit Breakers and ac Power Circuit Protectors Preferred Ratings, Related Requirements, and Application Recommendations; ANSI C37.17-1997, Trip Devices for ac and General Purpose dc Low Voltage Power Circuit Breakers.

(b) A typical example of approved voltage ranges, based on a nominal 120-volt system, lists dc voltages between 105 and 140 volts for tripping mechanisms of low-voltage air circuit breakers. If this system is served by a conventional antimony alloy lead-acid battery, it would have 60 cells float charged at 2.20 volts per cell equivalent to a system voltage of 132 volts. During recharging operations following a battery discharge, the system voltage would be raised to 140 volts by temporarily increasing the charger’s output to 2.33 volts per cell. At the end of a pre-set recharging period, the system voltage would return to the float voltage level.

(c) When electronic components in communications and control circuits require a narrow range of permissible dc voltages, the battery engineer must be advised of the fact. The minimum/maximum voltages of such critical hardware should be grouped separately in the equipment description.

(d) One method of lowering maximum battery system voltage is to use fewer cells in the battery. This design can allow recharging at 2.33 volts per cell without exceeding the maximum permissible voltage accepted by the dc equipment. However, the battery must be equipped with cells that are higher in rated discharge capacity, in order to meet the minimum voltage limits.

(e) Another method of reducing maximum battery system voltage is to eliminate the charger’s recharge and equalizing charge voltage. The float charge level in such systems is raised to a voltage which will maintain the battery system under all conditions. This higher float voltage (at 1.215 specific gravity) must never exceed 2.20 volts per cell, except when a special float voltage is recommended. However, such systems require a substantially longer recharge time following a power outage, since the recharge current is limited.

(f) When the dc electrical load inventory includes loads rated for different voltages (i.e., a 120-volt pump motor and a 48-volt circuit breaker), battery engineers recommend that each voltage class be served by a separate battery and charger. It is technically possible to modify the main battery by connecting supplementary cells to provide a higher voltage level for selected loads, but two chargers are essential – one to recharge the 48-volt battery and a second to charge the 120-volt battery.

(5) Another critical factor that must be considered by the system engineer is the voltage drop caused by resistance in conductor runs. Any equipment powered by a battery should be located as physically close to the battery as possible. If the distance between the battery and the load is substantial, the voltage drop can be minimized by using a larger conductor. If this is not feasible, the calculated

voltage loss should be added to the voltage requirement of the load. This will allow the battery engineer to compensate by specifying larger cells for the battery. Voltage drop is especially severe in high ampere applications, where special attention to the problem is recommended.

(a) Each item of electrical equipment is assigned a nominal current or kW rating by its manufacturer. This rating is used by the electrical engineer as a guide when sizing the circuits that feed power to that equipment and any other equipment connected to that circuit.

(b) The battery engineer must know the current ratings, which are a vital part of the load specification. If the load is a given constant wattage, the current output of the battery will increase as the battery voltage declines during discharge.

(c) In addition to the normal A rating, some electrical equipment has another current factor that is seldom rated by the equipment manufacturer, but which is highly important to the battery engineer. This is the temporary high ampere demand, called inrush current, imposed on the power supply when electric motors, etc., are activated. Inrush demands must be determined – or estimated on the high side – so that battery supply voltage will not drop below critical specified minimum limits during the inrush.

(d) Individual equipment operations are normally classified in one of the following categories - continuous load for indicating lights, relays, alarm systems, and other items; time-limited loads, such as motors, emergency lighting, communications systems, etc., which are longer than a minute but shorter than the battery's duty cycle; and momentary current demands, particularly the power needed to close or trip switchgear, which may be imposed at intervals during the duty cycle.

(6) The operational cycle of required equipment is an important factor for consideration in specifying the battery requirements. The duration of operation of each equipment item should be specified in hours, minutes, or seconds, whichever is pertinent. The battery engineer collates this time data with the equipment's ampere or kW rating to determine its effect on the total duty cycle.

(a) When an equipment item is used more than once during the duty cycle, the anticipated frequency of such usage must be specified.

(b) If this frequency is considered variable, depending on such circumstances as equipment positions or status at the time the duty cycle began, the maximum number of possible operations should be specified in the duty cycle. This is necessary to ensure sufficient battery capacity to handle a worst-case situation.

(7) Environmental conditions and location must also be considered when specifying the battery. Normally, storage batteries are sized to perform at 77°F but allowance must be made in the calculations for lower temperatures which require more capacity to meet the load criteria. Freezing of the electrolyte results in water crystals forming but a solid mass is seldom formed. Such crystals damage the plates resulting in reduced life.

(a) Charger and UPS performance are adversely affected by altitudes higher than 3,300 feet (approximately 1,000 meters) above sea level or ambient temperatures above 105°F (40°C). Compensations for these factors can be designed into the lead-acid battery system.

(b) Battery capacity is reduced when battery room temperature is normally lower than 77°F. Battery life expectancy is shortened when the battery room temperature is consistently higher than 85°F.

(8) After an equipment inventory has been compiled, describing all of the electrical loads intended for operation using battery power, the sequence of operation must be scheduled. This listing of dc loads in sequence during the battery discharge is called the duty cycle schedule.

(a) Selection of the proper size of battery depends not only on the current or kW draw and duration of each load, but also the sequence in which they occur. Careful scheduling of the load sequence in the duty cycle can be of considerable help in keeping battery cell size to a minimum, which lowers costs.

(b) A simple stationary battery system with only one continuous load throughout the duty cycle is easy to size. A typical example would be an emergency lighting system in which 50 A are demanded for three hours. Cell selection tables are provided in catalog sheets.

(c) Many stationary battery systems are multi-load rather than single-load systems. When a variety of loads are connected to the battery, sudden increases and decreases in current demands are imposed on the battery system. If the high-current loads can be scheduled for the beginning of the duty cycle, the battery can be sized smaller than if the high-current loads are activated at the end of the discharge cycle. However, if a load is random in nature and could occur at any time during the duty cycle, it is normally good practice to indicate the random load on the schedule as occurring at the end of the duty cycle, when its effect would be most severe. In some cases, it may be advisable to show the random load occurring simultaneously with the highest ampere load in the discharge schedule. The battery engineer must plan for the worst-case situation to ensure meeting the specified protection time requirements. A company representative should be consulted if there is any question regarding placement of the random load in the sequence of the duty cycle.

i. Short-circuits affecting stationary battery systems usually involve the total system voltage and occur chiefly in the dc switchgear or other electrical load circuits. Instantaneous high currents, as high as 9 to 12 times the 1-minute discharge rate to 1.75 volts per cell of the battery, can occur. Therefore, the stationary battery system should be equipped with fault current protective interrupting devices strategically located throughout the power distribution system. This assumes that the power distribution system is capable of carrying the high current rating of the interruption devices.

(1) The individual tripping and closing circuits of each power circuit breaker should have separate fault protective devices. This is necessary to prevent any fault in the closing circuit of a breaker from jeopardizing tripping. A fault in the control circuit of any one device or breaker should not be allowed to interrupt the control power supply to all the breakers and other electrical loads served by the stationary battery system.

(2) Some stationary battery systems are operated without a main protective device because failure of such a device could accidentally shut down the entire system. The designing engineer must review the applicable codes and pertinent factors of the installation before deciding whether or not to install protective devices on the battery's distribution. However, if the battery is installed before the electrical loads are ready to be connected, and if construction work is underway in the general area, engineers recommend protective devices until such time as the loads are ready for connection.

(3) Either one-time fuses or molded-case breakers may be used as short-circuit protective devices. The fuses operate much faster than the breakers when an over-current occurs. A one-time fuse, with 10 times rated current passing through it, will interrupt the circuit in about 0.1 second, compared to approximately 0.7 to 2 seconds for magnetic breakers. Switchgear manufacturers generally recommend and furnish fuses in battery control power circuits.

(4) When sizing these fuses or breakers, engineers generally assume a zero resistance at the location in the circuit for which the short-circuit calculations are to be made. This theoretically represents a worst-case example. In actual practice, the current delivered through a fault will depend on resistance of the short-circuit path; battery's state of charge; battery's electrolyte temperature; and voltage existing at the battery terminals at the time the short-circuit occurs.

j. During the charging and discharging process of battery operation, hydrogen gas is formed. Hydrogen gas is very explosive when exposed to open flames, sparks, and cigarettes.

(1) The room in which the battery is located should be provided with ventilation, so as to prevent the buildup of liberated hydrogen gas. In the USA, Occupational Safety & Health Administration (OSHA) specifies that the concentration of hydrogen gas should not exceed 1 percent. Other countries may permit other levels of hydrogen concentration. Room ventilation must be adequate to assure that pockets of trapped hydrogen gas do not occur, particularly at the ceiling.

(2) Significant amounts of hydrogen are evolved only as the battery approaches full charge. When the cell is fully charged, each charging ampere produces 0.016 cubic feet of hydrogen per hour from each cell. This volume applies at sea level when the ambient temperature is 77°F.

k. Battery chargers used in stationary battery systems are normally constant voltage chargers. Voltage adjustments can be made with precision to 1/100th of a volts per cell. This is necessary because floating voltage and equalizing; voltage levels critically affect battery performance and life expectancy. Voltage level specifications are normally expressed to two decimal positions; i.e., 2.25 volts or 2.33 volts.

(1) Proper specifications and adjustments of the battery charger are the most important factors affecting the satisfactory performance and life of the battery cells in a stationary battery system. Voltage levels from the charger also usually serve the electrical load, so changes in charger voltage output affect the load.

(2) Battery chargers for stationary battery systems normally are specified after determining: system voltage, current, filtered or unfiltered dc output voltage, wall-hung or floor-mounted housing, ac voltage, single- or three-phase ac input power, and frequency of ac input power. The current of ac input power can be specified by the manufacturer after the above factors have been determined.

l. Valve regulated lead acid (VRLA) batteries are sealed except for a valve that opens to the atmosphere when the internal buildup of gas pressure exceeds atmospheric pressure by a predetermined amount. The electrolyte within a VRLA is immobilized either by adding a gelling agent or by using absorbent separators. VRLA cells provide a means for recombination of internally generated oxygen and the suppression of hydrogen gas evolution to limit water consumption. VRLA batteries can be used for the same applications as conventional vented wet cell batteries; however, they are susceptible to two failure modes that are not normally associated with vented cells, dry-out and thermal runaway.

(1) Dry-out can result from excessive water loss as a result of electrolysis or diffusion through the jar and cover walls. Both mechanisms of water loss result from operating at elevated temperatures. The high temperatures can be caused by operation at higher than normal float voltages or higher positive grid corrosion rates.

(2) Thermal runaway can occur if the rate of heat evolution due to the recombination reaction is greater than the rate of heat dissipation. The hotter the battery, the higher the current needed to maintain the float voltage. The increased current then results in still more recombination and heat generation, which further raises battery temperature. The net effect can be the accelerated dry-out or melting of the

battery. The potential for thermal runaway can be minimized by appropriate ventilation around each cell and by limiting the charger output current and voltage by using temperature compensated chargers.

(3) Maintenance and surveillance requirements for VRLA batteries are similar to those required for vented cells except that specific gravity readings and water additions are not possible. Instead, internal impedance or conductance tests can be used to provide information for comparison of individual cell measurements with either initial baseline values or with present values obtained from similar cells.

m. NICAD batteries with high-rate discharge performance are used for applications demanding a heavy surge of current for short periods, such as engine/turbine starting, switchgear control, or inverter supply. This type of cell is characterized by a great number of very thin plates, closely spaced, creating an extremely low-resistance electrical path. Intra-cell members, such as collector bars and posts, as well as inter-cell connectors, are of large cross-section to ensure low resistance. This design takes advantage of the fact that high-rate, short-duration discharge efficiency is more a function of plate surface area and the conductivity of current-carrying structures than of the amount of active material (which establishes the battery's Ah rating). High rate units are available in cell sizes from 85 to 570 Ah capacity and in plastic or steel containers.

(1) For long-rate discharge performance when plate surface area and current-carrying structures have little effect on the efficiency of discharge, it is more economical to use a cell construction with fewer plates, each with relatively more active material. Long rate discharge units are available in cell sizes from 10 to 1245 Ah capacity.

(2) For intermediate-rate discharge performance, plate thickness and plate separation are greater than the high rate discharge type and less than long rate discharge. Intermediate rate discharge units are available in cell sizes from 13 to 1180 Ah capacity.

(3) Proper battery and system performance can be optimized if installation aspects are properly considered during the design. The battery and its charger should be located close to one another for convenience in checkout and servicing. It is particularly important that the battery also be installed as close as possible to its load to minimize cable length and subsequent voltage drop. Cables of sufficient size must be used, particularly in high-rate applications such as engine-cranking and switchgear. The ordinary rules of wire sizing pertaining to 120-volt ac circuitry cannot be used when figuring wire sizes for high-rate discharges. Calculate wire size based on current, voltage, and cable length.

(4) Normal ventilation is entirely adequate for the room in which a NICAD battery is installed. A hood or exhaust fan is not necessary unless the room has no ventilation. During the last portion of high-rate charging, all batteries give off gas (a mixture of hydrogen and oxygen).

(5) If it is necessary to install the battery in a closed compartment, ensure that there is adequate ventilation by arranging for large vents in the bottom, sides, and top. Small holes in each corner must be drilled to allow for drainage of water that might be spilled during battery servicing operations.

(6) If the battery is to be serviced through a cover or hinged door on top of the compartment, allow a minimum clearance of 3 inches between the top of the vent plugs or caps and the battery box cover.

(7) If the battery is to be serviced from the side, allow additional clearance between vent plug or cap tops and cover.

(8) The battery charger is vital to the proper performance, long life, and reliability of the battery it is connected to.

(9) The charger must meet two requirements: its nominal voltage must be the same as the battery and its capacity must be adequate to handle the load – both for the charging of the battery and for any external load, intermittent or continuous.

(10) Battery chargers are usually described in terms relating to their dc voltage and ampere output:

(a) Constant current has a rating and characteristics which permit a constant-current charge to the battery by manual or automatic adjustment over the full charge voltage range of the battery.

(b) Constant potential has a regulated dc voltage output and theoretically has a sufficiently high current output to furnish the maximum current the battery will accept at the regulated voltage.

(c) Modified constant potential has a regulated output voltage with current limiting. Chargers used with NICAD batteries are generally of this type – either float chargers or with the capability of two-rate charging, either manually or automatically switched to high-rate as required by the battery. This type is considered the most satisfactory for standby service.

(11) Like all vented storage batteries, the gas given off by NICAD batteries during high-rate charging is a mixture of hydrogen and oxygen, which is a result of the decomposition of water by the passage of current through the electrolyte.

(12) The gas is completely non-corrosive – cut, under certain conditions, can be potentially explosive. However, even slight movement of air around the battery such as normal room ventilation will dissipate the concentration of the gas.

(13) The NICAD battery uses an alkaline electrolyte – potassium hydroxide (KOH) instead of sulfuric acid.

(14) The specific gravity of the electrolyte of the NICAD battery remains essentially constant (1.180 + 0.020) in both charged and discharged conditions, unlike the electrolyte of the lead-acid battery whose specific gravity changes.

(a) The nominal individual cell voltage is 1.2 volts.

(b) The float charging voltage is 1.40 – 1.42 volts per cell.

(c) High-rate charging voltage is 1.50 – 1.65 volts per cell.

(15) Stationary batteries of the lead-acid or NICAD type have a standard Ah rating based on either the eight- or the ten-hour rate to a specific end voltage, such as 1.14 volts per cell in the case of a NICAD battery which is similar to 2.22 volts per cell in a lead acid system. The number of cells in series will determine the system voltage where for a NICAD battery, 1.2 volts per cell is normally used. Table 6-2 compares the cells required for certain voltages for NICAD and lead-acid batteries. These are typical voltage ratings which represent series connections of cells. The Ah capacity rating is a fixed basis for a constant current discharge for a specific time where the battery is guaranteed to stay above that minimum voltage per cell at that temperature where the base temperature rating is given as 77°F. It must be emphasized that the Ah rating of the battery as a basis for calculation is only good at the particular time given such as eight hours. If a battery is discharged at higher rates, i.e., shorter times than eight hours, it will not perform as efficiently and less total Ah will be obtained. Similarly, a battery discharged for longer than eight hours will operate somewhat more efficiently and extra capacity can be obtained on

discharges of 24, 48, or 72 hours. The factory should be consulted in such load profiles in order to gain the most competitive battery sizing for the application.

Table 6-2. Comparison of cells required for NICAD and lead-acid batteries

<u>Voltage</u>	<u>NICAD Cells</u>	<u>NICAD Cells (nom)</u>	<u>Lead-Acid Cells</u>
12	10	9 – 11	6
24	20	18 – 22	12
48	37	36 – 40	24
125	92	90 – 96	60
240	184	180 – 192	120

(16) NICAD batteries have an advantage when it comes to sizing because of low, medium, and high rate battery types to choose from. Often, a high rate NICAD battery will give substantially higher currents than a competitive type of unit of the same total Ah rating. On this basis, it may offer a much better economic picture.

(a) As an example, three different simple load situations and assuming 25°C and 1.14 end voltage in all three cases, the first case would be the eight-hour discharge rate. The most economical choice here may be the low-rate battery. A comparison of the data and cost for the medium rate and high rate cells must be performed to substantiate this choice.

(b) The next check is the 1-hour discharge rate. Similar comparisons must be performed.

(c) The last check would be to compare the 1-minute rate. After examining the data, it can be determined if the low-rate battery is the most economical choice. Tripping in the switchgear may be a concern where a small medium-rate cell will adequately do the job versus a high-rate battery. Also certain control loads, while they have short durations, have very low currents; therefore, the smallest low-rate battery is quite sufficient for the load application. However, as a general statement, short duration high-rate discharges will be best served by high-rate batteries.

n. Continuous battery monitoring equipment is available which is used in conjunction with a battery charging system. These systems can monitor float charge rate, voltage levels of individual cells or the complete bank, monitor liquid level, and adjust charge cycle and rate of charge.

(1) A well-designed monitoring system can add significantly to the reliability of a system, but it is not designed to replace monitoring and maintenance by qualified personnel.

(2) To insure satisfactory operation of batteries in all types of systems, the batteries must be maintained on a regular schedule. Special safety precautions must be observed to protect maintenance personnel and the equipment when working around batteries.

(3) The area where the battery is installed must be ventilated. Maintaining a proper, well-ventilated environment is the most important maintenance technique that can be performed for batteries since hydrogen, an explosive gas, is emitted from batteries during charging.

(4) During charging, some of the water molecules in the battery electrolyte break down and are separated into the elemental components, hydrogen, and oxygen. The hydrogen and oxygen escape from the battery through the vent plugs, which lowers the level of the water. Therefore, the water should be replaced periodically.

(5) The battery jar is marked with high and low level marks. The level of electrolyte should always be between these marks. A cell or battery could suffer permanent damage if the electrolyte were left to drop below the top of the metal plates. The procedure for adding water depends on whether the cells are equipped with explosion-proof vent plugs or regular plugs. Specific instructions are given by the battery manufacturer. Water is poured through the center of the plug or hole, and eye guards should be worn for safety. Unless there is a specific recommendation from a qualified chemical engineer, acid or electrolyte should never be added to the cells. Water from the plant drinkable water supply can be used in batteries, as long as periodic analyses for impurities are made. When the normal water supply is not suitable, distilled water should be used. No special powders, booster chemicals, or jellies should be added to station batteries.

(6) One sign that the float level charging current is too high is that water must be added more frequently than the normal, once a year addition. Float charge voltage is critical and should only deviate from the recommended level by 1 percent. A very accurate voltmeter should be used in setting float specific to the type of battery and manufacturer and should be checked against the battery supplier's recommendation. A typical voltage for lead acid batteries is 2.22 volts per cell.

(7) A short-duration charge at higher than the float voltage is made periodically to insure that all cells in a battery have an equal charge. Battery chargers are equipped with an equalize/float switch or with a timer switch which automatically limits the duration of an equalize charge.

(8) Specific gravity is read at least once a year. An on-going record is kept both in the battery room and in other plant maintenance records. Specific gravity is read with a hydrometer syringe. The instructions which accompany a battery indicate the safe range of reading for a particular type of battery. To obtain an accurate reading, the battery must have been charging at the specified float rate for at least a few days. The hydrometer reading may be misleading if the battery has been charging at an incorrect rate. Before making a hydrometer reading, hydrometer indication must be corrected for temperature to obtain a reading comparable with past readings. The base temperature for correction is 77°F.

(9) The following safety precautions should be performed during periodic inspections and maintenance on the batteries.

(a) Replace explosion-proof fixtures such as globes for explosion-proof room lights with exact replacement parts.

(b) Do not smoke around batteries or in the battery room.

(c) Turn the room vent fan on for a few minutes before entering.

(d) Wear safety eyeshields or approved goggles while checking or handling the batteries.

6-6. Transfer switches for standby systems

The purpose of the automatic transfer switch in the electrical system along with its related controls, is to switch power from either the normal or the emergency source to the electrical loads. For maximum protection, the automatic transfer switch should always be located as close as possible to the electrical loads it serves.

a. The controls have the intelligence to monitor the normal source. If there's a power outage - a supply transformer burns out, a power line is knocked down, lightning strikes, or any other cause for power to fail – the controls signal the standby engine generator to start. When the generator reaches proper voltage and frequency, the controls cause the switch to transfer the connected loads to the generator. When the normal source is restored, the loads are transferred back to the normal source, and the engine is shut down after a cool-down period. It is all handled automatically by the automatic transfer switch.

b. The transfer switch should include all of the features that are necessary to fulfill its requirements. Such features are voltage and frequency sensing, various time delays, engine control contacts, manual controls, and indicators.

c. When selecting a transfer switch, certain considerations should be made. Some of the basic things that should be considered when selecting a transfer switch are given below.

(1) The two sources (normal and emergency) should never be connected to the load at the same time unless the system is designed for this type of operation (i.e., closed transition transfer switch). Doing so could create a short circuit from one source to the other with damaging results.

(2) The switch contacts should always be closed on one source or the other – never in-between. In-between (not closed on either source) is undesirable because it would mean that the load would not be getting power from either source. The only type of switch that will satisfy proper operation is a true double-throw, inherently interlocked switch; that is, closed on normal and open on emergency, or closed on emergency and open on normal.

d. Power to the load is always going through the transfer switch. It is important that the switch be designed for continuous duty from either source and be able to transfer to and operate from one or the other source at any time. While the switch is connected to one source, the contacts on the other source can become coated from exposure to the atmosphere and thus cause poor contact when the switch transfers to them. The arc that is formed at the contacts when the switch transfers can also cause the current-carrying contacts to deteriorate. To keep them clean and operable, the current-carrying contacts should have high contact pressure and be able to clean themselves with a wiping action when they operate.

e. Emergency systems must respond quickly to assure minimum outage time in accordance with the NEC. Fast operating transfer time is also important when protecting motors with in-phase transfer. Therefore, the operating time for transfer switches through 4000 A should not exceed 1/6th of a second in either direction – normal to emergency and emergency to normal.

(1) A solenoid operator will provide the inherent double-throw operation that is needed. With the single solenoid operator, there are only two possible positions that the switch contacts can be closed on normal, open on emergency; or open on normal, closed on emergency. Obviously, if both contacts were closed, there would be a short circuit from one source to another. If both were open, the load would be disconnected from both sources.

(2) The single solenoid operator power drives the contacts from one source to the other, then mechanically locks them in place with high contact pressure. This simple mechanism eliminates any need for hooks, latches, or motor drives.

(3) Because of the erosive and destructive action of arcs, the main current-carrying surfaces must be protected. Construction should be such that the arc is pulled away from the main contacts. Switches over 400 A should utilize separate arcing contacts to properly protect main contacts. Switches 400 A and under, where arc energy is lower, should utilize arc runners and contact tips.

(4) To prevent the arc from short circuiting one source to another, the arc must be extinguished rapidly regardless of current level or power factor. A wide arc gap is necessary to accomplish this.

(5) To reduce heat and lengthen insulation life, switches over 400 A should have segmented contacts to provide multiple paths for current flow.

(6) Conventional contacts can separate due to the electromagnetic (EM) forces that occur during fault currents. The consequence at this time, if contacts open, is violent arcing with severe erosion and deterioration of dielectric. Blow-out contact construction on switches over 400 A uses EM forces to keep contacts closed until the over-current device clears the fault.

f. Transfer switches are generally located in the main or secondary distribution bus which feeds the branch circuits. The switch must be designed to close against high inrush currents, to interrupt current, to carry full rated current continuously, and to withstand fault currents.

(1) When the contacts on a transfer switch close, they may be required to pass a substantial inrush, or surge, of current; the amount will depend upon the load.

(a) For tungsten lamp load, the cold resistance is approximately 1/15th to 1/17th of the hot resistance. This means that theoretically the initial lamp current will be 15 to 17 times normal operating current. Such inrush currents may take as long as 14 cycles (.23 second) to return to a normal or steady-state condition. These characteristics vary depending upon lamp wattage.

(b) Motor loads are also a source of high inrush currents. If a stalled rotor motor is connected to a source of power, the inrush currents will be in the neighborhood of six times normal running current. A ratio of ten times running current is generally used in designing motor controllers. This may not be a realistic inrush ratio for transfer switches. Transfer switches must be capable of transferring a running motor from one source to another. These two sources are not necessarily synchronized and, therefore, the residual voltage of the motor may be 180° out of phase with the voltage to which the motor is to be transferred. This means that the motor may momentarily draw as much as 15 times normal running current. The transfer switch must be capable of closing on such loads. In-phase monitors are designed to minimize the condition when large motor loads are transferred.

(c) There must be no tendency for the contacts of a transfer switch to weld when closing on loads having high inrush currents. This means that the physical construction of the switch must provide a minimum of contact bounce and have ample thermal capacity. Good engineering practice demands a transfer switch capable of withstanding inrush currents of 20 times full load rating.

(d) Transfer switches should be rated for all classes of load including any combination of motors, electric discharge lamps, electric heating (resistive) loads, and tungsten lamp loads.

(2) Upon retransfer to normal, the switch is normally required to interrupt rated current at full voltage. Ordinarily on transfer to emergency the current interrupted will be zero or relatively small. The transfer switch can also be called upon to interrupt full load currents at full voltage under test conditions. Accordingly, the automatic transfer switch ratings must apply to both normal and emergency contacts.

(a) Wide arc breaking distances combined with magnetic blowout insure rapid arc interruption during transfer from one source to the other. Magnetic blowout coils are less effective at lower current levels and, therefore, the use of wide arc breaking gaps is also required. It is often more difficult to interrupt currents at the 20 percent level than at higher levels.

(b) Installations often require transfer switches to be capable of interrupting at any current level from 20 to 600 percent of the continuous duty rating at a power factor less than 50 percent.

(3) A transfer switch differs from other emergency equipment in that it must continuously carry current to critical loads. The engine generator set is generally required to provide power only during the emergency period, whereas current flows through the transfer switch continuously during both normal and emergency conditions, with an expected minimum life of 20 to 40 years. During this period, fault currents, repetitive switching of all types of loads, and adverse conditions should not cause excessive temperature rise nor detract from reliable operation. Continuous duty operation should be achieved with minimum maintenance.

(a) To meet the requirements for continuous duty, the contact temperature rise of a transfer switch must be well below that established for an eight-hour rated device, and the quality of contact must be sustained through proper contact design, including separate arcing contacts on larger switches rated above 400 A. Arcing contacts prevent or minimize arcing at the main contacts, which would cause contact erosion and affect the ability of the switch to carry current continuously.

(b) When selecting a transfer switch, determine the maximum continuous load current which the transfer switch must carry. Momentary inrushes, such as occur when lighting or motor loads are energized, can be ignored. Select a transfer switch that is either equal to or greater than the calculated continuous current.

(c) Sometimes the transfer switch size is selected to be the same as the over-current device ahead of it on the normal side. Although this may not be necessary, it is a convenience which permits the addition of future loads while remaining within the system's capacity. Sometimes, to obtain a higher withstand current rating, a higher continuous duty rating, a higher continuous duty rated transfer switch may be used.

(4) Transfer switches are designed to withstand the magnetic stresses and dissipate the heat energy resulting from high fault currents. Withstand current ratings vary depending on the switch size and type. For most applications, transfer switches have adequate withstand current rating when used with current limiting fuses or breakers.

(a) To properly evaluate application and coordination of transfer switches with protective devices, a system short-circuit calculation should be made to determine the symmetrical fault current magnitude and the X/R ratio at each point of application. The X/R ratio is the ratio of the reactance to the resistance of the circuit. As the X/R ratio increases, both the fault withstandability of a transfer switch and the fault interrupting capacity of an over-current protective device become more critical.

(b) A transfer switch should be capable of withstanding the available fault current at its location in the system until the over-current protective device clears the fault. The system designer

should determine the available RMS symmetrical fault current at the transfer switch location, the X/R ratio, voltage, and types of protective devices (current limiting fuse, molded case breaker, power breaker) before a properly rated transfer switch with adequate withstand current can be selected.

specific X/R ratio and specific types or classes of over-current protective devices. For example, a 600 A transfer switch is rated for use with Class L fuses in a system having an available fault current of 200,000 symmetrical RMS A. This is based on a maximum size fuse rating of 1200 A, and an X/R ratio not exceeding 6.6. Most installations normally do not exceed an X/R ratio of 6.6 (i.e., power factor of 0.15).

(d) The factors that account for the high withstand current ratings of transfer switches, include blow-on contact structure, thermal capacity, and operational time delay.

(e) In many switching devices, the EM fields which encompass the current-carrying conductor act to force the contacts to separate. Since these EM forces increase exponentially with current, it can be anticipated that the contacts will separate during short-circuit currents because of magnetic effects. The consequence is substantial arcing accompanied by severe erosion, deterioration of dielectric, and possible flashover.

(f) The amount of heat generated at the transfer switch is proportional to the resistance of the parts that carry the current through the switch, multiplied by the square of the current. To provide the thermal capacity needed to cope with this heat, the cross section of the current-carrying parts must be of substantial magnitude to keep the resistance down to a reasonable value. It is also necessary to provide adequate radiating surfaces, along with high contact pressures, to keep heating to a minimum. Most importantly, the contacts on larger switches should provide multiple current paths.

(g) On large transfer switches segmented contacts are utilized to provide multiple paths for current flow through to main contacts. This reduces the heat generated and thereby provides longer life without replacement of contacts.

(h) A voltage drop normally accompanies large fault currents. It is important that the voltage drop does not cause an automatically operated switch to transfer while the switch is carrying the fault current.

(i) Two safeguards are provided: the mechanically held mechanism and a time delay to override momentary dips in voltage. The mechanically held mechanism assures that the switch will not transfer until control voltage is applied to the transfer switch solenoid coil. To prevent energizing the solenoid coil until the over-current protective device clears the fault, a standard nominal time delay, adjustable up to six seconds, is incorporated into the control circuit.

g. Facilities in which relatively large motors are used have been exposed to the sometimes destructive consequences of switching motors off and then back on again (even to the same bus), before the motor residual voltage has decayed. The consequences of reconnecting a motor to a power source while motor residual voltage is high – i.e., the motor rotating the substantial speed at the instant of reconnection – can be extremely high inrush currents which lead to possible breaker tripping, motor damage, and/or coupling damage. The damage is the result of the abnormal mechanical forces which can develop. The problem is growing as more and more motors are being added to emergency and standby systems. The need to understand the cause of high inrush currents and how to avoid them becomes apparent.

h. Two types of loads, which may be termed passive and active, must be considered.

(1) Passive loads include incandescent lamps, heaters, or any load that is predominately resistive. These loads do not store electrical energy. When they are disconnected from a voltage source, the voltage across the load drops to zero almost immediately.

(2) Active loads include rotating electric motors. They store energy in their rotating mass and magnetic fields. The instant the motor is disconnected, it acts as a self-excited generator that can deliver substantial amounts of current because the magnetic flux within the air gap does not collapse immediately. The resulting residual voltage decreases in amplitude exponentially. The length of time it takes is determined by what is called the motor's open circuit time constant. (One time constant is that length of time it takes the residual voltage to fall to 37 percent of its initial amplitude.) Large motors can have time constants of four to five seconds. Thus, when such a motor is disconnected, it will take four to five seconds for its residual voltage to drop to 37 percent of its original value. It will take 20 to 25 seconds, or five time constants, for the residual voltage to go to zero.

(3) In addition to the motors' residual voltage decreasing, the relative phase angle between the motor voltage and supply voltage changes. After the motor is disconnected, its mechanical speed starts to decrease. This, plus the effect of slip (peculiar to induction type motors), causes an ever-increasing change in relative phase between the motor's residual voltage and the supply to which it is being transferred. The motor is now acting as a self-excited generator of decreasing frequency that is coasting in and out of synchronism at an ever-increasing rate until its residual voltage ultimately goes to zero.

i. Out-of-phase transfer (or even reconnection to the same source) presents a problem. The electric utilities have always been concerned with this problem of large motor load transfer and for obvious reasons. But the problem of motor load transfer is not exclusive to utilities. The same situation is becoming more apparent in general applications as electrical loads get larger. Mechanical loads like air conditioners, ventilating fans, elevators, pumps, grinders, crushers, radar antennas, etc., are requiring motors of higher and higher speeds and horsepower. This compounds the problem of motor transfer. Electrical design engineers must be concerned with the design solutions to avoid the abnormal inrush currents which the motor could develop upon reconnection.

j. There are three basic solutions recommended for transferring motor loads without incurring excessively high inrush currents.

(1) One solution is to let the residual voltage across the motor be allowed to drop to zero value where reconnection currents are similar to normal startup currents. This solution creates some problems. For example, the motor must be disconnected until its residual voltage drops to where it can be safely reconnected. The time that the motor must be disconnected is unacceptable in many applications. Furthermore, the motor's residual voltage versus time profile must be known so enough time is allowed for the motor's residual voltage to drop to a safe value. A reconnection voltage of 25 percent is generally accepted as the maximum. However, if the motor were 180° out of phase with the reconnected source, the maximum reapplied voltage would still be 125 percent. The maximum inrush current could be from 25 to 35 percent higher than normal, and the resulting stresses placed on the motor would be from 156 to 183 percent above normal. The manufacturer should be checked to see if the motor could take the 25 percent overvoltage when 180° out of phase.

(2) A second method, overlap (closed transition) transfer with momentary paralleling of the two power sources appears to be an ideal solution at first glance. An uninterrupted load transfer should provide the least amount of system and process disturbance. However, overlap can only be achieved when both power sources are present and properly synchronized by voltage, frequency, and phase angle. In the case of a failing source, overlap transfer may be extremely difficult, if not impossible, to achieve. Overlap transfer can only be used during test transfers and retransfer back from the generator to the utility

when both sources are at full voltage. While the overlap arrangement is technically feasible, it is not always practical because of the reluctance of the utility companies to permit paralleling of extraneous power sources to their lines.

(3) In most applications a more practical solution is to use a conventional automatic transfer switch with an in-phase monitor. This combination is the most popular with system designers and allows the motor loads to be reconnected almost immediately without excessive inrush current. The in-phase monitor, prior to transfer, samples the relative phase angle that exists between the source being transferred to. Once the two voltages are within the required phase angle and approaching zero phase-angle difference, the in-phase monitor signals the transfer switch to operate and reconnection takes place close to synchronism.

(a) With this arrangement, the asset of rapid transfer becomes evident. Also, it is not necessary to know the residual voltage profile of the motors. In most cases, it will probably be high, but it will also be almost in phase. The result is minimal or even non-existent electrical and mechanical shock; thus avoiding unwanted breaker trip and mechanical damage. Furthermore, this result is accomplished without altering the speed of the generator.

(b) In addition to voltage and current ratings, it is also important to consider the operating transfer time of automatic transfer switches used with in-phase monitors.

(c) The operating transfer time of an automatic transfer switch is a primary factor in the proper utilization of an in-phase monitor. For example, the advance angle adjustment of the in-phase monitor is a direct function of the operating transfer time and the frequency difference between the two sources. (For a given advance angle, the faster an automatic transfer switch can transfer, the wider the allowable frequency difference.)

(d) Consider a typical motor load in terms of its mechanical characteristics. Loads are either high inertia or low inertia. High inertia loads include cooling tower fans, chiller motors, centrifugal pumps and fans, centrifuges, rolling mill machinery, motor-generator (M-G) sets, etc. Low inertia loads include rock crushers, conveyor belts, reciprocating pumps, compressors, etc.

(e) The mechanical energy stored in the driven load is a contributing factor to the residual voltage open-circuit time constant. Therefore, high inertia loads are more likely to have longer open-circuit time constants than low inertia loads.

(f) There is a need for in-phase transfer in many existing and proposed systems. For example, there may be a need in an existing installation that has a history of trips on over-current, and/or damage to motors and couplings.

(g) The need for in-phase monitoring is usually determined by the size of the motor and the inertia of the load. As a guideline, difficulties can be expected with motors of 50 horsepower or more, especially if they constitute the only load on the transfer switch. High inertia loads tend to lengthen residual voltage time constants. Still another consideration concerns the nature of the miscellaneous load, other than the motor, connected to the transfer switch.

(h) Dissipative loads reduce residual voltage times. However, capacitive loads used for power factor correction have a tendency to increase open-circuit time constants since they provide additional excitation to the motor's stator windings.

(i) Motor manufacturers will usually provide data regarding their motors' residual voltage time constants under varying degrees of load. However, several motors connected in parallel present problems since it is somewhat difficult, if not impossible, to theoretically determine the resultant time constant of the motor combination. This is so because the larger motors, upon disconnect, tend to drive the smaller motors. Also, the individual loads inertia interact upon one another. Here it is best to empirically find the resultant time constant through the use of recording instruments in order to determine the need for in-phase monitoring. The determination is a function of not only motor size, but also driven load inertia and location of the motor in the distribution system with respect to the automatic transfer switch.

k. Another design accommodation to meet today's needs is provision for proper ground-fault sensing. Ground-fault sensing requires special consideration. This necessitates proper interfacing between various Articles of the NEC.

(1) Article 230-95 of the 1999 NEC states: "Ground-fault protection of equipment shall be provided for solidly grounded wye electrical services of more than 150 volts to ground, but not exceeding 600 volts phase-to-phase for each service disconnecting means rated 1000 A or more."

(2) Article 230.95 of the 2005 NEC defines requirements for ground-fault protection of equipment.

(3) Article 250-30 of the 2005 NEC defines the grounding requirements for a "separately derived system." A "separately derived system" is defined in Article 100 as follows: "A premises wiring system whose power is derived from a source of electric energy or equipment other than a service. Such systems have no direct electrical connection, including a solidly grounded circuit conductor, to supply conductors originating in another system."

(4) Article 250-24(a)(5) of the 2005 NEC states: ". . . A grounding connection shall not be made to any grounded circuit conductor on the load side of the service disconnecting means except as otherwise permitted in this article."

(5) Article 250-2 of the 2005 NEC, defines the general requirements for grounding and bonding.

l. These code requirements have a number of bearings on "Emergency Systems," "Legally Required Standby Systems," and "Optional Standby Systems" as covered by Articles 700, 701, and 702 of the NEC. Consider a 480Y/277 volt system with a four-pole transfer switch and zero sequence ground-fault sensing. A preferred method for isolating the normal and emergency source neutrals is for the automatic transfer switch to provide overlapping neutral transfer contacts. This feature provides the necessary isolation between neutrals, and, at the same time, minimizes abnormal voltages. By means of overlapping contacts, the only time the neutrals of the normal and emergency power sources are connected together is during transfer and retransfer. With a solenoid-operated, conventional double-throw transfer switch, this duration can be less than the actuating time of the ground-fault sensor, thus avoiding false tripping due to unbalance current that might result when using a solid neutral.

(1) In addition to meeting code requirements, features of this arrangement include:

(a) No flow of ground-fault current through neutral conductor that would detract from or effectively reduce ground-fault detection.

(b) No flow of unbalanced current through the generator neutral which would alter pickup of ground-fault sensor and possibly cause nuisance breaker tripping.

(c) The load neutral is always permanently connected to either source of power. There is no momentary opening of the neutral conductor when the transfer switch operates.

(d) Abnormal voltages and transient voltages are kept to a minimum, in that the neutral-to-ground is not broken.

(e) There is no erosion of the overlapping contacts due to arcing, thus maintaining the integrity to carry current with minimum maintenance. The impedance of the neutral circuit does not change.

(f) Conventional ground-fault detectors may be used on both normal and emergency sides.

(g) Permits ground-fault sensing and alarm on the emergency side.

(2) Four pole switches have also been satisfactorily applied where the loads are passive and relatively balanced, providing complete isolation of service and generator neutral conductors. As with the overlapping neutral contacts described above, this approach eliminates possible erroneous ground-fault sensing and nuisance tripping caused by multiple neutral-to-ground connections and satisfies the NEC definition of a separately derived system. However, unbalanced loads may cause abnormal voltages for as long as 10 to 15 milliseconds when the neutral conductor is momentarily opened during load transfer. Transfer switches are frequently called upon to operate during the total load imbalance caused by a single-phasing condition. Inductive loads may cause additional high-transient voltages in the microsecond range. Consequently, the contact of the fourth switch pole may interrupt neutral currents causing arcing and contact erosion. The contact erosion can be minimized if the fourth pole is designed to open last (after three other poles interrupt the load current) and make first without contact bounce. A good maintenance program must reaffirm at intervals the integrity of the fourth pole as a current carrying member with sufficiently low impedance. Both the NEC and Underwriters' Laboratories (UL) recognize the use of four-pole switches for three-phase, four-wire systems. In some countries, including Germany and France, it is mandatory to use four-pole switching devices.

(3) Automatic transfer switches that include full-phase protection have voltage sensors connected across the line on single-phase, two-wire systems, and across the outside conductors on a single-phase, three-wire system. On a three-phase, three- or four-wire system, each phase is monitored; therefore, three voltage sensors are required.

(4) There are cases where only two voltage sensors, connected between the three-phase conductors, have been used to monitor the three phases. However, should one phase conductor open, feedback through the load from the other two phase lines will maintain near full voltage on both voltage sensors and neither will drop out.

(5) Voltage sensors must be the voltage sensitive type since the release voltage of ordinary sensors is generally less than 50 percent of normal voltage. Consider the single-phase, three-wire system under a condition where a fuse has blown in one line. Any relay connected across the outside conductors will have impressed across it one-half of the normal voltage due to feedback through the load. If the relay is not the voltage sensitive type set to drop out above 50 percent voltage, transfer will not be affected.

(6) Where the possibility exists that under open phase conditions (and this applies to both single-phase and three-phase applications) terminal voltage will be sustained at a relatively high value due to generator action of connected motors, voltage sensors having close differential between pickup and dropout are required to detect this condition.

(7) This possibility, as well as the characteristics of present-day lighting, computer instrumentation, and other voltage sensitive loads, has been a contributing factor to the selection of voltage sensors.

m. Static transfer switches use SCRs to conduct current from source to load. These devices turn on when gated, and turn off at the first current zero crossing following removal of the gate signal. The major advantage of static transfer switches is fast transfer without source interconnection. The response to an outage is, in the worst case, less than 8 milliseconds, provided the second source is available. Static transfer SCR technology should be considered when an 8-millisecond outage is the maximum that can be tolerated. It should be noted that most modern computer equipment can withstand a 20-millisecond outage as described in the Information Technology Industry Council (ITI) Curve and Application Notes (appendix B).

(1) The SCRs require the semiconductor junctions to be forward biased. This results in a voltage drop of approximately 1.5 volts per line (or 225 watts per phase in a 150 A switch). This power loss generates considerable heat, which must be dissipated by fans. The fans run continuously, and over-temperature sensors are usually required to set an alarm if there is a cooling malfunction. The switch may not be able to support the load under an overtemperature condition and automatic bypassing may be required to protect the SCRs.

(2) Detection circuits are employed to prevent transfer if an SCR shorts (which would result in a source-to-source connection). If a shorted SCR on the connected source is detected, the opposite source breaker is shunt tripped as protection against a source-to-source connection and transfer to the alternate source is inhibited. Similarly, if circuitry detects an open-phase SCR, the load is transferred to the opposite source to restore power, providing the opposite source is available. Transfer back to the original source is then inhibited.

(3) Unlike the mechanical switch, the controller must be functioning, and providing continuous gate pulses to the SCRs to keep them on or the static switch itself will cause the load to lose power.

n. The hybrid solid-state transfer switch takes advantage of both static and mechanical switching elements. It utilizes the best of each technology and virtually eliminates their shortcomings. A standard electro-mechanical switch provides power to the load through mechanical contacts. The switch is electrically operated and mechanically held. The reliability and cool operation of mechanically locked contacts are maintained. SCRs are added to transfer to the opposite source with fast and precise timing. The result is a transfer switch that meets all requirements of the ITI Curve (appendix B). Planned transfers result in less than a 3-millisecond disruption to the load. An unanticipated loss of source supplying the load will result in an unplanned transfer in less than 20 milliseconds without source-to-source interconnection. The SCR conduction is limited to approximately 15 milliseconds during transfer, and the mechanically locked contacts support load at all other times. This results in low voltage drop across the contacts, and cool operation without requirement for fans or over-temperature alarms.

o. Many users, local governing authorities, Federal agencies, electrical inspectors, etc., frequently require that the transfer switch meet some form of minimum performance criteria before it is considered acceptable. The performance criteria may vary depending on the degree of reliability and quality level desired. Factors which involve the life of the equipment, such as ease of maintenance, fire safety, shock hazards, overload, endurance, temperature rise, and ability to withstand available fault currents, frequently receive consideration as measures of performance.

p. Special consideration should be given to systems that utilize adjustable frequency drives (AFDs) to control motor operation. These electronic devices often consist of SCR assemblies to change the voltage and frequency applied to the motor to vary its torque and speed.

(1) With some AFDs, interruption of the input, be it caused by transfer switch operation or other momentary power outages, causes the device to see a low voltage input. To maintain motor speed, some control sensors immediately change the conduction angle of the controlling SCRs to compensate for the low line condition. The result is that upon immediate reapplication of power, the controlling SCRs are turned fully on causing a severe current inrush. This current inrush is of such a magnitude that protective devices such as fuses can blow or worse yet, the SCRs themselves can be irreparably damaged.

(2) This problem is only partly solved by conventional in-phase transfer or other load disconnect arrangements because other extraneous interruptions of power (such as disturbances on the high lines) will also confuse the AFD voltage sensing circuitry.

(3) Some manufacturers of AFDs have recognized this problem and have included in their systems special high-speed voltage sensing circuitry that detects momentary power outages and shuts down the AFD entirely. Upon reapplication of voltage, the SCRs go from an off condition to a soft start current limiting startup that automatically protects the solid-state switching devices.

(4) When other provisions are lacking, the motor load disconnect control circuit previously described (i.e., disconnect before transfer) can be considered for transfer of SCR controlled loads for AFD motors and other loads such as used by communications companies. The contact, which must be integrated by the AFD system manufacturer, simply signals the SCR control to “power down” before transfer and permits a soft restart after transfer. As indicated above, such controls may protect the SCRs during a power interruption when the transfer switch is operating, but offer no protection when the power interruption is extraneous to the transfer switch.

6-7. Grounding standby power systems

Since the primary consideration in the installation of emergency and standby power systems is to satisfy the need for continuity of electrical service, the type of system grounding that is employed, and the arrangement of system and equipment grounding conductors, will affect the service continuity. Grounding conductors and connections must be arranged so that objectionable stray neutral currents will not exist and ground fault currents will flow in low impedance, predictable paths which will protect personnel from electrical shock and assure proper operation of the circuit protective equipment.

a. Where phase-to-neutral loads must be served, systems are required to be solidly grounded. However, 600 volt and 480 volt systems may be high resistance grounded or ungrounded where a grounded circuit conductor is not used to supply phase-to-neutral loads. High resistance grounded or ungrounded systems may provide a higher degree of service continuity than solidly grounded systems.

b. Where grounded (neutral) conductors are used as circuit conductors in systems that have emergency or standby power supplies, the grounding arrangement must be carefully planned to avoid objectionable stray currents. For example, stray neutral currents and ground-fault currents in unplanned, undefined conducting paths may cause serious sensing errors by ground-fault protection equipment.

c. A grounded (neutral) circuit conductor is permitted to be solidly connected (not switched) in the transfer equipment. Therefore, a neutral conductor is permitted to be solidly interconnected between a service-supplied normal source and an on-site generator which serves as an emergency or standby source.

Grounding connections to the grounded (neutral) conductor on the load side of the service disconnecting means is not recommended, so the grounding connection to the generator neutral should not be made.

(1) Such multiple grounding of the neutral circuit conductor may cause stray currents that are likely to be objectionable and will cause ground-fault current to flow in paths that may adversely affect the operation of ground-fault protection equipment. Grounding connection to the neutral conductor at the on-site generator on the load side of the service disconnecting means is not recommended and may not satisfy code requirements. Where the grounded (neutral) conductor is solidly connected (not switched) in the transfer equipment, the system supplied by the on-site generator should not be considered as a separately derived system.

(2) The grounding connection to the neutral conductor at the on-site generator completes a conducting path for stray neutral current (not switched). The magnitude of the stray current will be a function of the relative impedances of the neutral current paths. Where ground fault protection is provided at the service disconnecting means, the stray neutral current may adversely affect the operation of the ground fault protection equipment.

(3) The multiple grounding connections to the solidly interconnected neutral permit a portion of the ground fault current returning to the normal source to flow through the neutral grounding bond at the on-site generator and bypass the sensor for the ground fault protection at the service equipment. The main service disconnecting means is not supposed to trip for a ground fault on a feeder or branch circuit, so this is not a serious problem provided the feeder to the transfer switch does not have ground fault protection equipment that is actuated by a ground fault current sensor. However, ground fault protection for feeders may be required if the service disconnecting means is equipped with ground fault protection.

d. Where ground fault protection is applied to a feeder from the service equipment to the transfer equipment, the ground fault current may not be accurately detected by a zero sequence ground fault current sensor.

(1) The multiple grounding connections to the solidly interconnected neutral permit a portion of the ground fault current returning to the on-site generator to pass through the sensor for the ground fault protection at the service equipment. This arrangement could result in tripping the service disconnecting means by ground fault current supplies from the on-site generator.

(2) The transfer switch may have an additional pole for switching the neutral conductor, or the neutral may be transferred by make-before-break overlapping neutral contacts in the transfer switch. Where the neutral circuit conductor is transferred by the transfer equipment, an emergency or standby system supplied by an on-site generator is a separately derived system. A separately derived system with a neutral circuit conductor should be solidly grounded at or ahead of the system disconnecting means. The neutral conductor between the service equipment and the on-site generator is completely isolated by the transfer switch and is solidly grounded at the service equipment and at the on-site generator. Where the neutral circuit conductor is switched by the transfer equipment, the stray neutral current paths and the undesirable ground fault current paths are eliminated.

(3) The normal supply and the alternate supply are equivalent to two separate radial systems because all of the circuit conductors from both supplies are switched by the transfer switch. Since both systems are completely isolated from each other and are solidly grounded, ground fault sensing and protection can be applied to the circuits of the normal source and the emergency or standby source as it is applied in a single radial system.

e. Unintentional neutral grounds will cause stray neutral currents that may be objectionable. Therefore, in addition to carefully planning the intentional grounding connections, systems should be kept free of unintentional grounds on the neutral circuit conductors.

(1) Where there are two on-site generators connected for parallel operation, the neutral conductor is grounded at the generator switchgear instead of at the generator. Where the generator switchgear is adjacent to the generators, the grounding connections may be made in the generator switchgear.

(2) Switching of the neutral conductor permits grounding of the neutral at the generator location. This may be desirable for the following reasons.

(a) An engine-generator set is often remotely located from the grounded utility service entrance, and the ground potentials of the two locations may not be the same.

(b) Good engineering practice requires the automatic transfer switch to be located as close to the load as possible to provide maximum protection against cable or equipment failures within the facility. The distance of cable between incoming service and the transfer switch and then to the engine-generator set may be substantial. Should complete cable failure occur with the neutral conductor not grounded at the generator location, the load would be transferred to an ungrounded emergency power system. This could jeopardize emergency service continuity and possibly lead to additional failures. Concurrent failure of equipment (breakdown between line and equipment ground) after transfer to emergency power may not be detected. Thus the generator frame may approach line potential, causing a substantial voltage difference between the generator frame and the neutral conductor.

(c) Some local codes require ground fault protection while the engine-generator is operating. This may present a sensing problem if the neutral conductor of the generator is not connected to a grounding electrode at the generator site and proper isolation of neutrals is not provided.

(d) When the transfer switch is in the emergency position, other problems may occur if the engine-generator set is not properly grounded. A ground fault condition could cause nuisance tripping of the normal source circuit breaker even though load current is not flowing through the breaker. Furthermore, both the normal neutral conductor and the emergency neutral conductor would be simultaneously vulnerable to the same ground fault current. Thus a single fault could jeopardize power to critical loads even though both utility and emergency power are available. Such a condition may be in violation of codes requiring independent wiring and separate emergency feeders.

f. Where a transferable load is supplied by a system that is derived from an on-site isolating transformer and the transfer equipment is ahead of the transformer, a grounded (neutral) circuit conductor is not required from either the normal or alternate supply to the transformer primary.

(1) The isolating transformer permits phase-to-neutral transferable loads to be supplied without a grounded (neutral) circuit conductor in the feeders to the transfer switch.

(2) The system supplied by the isolating transformer is a separately derived system, and if it is required to be solidly grounded, it should be grounded in accordance with code requirements. The neutral circuit conductor for the transferable load is supplied from the secondary of the isolating transformer.

g. If the on-site generator is rated 480Y/277V or 600Y/347V, its neutral may not need to be solidly grounded because the neutral is not used as a circuit conductor. Therefore, the type of system grounding for such a generator is optional. However, the generator frame should be solidly grounded whether its neutral is ungrounded, high resistance grounded, or solidly grounded.

h. In ground fault current return paths where the grounded (neutral) circuit conductor of a transferable load is isolated by a transformer, any stray neutral current or ground fault current on the secondary of the isolating transformer will have no effect on ground fault protection equipment at the service equipment or at the generator.

i. Where the grounded (neutral) circuit conductor is solidly connected (not switched) in the transfer equipment, an emergency or standby system supplied by an on-site generator should not be considered a separately derived system. The solidly interconnected grounded (neutral) conductor needs only to be grounded at the service equipment.

(1) The solidly interconnected neutral conductor is grounded at the service equipment only and there are no conducting paths for stray neutral currents. If the generator is not adjacent to the service equipment, the generator frame should be connected to a grounding electrode such as effectively grounded building steel.

(2) Where the solidly interconnected neutral conductor is grounded at the service equipment only, the ground fault current return path from the transferable load to the on-site generator is through the equipment grounding conductor from the transfer switch to the service equipment, thence through the main bonding jumper in the service equipment and the neutral conductor from the service equipment to the generator.

j. The ground fault current might trip the service disconnecting means even though the ground fault is on a circuit supplied by the generator (non-switched neutral). A signal could be derived from a ground fault sensor on the generator neutral conductor to block the ground fault protection equipment at the service in case of ground faults while the system is transferred to the generator. Such blocking signals require careful analysis to ensure proper functioning of the ground fault protection equipment.

k. If the neutral conductor between the service equipment and the transfer switch is intentionally or accidentally disconnected, the generator will be ungrounded. Therefore, the integrity of the neutral conductor must be maintained from the service equipment to the transfer switch while the load is transferred to the generator. The equipment grounding conductor must also be maintained from the service equipment to the transfer equipment in order to provide a ground fault current return path from the transferable load to the generator.

l. For increased reliability, multiple transfer switches, located close to the loads, are often used rather than one transfer switch for the entire load. Therefore, consideration should be given to the possibility of cable or equipment failure between the service equipment and the transfer switches, thus possibly causing an ungrounded emergency or standby power system.

m. Three-phase, three-wire, 480 volt and 600 volt systems, which are used prevalently, do not require the use of grounded conductors as circuit conductors. There are more system grounding options where emergency and standby power systems do not require a grounded circuit conductor to supply phase-to-neutral loads.

n. In many installations the service to the premises will be solidly grounded, three-phase, four-wire where a grounded (neutral) circuit conductor is not required for loads that are provided with an on-site emergency or standby supply. An on-site emergency or standby supply is not always required to have the same type of system grounding as the normal supply to the premises.

o. The generator supplies a three-phase, three-wire system. If the generator is rated 480Y/277V or 600Y/347V, it need not be solidly grounded because its neutral is not used as a circuit conductor. An on-site generator that is not required to be solidly grounded may be high resistance grounded or ungrounded. A high resistance grounded or ungrounded emergency or standby power supply provides a high degree of service continuity because the circuit protective equipment will not be tripped by the first ground fault on the system. If the generator is solidly grounded, it must be grounded at or ahead of the generator disconnecting means.

p. Interlocked circuit breakers are used as the transfer means. Where a grounded (neutral) circuit conductor is not required, the type of transfer equipment that is employed is not a consideration in selecting the type of system grounding for the emergency or standby supply.

q. Interlocked circuit breakers should not be selected as a transfer means without considering additional means to isolate the normal and alternate circuit conductors and equipment for maintenance work. The overall reliability of a system may be reduced due to additional exposure where the circuit conductors from the normal supply are solidly connected to the circuit conductors from the emergency or standby supply. The circuit wiring for an emergency system should be kept entirely independent of all other wiring or equipment except in transfer switches or in junction boxes and in fixtures for exit and emergency lighting.

r. A 480 volt or 600 volt, three-phase, three-wire, on-site generator that is high resistance grounded may serve as an emergency or standby power supply for a three-phase, three-wire system that is normally supplied by a solidly grounded service.

s. Where the three-phase, three-wire critical load is relatively large compared with loads that require a grounded (neutral) circuit conductor, a high resistance grounded emergency or standby power supply is sometimes considered. This arrangement requires an on-site transformer for loads that require a neutral circuit conductor. If an on-site transformer is provided for emergency lighting, it must be supplied from the normal service and the emergency supply through automatic transfer equipment.

t. The supply transformer for the normal service and the on-site generator are both high resistance grounded. There are no provisions to supply phase-to-neutral loads.

u. The ground fault current return path to the on-site generator is completed through the grounding resistor. The grounding resistor limits the line-to-ground fault current to a magnitude that can be tolerated for a time, allowing the ground fault to be located and removed from the system.

v. High resistance grounded systems should not be used unless they are equipped with ground fault indicators or alarms, or both, and qualified persons are available to quickly locate and remove ground faults. If ground faults are not promptly removed, the service reliability will be reduced.

CHAPTER 7

LIGHTNING

7-1. Lightning effects on power systems

The frequency of thunderstorms is important in the protection of power systems. The frequency of occurrence of strokes to transmission lines and open country is an indication of the exposure to lightning that an electric power system experiences.

a. An isokeraunic map published by the National Weather Service, which indicates the annual number of thunderstorm days; that is, the number of days on which the weather observer hears thunder or either cloud-to-cloud or cloud-to-ground lightning is useful in planning lightning protection. Using an isokeraunic level of 30 as a reference, an analysis of several thousand measurements made of lightning strokes to transmission lines indicates that a line with a single, 100-foot high ground wire collects 100 strokes per 100 miles per year. A similar line with two overhead ground wires receives more strokes since it collects strokes in a wider swath. The total number of strokes to a line tends to increase with increasing height and decrease with decreasing height.

(1) Knowing the number of strokes to the above transmission lines, we can calculate the number of strokes per unit area (density) by first determining the swath in which a line collects strokes. Again, based on an isokeraunic of 30, the density is 13.7 strokes per square mile per year.

(2) The number of strokes to transmission lines or open ground is assumed to vary directly with isokeraunic. The isokeraunic or storm days do not necessarily reflect the actual number of strokes to earth, however, since a single clap of thunder or a series of thunderstorms lasting several hours would both be counted as one storm day. Thus, the number of strokes to earth can vary widely for a given isokeraunic.

b. In designing lightning protection for power systems, how lightning enters the system, both by direct strokes and by induced surges from nearby strokes; the propagation of surges within the system; and the effects of these surge voltages and currents on the circuits and apparatus within the system must be considered.

(1) Lightning surges entering a power system through direct strokes are the primary concern in planning surge protection. These strokes may hit phase conductors directly, or they may strike the overhead ground wires or masts that shield the conductors. In either case, it is necessary to understand the associated surge currents and voltages produced before a protection system can be designed.

(2) A lightning stroke terminating directly on phase conductors or equipment terminals develops a very high voltage, which, with no surge protection, will flash over the insulation in the majority of cases. If the flashover occurs through air or across porcelain insulation, it rarely causes permanent damage. If, on the other hand, the flashover occurs through solid insulation such as in a transformer or cable, permanent damage results.

c. The magnitude of surge voltages applied to equipment and line insulation systems can be limited by providing grounding masts or ground wires to intercept direct strokes. Even with a shielding network,

though, there is some chance of flashover, depending on stroke current magnitude, impedance of the shielding system, and the amount of insulation between the network and the energized circuits.

d. A lightning stroke terminating near a transmission line can induce a voltage in the circuit which seldom exceeds 500 kV. Lines, shielded with overhead ground wires and operating at 69 kV and above, generally have sufficient insulation to prevent flashover by voltages in this range. The same applies to some well insulated 34.5 kV lines. Lower voltage lines, however, with insulation levels appreciably below 500 kV, may be flashed over by induced surges. In most cases, these circuits do not have ground wires, and are, therefore, subject to flashover each time they are contacted by a direct stroke. In general, flashovers by induced surges do not create a significant problem since the number of flashovers from direct strokes far exceeds those from induced strokes.

e. A lightning stroke terminating on a power system initiates traveling waves which propagate within the system. To determine the resulting surge voltages and currents in various parts of the system, a traveling wave analysis is required. Simple networks with linear impedances can be analyzed manually; more complicated networks, characteristic of practical power systems, require analog or digital computer analysis.

(1) First, consider a stroke terminating on the phase conductor of a transmission line. The stroke initiates voltage and current waves traveling at the speed of light in each direction from the terminating point. With linear impedance, voltage and current have the same waveshape.

(2) The traveling waves are represented by the equation:

$$e = iZ$$

e and *i* are the voltage and current, respectively, of the traveling wave. *Z* is the conductor surge impedance.

(3) Surge impedance is circuit impedance as seen by a transient such as lightning. For an open-wire conductor:

$$Z = \text{square root of } (L/C) \text{ or } (LC)^{1/2}$$

L = inductance/unit length

C = shunt capacitance to ground/unit length

(4) A typical surge impedance for a line conductor is 400 ohms. Corresponding values for *L* and *C* should be 0.4 H/feet and 2.5 micro-F/feet, respectively.

(5) Assuming that the stroke current, *I*, is equal to 2*i* (that is, the stroke current divides equally at the terminating point), the conductor voltage for a 10,000 A stroke is:

$$\begin{aligned} e &= \frac{IZ}{2} \\ &= \frac{10,000 \text{ A}}{2} \times 400 \text{ ohms} \\ &= 2,000 \text{ kV} \end{aligned}$$

Thus, a traveling wave current of 5,000 A (*I*/2) generates 2,000 kV on the transmission line.

(6) The traveling waves initiated by the stroke continue to propagate along the line until a discontinuity is encountered. At this point, voltage and current waves are reflected back along the line, and at the same time, traveling waves are transmitted beyond the point of discontinuity. Points of discontinuity may be an open circuit breaker, a transformer, another connected line, or a flashover on the line.

(a) To a lightning surge, a transformer appears as a large capacitor and behaves essentially as an open circuit. As the traveling voltage wave encounters an open circuit, a voltage wave of the same magnitude and polarity as the incoming surge is reflected. The incoming and reflected waves combine, resulting in double the traveling wave voltage ($2e$) at the open circuit or transformer termination. This is the well known phenomenon of voltage doubling at the end of a line.

(b) For an open circuit termination, the reflected current wave has the same magnitude as, but opposite polarity to, the incoming wave, resulting in zero current at the open end of a line.

(c) Now consider a line terminated in a perfect short circuit. The incoming and reflected voltage waves have the same magnitude and opposite polarity resulting in zero voltage at the terminal. The current waves have equal magnitude and the same polarity, resulting in double the traveling wave current ($2I$). This is the well known phenomenon of traveling wave current doubling when it encounters a short circuit.

(d) An arrester discharging a current at the end of a line is a close approximation to the short circuit case, since the arrester resistance is very low compared with the line surge impedance. The current which the arrester must discharge, therefore, is nearly double the line traveling wave current. This is an important concept in considering arrester discharge duty from lightning surges.

(7) Another useful concept which can be calculated simply is the determination of the surge voltage in a substation with any number of connected lines.

(a) The substation voltage can be written:

$$E = \frac{2e}{n}$$

e = incoming traveling wave voltage

n = total number of connected lines including that on which the surge originated

Assuming an incoming voltage of one per unit (p.u.),

$E = 2, 1, 0.67,$ and 0.5 p.u. for one, two, three, and four connected lines, respectively

(b) This simple calculation illustrates the advantages of multiple lines in reducing surge voltage in a substation.

(c) As noted previously, typical surge impedance for a phase conductor is 400 ohms. Some other typical values are:

Overhead ground wire – 450 to 500 ohms

Two overhead ground wires (in parallel) – 350 ohms

Steel transmission tower – 200 ohms

Cables – 15 to 40 ohms

(d) The propagation velocity in each of these elements is essentially that of light, with the exception of cables in which propagation velocity is about 50 percent of that of light, depending on the dielectric constant of the insulating material. These values are useful in representing power systems in detailed traveling wave analysis using analog or digital computer methods.

f. In protecting power systems against lightning, surge voltages and currents must be considered. In general, lightning protection is primarily concerned with surge voltages; surge currents cause less concern. A lightning stroke to a power system develops very high surge voltages across equipment and line insulation systems. If these voltages exceed the insulation strength, a flashover occurs. A flashover through air or over porcelain insulation (commonly used for transmission line insulation) does not usually produce permanent damage. In generators, transformers, or motors, however, where solid insulating materials are used, a flashover results in permanent damage.

g. Once lightning enters a power system, the surge current is unlikely to cause any damage. Although the current may be extremely high, it is very short lived and can easily be handled by a small conductor. The largest recorded conductor to be fused or vaporized by a direct stroke was a No. 10 AWG. The size of conductors, installed expressly for conducting lightning currents, is usually determined by mechanical strength considerations, rather than by current-carrying capacity. On some rare occasions overhead ground wires have been severed by lightning at the point of contact. This is probably due to the stroke channel heating the conductor at the point of impingement, rather than from simply conducting the lightning current.

7-2. Principles of protection

It has been shown that a modest lightning stroke of 10,000 A develops a 2,000 kV voltage when it terminates on the phase conductor of a transmission line. Obviously, lines and equipment cannot be insulated to withstand voltages in this range. A more practical alternative is to limit voltages to a much lower level. This involves two basic principles: the use of masts and overhead ground wires to shield equipment and circuits from direct strokes; and the application of arresters to limit surge voltages to levels well below practical equipment insulation levels.

a. Shielding masts are commonly used in substations and overhead ground wires are used in both substations and on transmission lines. Both use the lightning rod principle. The following calculation illustrates how a well-grounded mast limits the surge voltage magnitude.

(1) Consider a mast grounded through a 5 ohm resistance and receiving a 10,000 A stroke.

$$\begin{aligned} \text{Voltage developed} &= 10,000 \text{ A} \times 5 \text{ ohms} \\ &= 50 \text{ kV} \end{aligned}$$

(2) The voltage at the top of the mast may be somewhat higher since our calculation ignores inductive drop. However, this voltage is significantly less than the 2,000 kV that would be developed for the same stroke on a conductor. Grounded masts and grounded wires, then, offer an important reduction in the magnitude of surge voltages.

b. Even with an effective shielding system, the surge voltages to allow for voltages developed by strokes to the shielding network must be limited to magnitudes consistent with practical and economical equipment insulation levels. On rare occasions strokes may also bypass the shielding system and terminate directly on the energized circuits. For these situations, an arrester is used to control and limit

surge voltages to a safe level. The arrester, applied on or near the terminals of the protected equipment, is connected from phase to ground. Under normal operating conditions, the arrester has no effect on the power system. Under surge conditions, the arrester will spark over and conduct the surge current to ground, limiting the voltage applied to the equipment insulation to a safe level. After conducting the surge current to ground, the arrester will interrupt the power-follow current and restore itself to its normal operating conditions.

7-3. Lightning protection systems

Modern offices and other facilities furnished with computer equipment and other sensitive electronic devices demand effective lightning protection to assure reliable operation. Surges in the power system induced by a lightning stroke can cause equipment malfunction or the introduction of false data or commands. Also, lightning-generated electrical energy levels are extremely high and can cause significant damage to electronic components. Such damage can occur when the equipment is turned off, and in some instances, even when it is disconnected from the power receptacle.

a. When lightning strikes a power line, there is a zone extending to each side of the actual stroke where the lightning voltage may greatly exceed the insulation level of the line, and flashover to ground will occur instantaneously. Simultaneously, traveling waves are generated in the conductors on either side of the strike point. These traveling waves have two components: voltage and current. The voltage magnitude is equal to the current magnitude multiplied by the surge impedance of the line and less than the flashover voltage of the system insulation. These surges travel along the overhead line at about 1000 feet per microsecond (the speed of light). Research shows that a lightning stroke produces more energy than has previously been considered possible. A typical lightning stroke carries nearly 3000 million kW at approximately 125 million volts and an average current of over 20,000 A.

(1) A typical lightning surge has an extremely steep wave front, which means that its voltage is rising at the rate of millions of volts per microsecond. The steep wave front is followed by a short wave tail, which means that after crest voltage is reached; surge voltage diminishes to half crest value in about 50 microseconds and completely dissipates in 100 to 200 microseconds.

(2) The development, testing, and correlation of insulation with lightning protective devices has been facilitated by adoption of a standard 1.2 x 50 voltage wave as representative of impulse surges. In the 1.2 x 50 microsecond's wave, crest is reached in 1.2 microseconds, and the wave decays to half crest in 50 microseconds.

(3) High-voltage testing laboratories have developed surge generators that can simulate lightning strokes. Not only have the 1.2 x 50 microsecond's waves been produced, but the generators can also produce the steeper-front waves with which arresters are tested for front-of-wave sparkover (as specified by standards).

(4) While lightning is usually considered synonymous with extremely high voltage, it is the current component in the lightning stroke that is the measure of its effect on a stricken object. The instant a voltage-sensitive device such as a surge arrester sparks over; it becomes a current-carrying path or relatively low impedance for the duration of the surge discharge. Major segments of the arrester's protective characteristics are determined by its performance in discharging the surge current.

(5) Elaborate scientific investigations have been made to measure and record lightning stroke currents. A wide range has been reported, varying from lows of 1000 A to highs of more than 200,000 A, emphasizing the unpredictability of lightning.

(6) Overvoltage surge protection for power lines and equipment can be devised by using arresters or by a combination of shielding and arresters. Because of the unpredictable nature of the lightning phenomena, engineering analyses are based on statistical data, and reasonable service continuity can usually be assured through correlation of scientific investigations, available weather records, such as isokeraunic maps, and appropriate protective equipment.

b. To provide the most effective safeguard, a lightning-protection system must be appropriate for the type of structure and its construction characteristics. Three protection systems are available and each should be considered:

(1) A conduction system has been in use for many years.

(2) An attraction technique has recently been gaining popularity.

(3) A dissipation system is another new method available.

(4) Other factors that must be considered in providing lightning protection for sensitive equipment include making sure that all parts that carry a lightning electrical discharge are located far away from items being protected. Extensive design data and installation guidelines for lightning-protection systems are provided in National Fire Protection Association (NFPA) 780-1997, "Standard for the Installation of Lightning Protection Systems;" the Underwriters' Laboratories (UL) 96A "Master Label Code;" and the Lightning Protection Institute's (LPI) LPI-175 "Installation Code." Isokeraunic maps also provide essential information on lightning frequencies.

c. The oldest and most commonly used protection method is the conduction system, sometimes termed as the Franklin Rod or Faraday Cage system.

(1) Air terminals (lightning rods) on the structure roof are connected to a grid of interconnecting (coursing) conductors, which connect to down conductors that extend down to earth and connect to appropriate grounding electrodes. The grounding electrodes can be individual ground rods or a conductive ring buried around the building perimeter or both.

(2) All system components are made of copper, anodized aluminum, or stainless steel.

(3) To complete the conventional lightning-protection system installation, all metallic elements (roof fans, vents, etc.), grounded or isolated, which are located on the roof or in the exterior walls near the down conductors, must be bonded to the down conductors because the possibility of a sideflash exists. A sideflash is an arc caused by a difference in potential between a down conductor and a metallic element. The bonding eliminates potential difference and prevents high current flow from damaging these components.

(4) Recent changes in standard guidelines have redefined the outline of the zone protected by any one standard air terminal. Originally, the accepted standard indicated that the area protected was defined by a 60° cone starting at the tip of the air terminal, surrounding the terminal, and extending to earth, without regarding the terminal height. Now, however, research and better data define the protected zone as an area under an arc that has a maximum radius of 150 feet and is tangent to the earth while touching the tip of an air terminal.

(5) This is important for structures exceeding 150 feet in height because additional air terminals must be installed at an appropriate intermediate level, as well as at roof level.

(6) Other protection requirements for high-rise buildings include the electrical interconnection of the steel column components or installation of conductive loops around the building at vertical intervals not exceeding 60 feet. A bonding conductive loop must also be made at ground level and at roof level. Furthermore, all grounded building elements (roof fans, vents, etc.) within 12 feet of the main roof must be connected to the protection system. Also, buildings over 75 feet high must use larger system components per the requirements of the Lightning Protection Code, NFPA 780-1997.

d. There are several other lightning protection systems commercially available on the market, but none are more effective than the Franklin Rod system.

e. Only lightning protection systems that meet the requirements of the lightning protection code NFPA 780-1997 are recommended.

f. To provide effective protection, it is of utmost importance that these three systems have a low-impedance path to ground. This applies to all components and connections from the air terminals to the grounding electrodes. Low impedance is essential so that the huge currents involved will follow the design path in preference to alternative paths offered by building materials such as wood, brick, tile, stone, or concrete. When lightning follows these higher impedance paths, extensive damage may be caused by the heat and mechanical forces generated during the passage of the lightning discharge.

(1) A low-impedance path reduces the potential difference between the storm system, the earth, and the protection to the point where a stroke does not occur or at least is somewhat controlled. Even with installations built on solid rock, an extensive low-impedance ground electrode/system is required, as well as solid connections between components and earth. Standards do not call out a specific ohmic ground value; however, every effort must be made to obtain the lowest value possible.

(2) A number of techniques can be used to lower earth resistance or provide an effective grounding network, as described in NFPA 780. Two additional effective methods for reducing earth resistance are achieved using chemical soil conditioning.

(3) Where the soil is of a high-resistance composition, calcium or sodium chloride has historically been buried with the grounding electrodes to increase conductivity. However, with this technique, the conductor and the salt usually require replacement every few years. To reduce the labor and expense required to make this replacement, a chemically filled rod has been developed.

(4) A second ground conductivity enhancer is a plastic-like material that is poured over the grounding electrode system before it is buried. This enhancement technique reduces the potential difference between the electrical system grounding path, the building structure, and the earth.

g. Interconnecting conductors are as important as other components. Tests in high-voltage laboratories demonstrate that a steep voltage wave front, such as created by lightning, causes the surge impedance in conventional conductors to increase to the point that side-flashes occur. Installation of multiple grounding conductors for buildings and a roof grid system creating a Faraday Cage reduces the magnitude of current flow in any one conductor. However, sideflashes can still occur.

(1) Standard down conductors are usually large bare copper or aluminum stranded conductors that are constructed particularly for the lightning-protection industry. A recent advancement is a coaxial cable that reduces the surge impedance as well as flashover. However, this cable is more costly than other conventional conductors.

(2) The most effective lightning-protection system can be selected after a study of the isokeraunic (lightning frequency for the area), and an evaluation of the structure/site characteristics. Isokeeraunic maps and related data are available from NFPA 780.

(3) A computerized program has been developed that predicts site vulnerability, building area susceptibility, and the magnitude of the possible stroke. Typical inputs to the program are structure height, site height above sea level, storm probability from area records, and the building configuration. From this data, the probability, location, and magnitude of a strike on the building can be determined. The program's accuracy has been as statistically accurate as the input data. Using this approach, the best-suited protection system can be installed, and sensitive equipment can be located away from strike-prone areas.

h. Other methods are used to protect equipment from lightning damage. For example, over transmission lines, substations, or high towers, a protective shielding cable sometimes called a "skywire" is installed. It is a well-grounded bare conductor, usually mounted several feet above the conductors or equipment to be protected. When lightning strikes in the vicinity, induced voltage surges tend to be carried by the shielding skywire instead of the protected conductors or equipment. Lightning arresters and surge protectors are also used to provide protection. These devices, which should be UL listed, prevent lightning induced currents and switching surges from entering the electrical and distribution/voice/data system. These protective devices are connected between the protected system conductor and ground. Normally, they see an abnormally high voltage, such as would be caused by a lightning stroke, their resistance breaks down, carrying any high currents to ground. After the danger is over, normal high resistance is restored.

CHAPTER 8

INSTALLATION

8-1. Objectives of an information technology equipment facility

The objective of an IT equipment system is to provide accurate, reliable, and continuous data. This objective can only be achieved through the careful and intelligent design of all aspects of the complete IT equipment system. The purpose of this chapter is to ensure that the installation of the system is performed in such a manner that a continuous trouble-free service is achieved. Initial site preparation and proper installation procedures can prevent many of these related problems. Other power related problems can only be remedied through the proper use of the proper power line conditioning devices.

a. Environmental conditions play a major part in insuring that computer systems operate at maximum efficiency. Proper temperature control becomes very important. Variations in temperature lead to component thermal shock, resulting in excessive downtime. High particulate counts in the atmosphere contaminate and cause problems. Corrosives have short- and long-term adverse effects. Vibration in heavy industrial areas and 40-story plus buildings must be observed and considered. Radio frequency interference (RFI) must be detected and prevented, as is the case with electrostatic discharge (ESD).

b. The personnel responsible for the design, installation, startup, maintenance, and operation of an IT equipment system must possess a high degree of knowledge in many seemingly unrelated fields. They not only must have a wide ranging technical ability but must also have a background in bid documents and interpreting specifications.

8-2. Contract bidding

The general philosophy of the contract bidding process is one of competition. Originally the idea was to give everyone a fair chance to compete for contracts but with competitive bidding to keep the vendors honest and provide the lowest price possible. The procurement methodologies grew around this conception and were designed to produce open and honest competition for all purchases.

a. It soon became apparent that finding the lowest bidder was neither appropriate nor practical for all procurements. There are many cases where it was absolutely necessary for an executive decision to determine which bidder was truly capable of providing the required product or services that would fulfill the client specifications in an acceptable manner. Experience demonstrates that in many cases the product or services of the low bidder may be simply unacceptable.

b. The specifications that are furnished to the bidders are the technical requirements of the end product and also as important, these specifications become the legal framework of a contract between vendor and client. The bidders are provided a detailed description of what must be supplied and are cautioned to bid realistically because their product must pass the scrutiny of inspectors that are knowledgeable and expert in their fields. The bidder must be aware that failure to fulfill the terms of the specifications may result in rejection of the product. Under these circumstances the contractor offering the lowest bid to produce that which has been clearly specified is awarded the contract.

c. Throughout the installation of an IT equipment system it is absolutely mandatory that the inspectors and engineers assigned to the project become familiar, proficient, and expert in understanding the bid specifications and the construction specifications.

d. The IT equipment manufacturer must submit in its proposal an item-by-item detailed compliance statement to all requirements of these specifications as well as complete floor plans, one-line diagrams, bill of materials, and all the data requested in the various parts of these specifications. The requested data should be presented on the specification compliance forms in the proposal. One-line diagrams must specify type, frame, and trip ratings of all circuit breakers. Floor plans shall identify all proposed equipment with weights, dimensions, access, and cooling requirements. Presentation of equipment not in full compliance to this specification must not relieve the successful bidder from meeting all requirements of this specification at no extra cost to the owner after the award of contract.

e. In the event of discrepancies between the drawings/attachments and the technical specifications, the technical specifications shall take precedence.

f. Off loading, setting in place, installation, interconnection cables, hardware, lugs, and testing of all equipment specified are to be the responsibility of the contractor including any and all associated labor, parts, tools, and equipment.

g. The final acceptance is to be made after the equipment has been adjusted and has demonstrated (site acceptance test) that it fulfills the requirements of the specifications and the supplier has furnished all required test documents in accordance with the specified testing procedures (see TM 5-694, Commissioning of Electrical Systems for C4ISR Facilities).

8-3. Inspection requirements

Installation inspection may be listed under the very broad heading of construction management. The inspector has the responsibility of being the eyes and ears on site throughout installation and should possess skills in many disciplines of engineering and construction. It is strictly the responsibility of the installation inspection individual or team to make certain that he receives the opportunity to evaluate all factors throughout an installation. The inspector must carefully determine the requirements and present appropriate and valid information to the other members of the construction management team.

a. The ultimate and final responsibility for a completed, one-line installation will rest upon a single agency or with an individual within that agency. The responsibility of the personnel performing startup inspections and verifying the compliance of the completed system with the specifications cannot be overemphasized.

b. Although there is considerable similarity in the design of all electrical apparatus associated with an IT equipment installation, there can be extreme variations in design tolerances, mechanical and electrical settings, and other physical characteristics.

c. Many quality features are now built into equipment, some of which add to the apparatus cost, principally because the manufacturer must protect his product from abuse and failure in normal use. Even though a system has been properly engineered and quality apparatus of the specified rating has been purchased, the equipment will ultimately experience premature failure if the proper installation and startup procedures are not adhered to. Reliability can be built into a system but proper installation is the key factor in initiating a proper equipment life cycle.

d. Many unknown and sometimes hazardous conditions are discovered through installation inspections. At times a simple and apparently minor adjustment can be made during installation which if found in time may benefit both client and vendor.

e. From the viewpoint of economics, the inspection process cannot and must not be allowed to degenerate into complacency. Assumptions cannot and must not be tolerated, and one must not assume the vendor or contractor possesses all of the necessary experience to complete a successful installation. It is the responsibility and duty of the purchaser and user to ensure that all equipment is installed so as to fulfill the concept of the design and to produce a reliable finished product.

f. The inspector or inspection team must make certain to continue to develop his expertise to enable him to carry out the responsibilities assigned to him. Inspection personnel must be able to work closely with both vendor and with those in authority within his own organization. The need for attention to detail cannot be over emphasized. In summary, it is the inspection staff that will carry the responsibility for maintaining a high standard of construction and start up of any project.

8-4. Ground system installation inspections

The earth ground system is a direct conducting connection to the earth or a body of water serving as a low impedance path to earth for the purpose of establishing an earth reference for the X0 terminal on the secondary of a transformer and for the purpose of providing a low impedance path for the discharge of lightning. The National Electrical Code (NEC) requires that the resistance to ground (earthing impedance) be less than 25 ohms (NEC Article 250-56). The grounding electrode conductor must be minimum No. 8 AWG copper or as shown in Table 250-66 of the NEC. The earthing impedance for a computer quality installation should be less than 5 ohms, and the earthing conductors should be the same AWG size as the supply conductors connected to the transformer secondary. The earthing electrode should penetrate the earth to a depth of 8 feet below the frost line and the earthing conductor must be connected to the earthing electrode with either cad-weld, silver solder, or a terminal block clamp located below ground level. Use of a saddle clamp is unacceptable as it will loosen with age, freezing, thawing, etc.

a. Doubling the diameter of an earthing electrode will decrease earth impedance by 10 percent, while doubling the length of a ground rod will decrease earth impedance by up to 40 percent. The most cost-effective and common method, however, is generally multiple electrodes. A technique of multiple electrodes spaced a minimum of 6 feet apart is the most effective. When the existing service entrance electrode cannot be measured (not able to shut building down), a second electrode should be driven 6 feet from the service entrance electrode. If earth impedance of the new electrode is less than standard, the service entrance electrode and the new electrode should be tied together with the same size conductor as used to connect the original electrode to the service entrance. If the second electrode impedance is above standard, drive a third electrode. Tie these two electrodes together with the same AWG wire used to the service entrance (No. 8 AWG minimum). Measure the impedance to earth. Continue this process, encircling the original electrode, until the standard is achieved. Then tie earthing electrodes to the original electrode as above. New electrical grounding test equipment is now available that can measure the ground resistance without disconnection of the earthing electrode and shutting the building down.

b. There is a difference between a neutral (grounded conductor) and ground (grounding conductor). The neutral carries current back to the source (transformer). A separate non-current carrying grounding conductor is also required to meet the NEC requirements for safety. This equipment grounding conductor is required to bond equipment frames to ground and to carry any fault currents to insure circuit breaker trips under fault conditions. On delta connected systems always insure that a separate ground wire is run

to bond equipment frames to ground. Additionally, a separate, full-sized, non-current carrying, insulated conductor (back to the transformer earthing electrode) may be required to provide a zero volt system reference point for IT equipment (see paragraph 4-6). This single point grounding conductor is used to connect the IT equipment signal ground to the electrical service entrance point and is required by the NEC.

8-5. Neutral junction installation inspections

Neutral is the junction point on a wye circuit or the center tap on a split-phase circuit. The neutral conductor provides the return path for current from the load to the supplying transformer. The neutral conductor is connected to the grounding electrode system by a grounding electrode conductor. This connection may be made at any location between the source terminals (typically a transformer or generator) and the first disconnecting means or overcurrent device. The neutral is then bonded to the equipment grounding conductors at this same point.

a. The neutral wire cannot be used for safety grounding. In the NEC, the neutral is referred to as the grounded conductor, while the safety ground is referred to as the grounding conductor. The grounding conductor (green wire) is the non-current carrying conductor (Section 250-26 of the NEC) and should carry zero current, except for any ground fault currents and for the discharge of static electricity. Underwriters' Laboratories (UL) approved or listed equipment does not cause current to flow in the ground conductor. The neutral conductor may never be connected to the grounding conductor in any circuit breaker panel except the main entrance panel (Section 250-24). The neutral conductor should never contact conduit or circuit panel cases. Connecting the neutral to ground in breaker panels causes the ground to operate as another neutral. This violates the code and is a safety hazard and can be a primary contributor to ground potential differences in a building. More than one neutral to ground connection will result in excessive ground current.

b. The only place ground and neutral can deliberately be tied together is at the building entrance distribution panel and on the secondary of any distribution transformer, including isolation transformers.

8-6. Safety ground installation inspections

Grounding accomplishes several purposes and safety considerations must take precedent whenever there is a conflict of interest. The task to be accomplished is to make the installation as safe as possible and at the same time satisfy all practical requirements for noise emission and susceptibility. The three basic purposes of grounding are safety, logic reference, and shielding. Safety falls into the categories of limiting "touch" voltage and providing a return path for fault current to ground. Logic reference provides a zero volt system reference for power supplies and shielding protects the electronics from high frequency noise.

a. Safety ground is an alternate path for the return of fault current for the purpose of interrupting (tripping) the branch circuit breaker and for establishing a point of reference to X0 terminal of the transformer. This conductor should be sized with the ability to handle the appropriate current to permit tripping the branch circuit breaker in the event of a fault. The impedance from any outlet to the transformer X0 terminal shall not exceed 2 ohms at 120 volts ac, 1 ohm for 240 volts ac, 0.5 ohm for 480 volts ac, etc. A clamp-on ammeter on the ground conductor should read near zero. Any reading in excess of 0.2 A should be cause for concern and the reason for this excess current should be found and eliminated. Earth ground and safety ground should touch only at the X0 terminal.

b. Any fault or leakage between an ungrounded conductor and a grounded enclosure will produce fault current. Leakage current may be harmlessly drained away, but a short circuit current must be

promptly terminated by protective fuses or circuit breakers. The same devices which protect against line-to-line or line-to-neutral faults also protect against line-to-ground faults. Therefore, the ground return path must have a low enough impedance so as not to limit the fault current to a value that will prevent prompt tripping of the protective device. The electrically continuous conduit and equipment ground conductor must be connected directly to the neutral of the power source at the building entrance neutral-ground bond. This is at a secondary of a transformer, output of a motor-generator (M-G), or at the building entrance service equipment if no isolating transformer is interposed.

c. The connection between the conduit or enclosure safety ground and neutral must not permit fault current to flow through a separate connection between the enclosure and a driven earth or other qualified ground connection. If fault currents have to pass through two driven earth stakes or rods, the resistance of these earth grounds would prevent many circuit breakers from tripping. A very low ground resistance for a driven earth ground might be 5 ohms (25 ohms is often acceptable). Two such earth grounds in series would be 10 ohms and when in series with a 120 volt ground fault would allow only 12 A of current to flow. This is not enough current to trip the lowest circuit breaker rating in common use, a 15 A breaker.

d. To ensure prompt operation, a circuit breaker must see from five to ten times its rated current. Ground path impedance between the fault point and the connection to neutral, plus all other circuit impedances, should not exceed 0.8 ohm for a 15 A circuit breaker (to meet a times ten criteria). For a 150 A circuit, this would be 0.08 ohms maximum. It is clear that driven earthing rods cannot meet this requirement, but direct wiring connections can.

e. Connecting some equipment to one ground rod and other equipment to a separate ground rod is a violation of the NEC and will create noise currents and voltages between the two rods. These ground loop currents result in noise on computers and other electronic systems and their interconnecting data cables.

f. The predominant type of grounding in Europe and the United Kingdom is the “TN” system. Like the method used predominantly in the United States and Canada, this scheme uses a grounded power source with the frame of the load grounded directly through a separate safety ground conductor to the neutral at the power source.

g. The ground conductors connect equipment frames to safety ground and to each other to limit the voltage that can be present on the frame of a product to a safe level to protect personnel. The voltage difference between the ends of a safety ground conductor should never exceed a fraction of a volt at power frequencies (50 or 60 hertz) except during a fault to ground condition and then only until a protective circuit element (circuit breaker or fuse) can interrupt the power from the source. Such a ground fault might be the result of either insulation or component failure in the equipment or a failure in the conductors supplying power. The conduit and grounding conductors are not intended to carry any portion of the load current. They are to carry only fault currents, leakage currents, and noise currents.

h. At power frequencies, 30 volts root mean square (RMS) is commonly specified as an upper limit for “safe” voltages. A momentary excursion above this during the time it takes for a fuse or circuit breaker to clear a fault is not considered a significant hazard.

i. At higher frequencies and with short duration impulses, the human body can tolerate much higher voltages and currents than at power frequencies. This is fortunate because as frequency content increases, the voltage drop for a given leakage or noise current also increases. High frequency and impulse voltage signals of 150 to 200 volts appear regularly on ground conductors associated with 120 volt circuits. Their duration, however, is usually measured in microseconds and they cannot normally be detected by touch.

j. The most important consideration for computer reliability and operation, as well as other electronic systems is a simple point ground reference within its environment. The computer system's reliability will be enhanced by using this technique. The building service entrance should be the initial reference for the single point ground system or even more desirable is the reference for the computer system's treatment device.

8-7. Inspecting for unbalanced loads

High or "noisy" neutral-to-ground readings can indicate a poor power balance between loads. Improperly balanced loads will cause excessive neutral current to flow, resulting in a voltage drop across the neutral conductor. Balancing the loads should reduce this current/voltage and if it does not, the neutral-to-ground bond should be checked, and the grounding conductor size and insulation verified. Where the major portion of the load consists of electric discharge lighting, information technology equipment or similar equipment, there will be harmonic currents present in the neutral.

8-8. Utility power systems installation inspections

American utility companies attempt to maintain electrical power within certain tolerances. See Section 2-2.b. for a discussion of typical values.

a. In addition to the voltage and frequency tolerances allowed by the utility supplying the IT system, there are six basic power line problems to be considered when inspecting an IT installation.

(1) No voltage (loss of power) is very easy to detect. No instrumentation is required, only attempting to turn on the lights or some piece of equipment. Causes can range from downed power lines to failed transformers, to tripped circuit breakers, etc. These power outages may last for a short one-half cycle of the 60 hertz sinewave (8.3 milliseconds) or for several hours. Most are no longer than a few seconds.

(2) High or low voltages/amplitude changes in the sinewave can be detected with a voltmeter or a voltage recorder. Causes may be power lines, distribution panels, and/or the wiring being too heavily loaded. In addition, being too close to the source of the power or too far from the source of power can cause large voltage fluctuations, as well as starting or stopping heavy motor loads, non-uniform loading of poly-phase transformers, or poor regulation. If these conditions continue for more than 8.3 milliseconds, but less than 2 seconds they are high or low voltage line conditions, often referred to as high-average or low-average line voltage.

(3) Harmonic distortion refers to sinewave misshaping caused by harmonics (multiples) of the primary frequency. When 60 hertz power is generated, inherently all the odd harmonic frequencies (180 hertz, 300 hertz, 420 hertz, etc.) are generated but only the 3rd, 5th, and 7th normally have sufficient amplitude to be of concern. Generally, these are so small as to go undetected except with very sophisticated equipment. Flat-topping of the sinewave, as seen on an oscilloscope, is the first indication of harmonic distortion. High neutral current is also an indication of excessive harmonics (3rd harmonics). Causes may range from overloading or improper loading of transformers, faulty regulation transformers, fluorescent or other electric-discharge lighting, to information technology equipment.

(4) Noise is normally detected as bad or faulty data and is investigated with an oscilloscope. Oscilloscopes are used to detect and analyze high frequency events or even to analyze the 60 hertz power sinewave. Noise is a low voltage, low current, high frequency signal riding on the 60 hertz sinewave and is characterized by having a repeatable frequency pattern, one that can be determined and analyzed. Generally it is electromagnetic interference (EMI) and is caused by having the power or data lines or the

equipment too close to a source of EMI; a large motor or transformer for instance. Improper grounds or grounding can also be a cause. Noise can also be RFI if a radio tower or transmitter is located nearby.

(5) Transients or impulses are high voltage, high-current, fast bursts of energy riding on the 60 hertz sinewave. They also exhibit a non-repeatable frequency pattern even when resulting from the same repeated event. They exhibit extremely fast rise times (one microsecond to peak) and last for less than 8.3 milliseconds, usually decaying to 50 percent of peak value in 1 millisecond or less. Because they have no repeatable frequency pattern and are random in occurrence, they are extremely difficult to detect. Power line analyzers must be used to detect the presence of transients although the first indication of their existence is usually data errors, computer crashes, and damaged circuitry. Microprocessor based equipment is very susceptible to damage from these anomalies. Transients occur whenever the current through any inductive load (motors, transformers, coils of any kind) is changed at a rapid rate. The result is a voltage impulse that follows the equation, $-E = L di/dt$. This rapid change in current is the result of switching actions, sudden power outages, and applications of power. Transients are also induced on power and data lines by nearby lightning strikes or have data lines too close to power lines that are being switched.

(6) Finally, the sixth of these anomalies and the most common one is any combination of the above. While any of these problems can and do occur by themselves, the more general rule is for them to occur in combinations. Transients always accompany voltage outages. High or low voltages may result in noise when power supplies are put under the strain of having to work at input voltage levels outside their design limits.

8-9. RFI inspections

RFI is any emission of electromagnetic (EM) energy having an undesirable effect on other electronic equipment. As electronic IT equipment has become more sophisticated and dependence on the continued on-line operation of this equipment has grown, the effects of RFI have become more prevalent.

a. Although RFI of sufficient levels can adversely affect most electronic circuitry, among the most susceptible are disc drive positioning circuits and plotter mechanisms; as little as 1.0 volt/meter can be harmful to this equipment. The necessary sensitivity of these circuits makes them susceptible to extremely low level interference unless they are adequately shielded. Due to the necessity for special instrumentation to detect EM radiation and its possible presence in practically any location or environment, it is imperative that RFI susceptibility specifications for all IT equipment are published by the manufacturer and that an RFI survey be included in all site preparation surveys for proposed systems locations.

b. Regardless of location, urban or rural, industrial or residential, sources of RFI abound. Some of the more prevalent sources of RFI are:

- (1) Radio transmitters
- (2) Radar transmitters
- (3) Aircraft navigational equipment
- (4) Microwave ovens
- (5) Automobile ignition systems

- (6) Induction ovens
- (7) Diathermy equipment
- (8) Relay operated equipment
- (9) Electric motors
- (10) Radio receivers
- (11) Television receivers
- (12) Furnaces
- (13) Home appliances
- (14) Switching contacts
- (15) Other electronic equipment

c. These devices can appear at any time before or after the installation of IT systems, without any noticeable change to the environment, adding to the subtlety of failures induced by the effects of undersized EM radiation. A survey for RFI presence may save considerable time and duress when troubleshooting recurring intermittents and failures without apparent cause.

d. A survey of the vicinity will reveal a transmitting tower, or a check with occupants in nearby facilities will indicate other interference problems. In any case, a survey utilizing appropriate instrumentation is recommended when interference is suspected.

e. Many commercially available instruments can be utilized in performing the survey. Field strength meters, electronic field sensors, spectrum analyzers, and the electronic oscilloscope are most common. The spectrum analyzer is the most sensitive and accurate device to locate the presence and identify the source of RFI. Tuning the spectrum analyzer over the band will indicate the relative levels of radiation as well as its frequency. A portable electronic field sensor should be used to check for areas of increased or decreased field strengths once the source has been identified.

f. To begin a survey, first make a plan drawing of the location indicating all windows, doors, furniture, and equipment. Near the affected equipment, set up a spectrum analyzer and record all frequencies indicated with their respective power levels. Using the portable electronic field sensor, observe the field strength present at the affected equipment and record the reading in volts per meter on the respective location of your plan drawing. Now record several readings within the location using the portable sensor.

(1) Record the field strength outside the building on each side and try to identify the source of any interference by noting the direction of strongest readings.

(2) Compare all recorded field strengths to the published equipment specifications and note any readings that are excessive.

(3) Should you not have the necessary instrumentation, and the interference is from a radio or television broadcast station, the following method may be used to determine field strength.

- (a) Obtain the station's radiated power from the station engineer.
- (b) To determine the approximate field strength use the formula:

$$E = \frac{(30P_t)^{1/2}}{d} \text{ volts/meter}$$

Where: E = field strength in RMS volts/meter
 P_t = transmitted power in watts
 d = distance from isotropic antenna in meters

This calculation does not account for any insertion loss resulting from walls, buildings, etc.

(4) If it is suspected that interference is occurring sporadically or only at various times, a strip recorder can be connected to the E field sensor and left to record field strength over several days.

g. The methods chosen to eliminate RFI problems will depend on the physical characteristics of the site as well as the field strength present. Some interference problems may be corrected by simply providing a separate grounding connection to the frame or case of the affected equipment or moving equipment to another room. More serious cases may require the purchase or construction of a completely shielded enclosure incorporating filtered power and shielded ventilation.

h. In some cases, it is recommended that all walls, ceiling, floor, doors, and windows be shielded. The shielding material should be bonded at all seams to ensure maximum effectiveness of the shielding. The shielding material should then be connected to a good earth ground. This treatment can provide as much as 80 decibels (dB) attenuation at 100 megahertz (MHz), when door sealing and ventilation duct shielding have been provided. Attenuation by 80 dB will reduce field strengths to one ten-thousandth of their former levels.

i. RFI problems are primarily solved with Faraday Shielding and special window glass like that used in microwave ovens. When shielding of the entire room is required, run a No. 12 AWG bare copper wire around the bottom of the shield, solder it to the shield, solder the shield together and reference the shield to the transformer ground (X0). An RFI detector reading of one-half (1/2) volt per square meter to 1 volt per square meter is the maximum allowable.

j. Never place electronic equipment closer than 3 feet to fluorescent lighting due to the RFI radiation from the lamps.

8-10. Electrostatic discharge (ESD) inspection

ESD is a transfer of charge between bodies of differing electrostatic potentials. The term ESD event also includes both EM fields and corona effects before and during a discharge. The ESD event may include significant electric (E) and magnetic (H) field phenomena due to current flow. ESD phenomena thus include EM field generation over a broad range of frequencies, from dc to the low gigahertz region.

a. One of the subjects may be fabricated electronic equipment or subassemblies. This subject is generally at local electrostatic ground potential. The second body, usually in the role of an intruder, is often a human; but it may be any mobile object such as a wheeled chair, an equipment cart, a vacuum cleaner, etc. The victim may also be affected by the EM fields generated by a discharge between an intruder and a third mass which is not itself the subject.

b. Static electrification refers to all processes which produce segregation of positive and negative electrical charges by mechanical action. These processes operate by contact between two surfaces with subsequent separation.

c. The most common charging mechanism is frictional or tribo-electrification. This mechanism involves electron or even ion transfer upon contact due to the frictional localized heating of microscopic contact between solid surfaces. The localized microscopic zones are fluidized, leading to increased charge mobility. Accumulation of charges can occur if the relaxation time or charge decay is long due to low conductivity values.

d. The distinction between a conducting and a non-conducting object is based on its surface resistance in ohms-per-square centimeter. A non-conductive object cannot be discharged by grounding points on its surface. The electrostatic charge that can be developed between two materials is a function of their relative position in the tribo-electric series. The term tribo-electric derives from the Greek “tribos” meaning to rub. Hence, tribo-electric is the generation of static charge by rubbing.

e. Everyday actions can develop large electrostatic potentials due to static charging. As a typical example, walking across a synthetic fiber carpet on a relatively dry day (30 percent relative humidity) can easily develop an electrostatic potential of 20 kV or more. The floor need not be carpeted. Walking across many present day floor coverings can also produce an electrostatic charge. Waxing the floor may worsen the situation, adding to the electrostatic charge that may be developed. Simple movement of the body within clothing can also develop large static potentials. At 15 percent relative humidity, walking 20 feet on a vinyl floor, the human is charged to 12 kV, whereas at 80 percent relative humidity, the human is only charged to 1.5 kV. Walking on a carpet at 15 percent relative humidity, the human can charge to 35 kV.

f. The minimum voltage necessary for a person to detect an electrostatic discharge is approximately 300 volts. However, sufficient energy may be contained in electrostatic discharges that are below the threshold of human perception to cause damage to electronic equipment. The maximum potentials that may be routinely developed via electrostatic charging ranges from one to 10 kV. Given the proper conditions, potentials may reach 20 to 25 kV. Corona effects, which bleed off charge, limit maximum electrostatic potentials to 35 to 40 kV. The electrostatic potential difference that exists between two charged objects, or between a charged and uncharged object, may be viewed or modeled as existing between two plates of a charged capacitor. In the extreme case, human body electrostatic discharges may contain energy levels as great as 400 millijoules for voltages of 40 kV and a capacitance of 300 picofarads (pF).

g. Damage to equipment caused by electrostatic discharge can be minimized by placing grounded static discharge mats in areas where movable furniture (chairs, file racks, etc.) or pedestrian traffic can discharge into a sensitive component. Personnel working on sensitive equipment may need to be continuously grounded through a wrist strap. Equipment used in the maintenance of sensitive components should be grounded and special manufacturer maintenance procedures must be followed.

8-11. IT system environment inspections

Computers and other IT devices along with their peripheral equipment have very precise environmental tolerance limits. Therefore, the precise control of temperature, humidity, and particulate contamination is critical to their proper operation.

a. The ideal computer room environment is critical.

(1) Temperature should be adjustable from 65°F to 80°F but shall optimally be set at 72°F and not vary more than $\pm 1^\circ\text{F}$ from that setting. The temperature should not vary by more than 10°F anywhere in the room. Variations of the component temperatures, with time, causes flexing of the components, component leads, printed circuit boards, connectors, etc. Every time a junction or connection is flexed it is stressed and every time it is stressed it deteriorates.

(2) Humidity is also critical and shall be controlled within ± 2.5 percent R.H. over an operating range adjustable from 45 to 55 percent R. H. The ideal setting is 55 percent (± 5 percent) as there are minimum static problems at 55 percent relative humidity. Humidification is the only way to control static.

(3) The only acceptable form of humidification is with pure steam humidifiers designed for computer room environmental control. These offer the highest efficiency and lowest maintenance and the steam is distilled. Never use cold mist humidifiers that release water-borne contaminants into the computer room atmosphere. Wet bulb humidifiers with heating elements require continual cleaning of sludge tanks to keep them efficient. Evaporative and infrared methods can release corrosive salts, excessive humidity, and mineral contaminants directly into the computer room environment, eventually leading to computer system failures.

b. To help execute these parameters, the computer room should be constructed with wall insulation rated R-19 or better; floors and ceilings should also be insulated. All windows should be thermopane. All outside windows should have sunscreens and all glass above the 12th floor should be Faraday shielded. Airflow from the air conditioner should be designed to provide the maximum amount of mixing possible from the discharge to the return. Discharge should not be directly into the equipment to prevent thermal shock to components when air conditioner operates on and off. Equipment should be laid out to avoid creating any air dams; i.e., equipment in a line should have a minimum open spacing between individual products of 8 inches, and particulate producing equipment such as printers should be placed closest to the cold air return in the product lineup.

c. The computer room air conditioner should run almost all of the time to eliminate temperature cycling. Ethylene glycol coolant is best suited for meeting this requirement because it uses a smooth running turbine compressor; it can be easily regulated, and has a heat transfer 1 to 1.6 times that of water, depending upon the ratio of water to ethylene glycol. However, to use ethylene glycol, a 24-hour chilled water loop is required. If ethylene glycol cannot be used, then use Freon. However, Freon cannot be throttled and will result in more frequent temperature cycling.

(1) The advanced A-frame air-conditioner arrangement with cross-circuited cooling coils connected to two separate refrigeration systems under electronic sequencing control provides greater sensitivity in cooling and dehumidification. Greater surface area and lower velocity air offers quiet, efficient cooling with less turbulence. This system enables 60 percent cooling to continue during servicing of one of the refrigeration systems.

(2) The air-conditioning unit should have an electric resistance heater sized to offset the sensible cooling capacity in the dehumidification mode. The reheat element should be of low-watt density, tubular construction with a no-corrosive metal sheath. The electric reheat should be three-phase system identical, to prevent the possibility of uneven phase balance. The reheat element should be electrically and thermally protected in accordance with UL requirements. Both heating and cooling functions should have automatic step starting (or variable frequency drive) with time delay to minimize power line

requirements. Temperature and humidity sensors should be solid-state devices to ensure accurate system control and high reliability.

(3) When evaluating the air-conditioning system it is desirable to have a high coolant pressure differential across the compressor, but, a high delta P across the evaporator causes freezing and is an indication that either the dryer is dirty or the airflow over the evaporator is insufficient. A check of feeder line amperage gives a good indication of the continuing health of the air conditioner. A drop in current from previous readings indicates a loss of Freon.

d. Computer room air must be filtered to 15 microns or less. The newer disc drives require 10 micron filtration. Electronic filters must be equipped with Faraday shielding, have internal water jets for wash-down cleaning and address smoke, hydrocarbons, and particulates. Air supply shafts must have Faraday shielding because spark gap precipitators generate frequencies in the gigahertz range. Particulate count must be less than 150 parts per liter, chlorine count less than 10 parts per billion and sulfur count below 10 parts per billion.

8-12. Pre-site inspection

Computers and other electronic systems are often adversely affected by the environment in which they are located and expected to function. Variations in temperature will stress solder joints and contact points due to the variations in the expansion and contraction characteristics of the different materials involved; i.e., fiberglass, plastic, metals, etc. If the humidity is too low, static becomes a problem; too high, and things begin to grow. Chemicals in the air can corrode and airborne particulates can be conductive or abrasive and affect circuit boards and the operation of electronics, as do externally generated voltage impulse transients and noise.

a. To optimize operation, all of the above areas must be considered and dealt with and the problems eliminated. Ideally, this should be done prior to the installation of the computer or electronic system. Practically, however, these areas are very often not properly addressed until after installation and the equipment operation begins to suffer, thus causing attention. Whether addressed prior to or after installation, the physical steps taken to insure the best possible site preparation should be nearly the same.

b. Begin a pre-site inspection several miles from the site and always involve as many of the following personnel as possible – the salesman who sold the equipment, the IT equipment manager, maintenance manager, building contractor, air-conditioning contractor, and electrical contractor. Within a five-mile radius of the site, note the general terrain, other industries in the area and their types, antennas, transmission lines, etc. Determine whether the power is brought into the facility underground or overhead. Note everything, even the prevailing winds. When arriving at the site, view the building from all sides and especially from the roof.

8-13. Pre-inspection for electrical systems

Perform the electrical inspections with the electrical contractor or the electrician. Start at the building's main service entrance.

a. Find and verify the earthing electrode installation.

b. At the transformer, check for any contamination, corrosion, or leakage; check the transformer temperature and insulation and the cooling fans, if any.

- c. Follow the power to the IT equipment or electronics room. Check all transformers as above. Observe all aluminum terminals for correct connections and connection integrity (listen and smell).
- d. Measure and record currents and voltages at each transformer and in the distribution panels.
- e. Check and record voltage across each circuit breaker and the current on each breaker.
- f. Check all neutral and ground wires for current.
- g. Verify the neutral and ground busses to be insulated and isolated. Verify that the voltage between the neutral and ground is no more than 0.2 volt RMS (1-2 volts peak to peak as measured on an oscilloscope).
- h. Check primary and secondary bus voltages and check for any ground to neutral voltages. Verify voltages and current and that the system is balanced. Check that wire sizes and breaker sizes are compatible.
- i. Verify that there is a neutral wire for each circuit breaker in the distribution panel; i.e., the same number of neutrals as there are circuit breakers.
- j. If the IT equipment is not yet in place, verify that it can be unloaded at the dock and moved to the final destination with a minimal risk of damage. Verify that equipment can be properly stored to protect it from the elements prior to installation. Verify proper clearances, stairways, elevators, door widths, heights, etc., so the equipment can be transported to its final location without fear of damage.

8-14. IT equipment room inspection

Inspect the computer or electronics room where the equipment is, or will be, located. The ac power for this equipment should be supplied from a transformer dedicated for this purpose and located as close as possible to this room. This transformer, and any isolation transformer, must have the secondary neutral solidly grounded. If the ac specifications for the equipment cannot be met, a line treatment device will also be required. All receptacles in this room should be the isolated ground type.

- a. The computer (electronics) room should not be a passage area; i.e., no convenient pathway from one area to another area. It should have a raised floor, minimum height 6 inches, with ramps rather than stairs into the room and be vinyl covered. Wash the computer room floors with Ivory soap and wet mop only. Use no ammonia (chlorine) and the floor should be one piece vinyl. Seal all masonry and have no glass or carpets on the walls.
- b. Raised floor posts must be painted, galvanized, or cad-plated to prevent rust. Permit no roller chairs in the room to prevent electrostatic discharge problems. All floor supports should also be grounded. This ground should be a “dirty ground” back to the isolation transformer X0. It is not to be connected to neutral or computer ground except at the transformer X0. This ground can be used for grounding of non-electrical items such as static mats, etc.

8-15. Air-conditioning system inspection

The room should have its own air-conditioning system. The air conditioner should be dust free. Electronic filtering is the optimum. The air conditioner should provide positive air pressure in the room to help keep out outside contaminants. There should be no corrosives in the room. Possible corrosives include ammonia, hydrocarbons, hydrogen sulfide, nitrates, oxides or nitrogen, oxidants, and sulfur

dioxide. Room temperature should not vary more than 10°F from hottest to coldest spot anywhere in the room and the overall temperature should not vary more than 10°F per hour. This can best be attained by using a chilled water coolant system rather than freon, as chilled water systems are easier to throttle, meaning less “on and off” operations. Humidity should be between 50 and 60 percent at all times. Equipment should not be positioned in a manner to create air dams. Provide a minimum of 8 inches clearance between any side-by-side devices. Note the intake and exhaust vents; they should be located to allow maximum air mixing in the room. If there are outside windows exposed to sunlight, some type of correction will be required to shade the windows.

8-16. Lighting system inspection

Lighting should be from 55 to 72 candlepower throughout the room, with the backs of all equipment receiving equal or greater lighting from the fronts. Place no equipment closer than 3 feet to any fluorescent lighting to prevent RFI radiation problems. It is more than likely that the fluorescent fixtures in a large business complex will be powered from a three-phase, four-wire system. Fluorescent lighting systems are non-linear loads and, therefore, are generators of 3rd harmonic currents. The recently developed electronic ballast consumes less power but has the decided disadvantage of injecting even higher levels of 3rd harmonic current into a power distribution system. It is essential that the special characteristics of these non-linear loads be understood to prevent the failure or disturbance to critical systems. Every part of the room must have telephone access through additional telephone jacks or long telephone cords.

8-17. Fire safety inspection

If fire safety is provided through a sprinkler system, a means should be provided to automatically disconnect the computer or electronics power when the sprinkler is activated. Due to restrictions on the emission of chloro-fluorinated hydrocarbons (CFC) to the atmosphere, Halon systems are being phased out. The next generation of clean agent fire suppression systems uses environmentally friendly products such as FM-200, a compound of carbon, fluorine, and hydrogen that is odorless, colorless, electrically non-conductive, and non-corrosive and leaves no residue when discharged. Since FM-200 is discharged as a gaseous vapor, it is able to penetrate enclosures and reach areas that water or dry chemical agents cannot. A fast response, automatic fire detection system is commonly installed to activate the suppression system and limit both fire and smoke damage. In most cases, photoelectric smoke detectors will be used due to the high airflow conditions found in IT facilities. Careful attention must be paid to airflow rate and how it impacts detector spacing. Aspirating (air sampling) smoke detection systems may also be installed in some facilities to allow detection during the fire's incipient stages.

8-18. Total evaluation

During the first site preparation walk-through, all the above information should be recorded, as taken, and stored. Every six months to a year, all information should be recorded again and compared to the previous and original data. In this way, the affects of added equipment can be evaluated and any addition of equipment that is not readily apparent or should not be on the dedicated system can be found.

a. Proper environmental instrumentation will help in collecting much of the required data. Instruments are available for monitoring: light levels (light meter), humidity (sling psychrometer or hydrometer), temperature (chart recorder), RFI (field strength meter), static (Anderson Effect Meter), vibration, and microbial contamination. If, however, these instruments are not readily available, a fairly thorough evaluation of environmental conditions can be made with an amprobe, a sling psychrometer, and the human eye. Green door hinges indicate the presence of chlorine; black or greasy door hinges result from hydrocarbons. Check air-conditioning vents for signs of corrosion and hydrocarbons. A white

powder on the printer is caused by chlorine and blackening of the leads of the dual-in-line packs (DIPS) and chips are caused by the presence of sulfur. A glass ashtray can be used to detect vibration. Place it on a smooth surface and clearly mark its location. Return in a few days and if it has moved, vibration is indicated.

b. Hydrocarbons and sulfur can be removed with an electronic air cleaner. Chlorine or a high concentration of sulfur will require a scrubber. Vibration difficulties can be handled by placing the equipment on four-inch thick cork mats. High noise levels may require special noise abatement procedures such as special acoustic wall covering, ceiling tiles, etc.

CHAPTER 9

MAINTENANCE

9-1. Objective

In most common electrical systems, two types of maintenance are normally recommended, routine and preventive. Routine maintenance is that which is required to ensure continued operation of the system and is usually that which is recommended by the equipment manufacturer. Preventive maintenance carries the routine maintenance one step further by performing actions, such as replacing components that may be nearing their end of life, that prevent failures of systems that would cause unwanted outages. Breakdown maintenance is the minimum level performed by all organizations and consists of those actions conducted after a failure to restore equipment or systems to an operational condition. The main objective of a preventive maintenance program is to reduce the number of avoidable breakdowns. A well-planned and efficient preventive maintenance program is expensive; it requires shop facilities, skilled labor, keeping records, and stocking of replacement parts. However, the cost of downtime may amount to ten or more times the actual cost of repair, and possibly compromised security and the problem cascading into related systems. Therefore, maintenance must be scheduled into the operation of any information technology equipment system that will be processing hard to replace or sensitive information.

a. When preparing maintenance schedules, it must be recognized that too frequent inspections are a waste of money and that insufficient inspections place vital equipment in jeopardy. The frequency of inspection should depend on the equipment's contribution to profitable production, its duty cycle, age, overload, and other pertinent factors. The manufacturer of electrical equipment will recommend an inspection cycle that may be modified later by experience. A good maintenance program provides for scheduling equipment out of service for routine overhauls during periods of least usage, rather than risk a breakdown at an inopportune time. Thus maintenance can be done at a time convenient to the production or operating schedule. Some companies find it convenient to close down completely during the vacation periods to provide time for planned overhauls.

b. All equipment should be classified as to its role in the manufacturing or operating process. Machinery and control equipment that could halt operations if a breakdown occurred should be classified as vital equipment and should be provided with a very comprehensive preventive maintenance program. Other equipment, such as room air conditioners, electric fans, drinking-water coolers, etc., should be classified as non-vital equipment. A breakdown of non-vital equipment will have little or no adverse affect on the processing of information or safety, etc., and a simplified maintenance program may be used. The decision to provide the same degree of maintenance for non-vital and vital equipment must be made with as much consideration as was given to the selection of the equipment itself. The cost of such programs should be considered as part of the unit cost of operation or production. The essentials of an effective preventive maintenance program include record taking and interpretation, acquisition of adequate replacement parts, skilled labor to carry out the program, and cooperative management.

c. It must be recognized that the deterioration of electrical equipment is normal, and this process begins as soon as the equipment is installed. If deterioration is not checked, it can cause electrical failures and malfunctions. Load changes or circuit alterations may be made without overall design coordination, which can result in improper settings of protective devices or wrong trip units installed in the circuits. With an electrical preventive maintenance and testing program, potential hazards that can cause failure of equipment or interruption of electrical service can be discovered and corrected. Also, the program will

minimize the hazards to life and equipment that can result from failure of equipment when it is not properly maintained.

d. The systems within an IT equipment facility may interface with one another, such as main electrical power; emergency power; dedicated “clean” power; utility power; fire and security systems hydraulic; pneumatic; heating, ventilation, and air-conditioning (HVAC); and other mechanical systems. Therefore, it is important to know how these interfaces work and how they can be coordinated in the maintenance program. Related systems within a facility cannot be overlooked. The air-conditioning and heating system that maintains temperature and humidity levels in an IT center can result in IT equipment failures if this equipment fails. HVAC systems produce a quality work atmosphere for IT personnel but more importantly the HVAC systems produce controlled conditions that are essential to reliable IT equipment operation.

9-2. Maintenance program

The main objective of planning preventive maintenance in an IT system is to provide quality power at a reasonable and acceptable cost.

a. This objective can only be reached by implementing a well-planned maintenance program that will:

(1) Improve overall plant and equipment productivity through continuous operation and production by reducing downtime.

(2) Minimize maintenance expenditures through budgeting for planned versus replacement cost by collecting data on equipment and production downtime.

(3) Establish maintenance priorities by analyzing equipment and production priorities.

(4) Stock replacement parts for high priority apparatus.

(5) Implement the best maintenance techniques and test equipment.

b. The era of growing old with equipment is over. Today, it is impossible for untrained maintenance personnel to keep pace with the continuous changes in electrical equipment being produced through advanced technology. Service and maintenance requirements for electronic and solid-state circuitry require a high level of specialized training and skill. The individual who is not given the opportunity, or is unwilling to update the educational requirements necessary for the maintenance of modern equipment, is faced with the possibility of being phased out along with the obsolete equipment being replaced. This is a reality facing anyone who is expected to service and maintain sophisticated and more complex apparatus.

c. Plans for a maintenance program should be one of the first considerations when a new plant is constructed, additions made, or more modern equipment purchases are installed. At this time, conditions are ideal for one or more of the maintenance personnel to inspect the normally inaccessible parts of equipment and to ask questions of the installing contractor or the manufacturer’s representative in order to learn as much as possible about the maintenance requirements for new equipment coming under their jurisdiction.

d. Total familiarity with the electrical equipment is a necessary prerequisite for any maintenance program to be successful, and an extremely valuable asset to rely on if it becomes necessary to correct or repair any operating problems within the electrical equipment.

e. The main parts of the maintenance program can be classified into maintenance management considerations, technical requirements, and those items that should be included in the electrical maintenance and test program.

(1) The design of any maintenance program must meet the ultimate goals of management. Maintenance is like an insurance policy: it has no direct payback, yet it is a cost that adds to the cost of the final product. However, one must hasten to say that it has inherent payback. It is generally observed that management resists the investment in a maintenance program even though they realize the need for good maintenance. In view of this, it is up to electrical personnel to show management how a properly planned electrical maintenance and testing program is justifiable.

(2) The planning of the programs should then include the advantages of well-planned maintenance along with cost data for lost production, security or mission. Any maintenance program should prove that it is cost effective and minimizes equipment failure. The planning of the program should include considerations for proper test equipment, tools, and trained personnel to carry out maintenance routines. Also, consideration should be given to record-keeping systems, which can range from fully computerized to manual file systems. To set up an electrical preventive maintenance and test program, the following steps may be undertaken.

(a) Determine the factors that will form the basis of the maintenance program, such as the necessity for continuous production, and management policy on budgeting for planned maintenance versus replacement of equipment.

(b) Survey and consolidate data on equipment breakdowns and cost of lost production. Make an analysis of the cost data to convince management of the benefits of planned maintenance.

(c) Establish electrical maintenance priorities. These consist of on-line production sequence, determining the most important to least important equipment, weighing the reliability of the equipment, and other factors.

(d) Establish the best maintenance techniques. This involves selecting the best maintenance method and personnel for the various types of equipment and systems.

(e) Schedule and implement the program. Monitor its benefits and costs. Analyze program functions periodically for improvement of the program.

f. After the program has been set up, it is essential that it consist of five elements that will prove it to be a success: responsibilities, inspection, scheduling, work orders, and record-keeping.

(1) The responsibilities of the maintenance organization should be clearly defined by organization charts with functional work statements for each unit. The functional work statements must be established by management as a matter of policy. Every other department must be informed of the responsibilities assigned to maintenance organizations. The effectiveness of the maintenance departments will depend upon how well they are organized and how well personnel are utilized.

(2) Inspection is the key to the success of any maintenance program. Sufficient time should be allocated for inspection to verify the condition of new and installed equipment. The purpose of inspection is to provide advance warning as to the condition of the equipment under investigation. When inspection is performed on definite cycles by qualified people, impending deterioration can be detected in advance so that repair or replacement can be made before failure of the equipment occurs.

(3) To perform maintenance, a definite schedule of work to be performed must be established. Maintenance schedules must be based upon minimum downtime for the various operating segments. The schedule for inspection, routine maintenance, and other work may vary for different equipment and will depend upon many factors. These factors can be age of equipment, frequency of service, hours of operation, environmental conditions, damage due to abuse, and safety requirements. Frequency of scheduling of the tasks should be adjusted as data on various equipment are recorded and analyzed to provide a balance between cost of maintenance and replacement cost of the equipment.

(4) Work orders are job requests that need action for completion. Work orders can be established for all inspection service and other work on equipment in terms of routines. Any of these routines should include information on when such work is to be performed, where it is to be performed, and exactly what has to be done. These routines can be generated by a computer-based maintenance system. The routines should include all the pertinent information concerning the equipment.

(5) The success of a planned maintenance program depends upon the impetus given by top management and the interest of the maintenance personnel in the program. To have an effective program, it is imperative that maintenance and test inventory data on all equipment should be complete and readily available throughout the service life of the equipment. To that end, record-keeping is very important. All forms and reports should be organized to provide ready accessibility to data when needed and to flag down problem areas. Such data may also be used over the years to analyze trends for equipment deterioration. If data is not recorded and maintained properly, the whole purpose of planned maintenance is lost.

9-3. Maintenance data file

The maintenance data file of the IT system will include the information relating to the hardware within a defined system, a list of maintenance personnel qualified to support the equipment, training records with the level of skills achieved, current data on manufacturers representatives, renewal parts vendors, consultants with a special field of expertise that is not available in house, and the service organizations on contract to maintain equipment.

a. The most important phase of a preventive maintenance program is the recording and interpretation of data pertinent to each piece of equipment. One method of data file record-keeping will use two or more file cards (or electronic file cards) for each piece of equipment. The equipment record card should include the motor nameplate data, location in the plant, purchase price and installation cost, application, and the manufacturer's replacement part number for each replaceable part. The history card should include the date of each periodic test, the test data, the type of repairs, the manhours, the cost of each repair, and the initials of the workman in charge of the job. This data can be transferred to a computer database for which there are many software packages available.

b. The data file is the only way to preserve the integrity of data accumulated over the life of the equipment. It indicates when maintenance costs are beginning to exceed the normally anticipated expense so plans can be initiated to purchase new or higher rated apparatus.

c. Since maintenance is a continuous activity, it is extremely important that historical records be kept and updated on all apparatus. The place for this type of information is in the maintenance department file, not in a hip pocket, notebook, or central engineering office where it cannot be reviewed regularly.

d. The record card should indicate the maintenance task performed, why it was necessary, and whether it was a routine breakdown or an emergency repair resulting from some extraneous cause.

Additional information should include how long it takes to perform the maintenance work on the equipment, and what particular maintenance tasks must be performed regularly. An immediate update of the record card should follow each maintenance period, and the report should be comprehensive enough to assist anyone in determining whether all required maintenance was performed. This also holds true for any type of maintenance periods, such as emergency repairs.

e. When adding circuits to existing equipment or making any changes in wiring different from the original drawings, it is essential that these changes be noted on the record cards. If wiring changes are not recorded when they have been made, they are sure to be forgotten and more time will be required to correct an otherwise routine maintenance task. More importantly, however, new circuits may be added and connected to points of greater power, causing them to remain energized when the circuit breaker is opened. Someone may be seriously injured because it is assumed that all connected circuits have been de-energized when power has been turned off at the source. Never add a circuit without first establishing its effect on the performance capabilities of the system or without immediately changing circuit drawings to show the source of power and the added load requirements. Such action can result in feeder circuits that are dangerously overloaded or a system imbalance. This can cause other connected loads to fluctuate or even be interrupted due to voltage drop when some high current equipment load is started or stopped in another area of the plant.

f. Each time a piece of equipment is serviced, a record should be made indicating the date, work performed, changes made, and probable cause of any problems other than routine servicing. A “fat file” may indicate a misapplication or misuse. It may also indicate that load conditions may have changed, requiring replacement with equipment of greater capacity and longer life.

9-4. Personnel qualifications

Maintenance personnel should be selected on the basis of qualifications for the job. Assignments should not be made on a hit-or-miss basis to those who happen to be idle at the moment. Equipment may be ruined by overzealous, inexperienced personnel. The maintenance department must not be a catchall for personnel who could not adjust elsewhere. The complexity of control systems in automatic and semi-automatic facilities requires well-educated and skilled personnel in the maintenance department. Very often, because of the newness and complexity of the maintenance requirements, special training may be required. A skilled maintenance force must be kept abreast of the latest techniques and developments in the field. This may be done by visiting plant maintenance shows, subscribing to appropriate periodicals, and attending specialized classes, panel discussions, and lectures.

a. A file of equipment manufacturers’ bulletins and instructions should be available to all maintenance personnel. Only modern testing equipment, good tools, and the latest methods should be used. Whenever possible, maintenance standards and testing procedures recommended by the Institute of Electrical and Electronics Engineers (IEEE), American National Standards Institute (ANSI), National Electrical Manufacturers Association (NEMA), InterNational Electrical Testing Association (NETA) and the National Fire Protection Association (NFPA) should be used. A good preventive maintenance program represents insurance against avoidable outages that can completely de-stabilize an IT facility.

b. Additional personnel who possess a greater degree of technical training and specialized skills should be added to the work force if necessary. However, when the plant inventory has only one or two pieces of specialized equipment, the maintenance department should call in a manufacturer’s field service representative when a problem develops, which is usually less costly in the long run.

c. Inexperienced personnel attempting to repair or service any type of apparatus can spend hours trying to locate trouble, and the repair could possibly cost more than the replacement of the equipment. In

the process the employee may disturb or alter adjustments which only a factory-trained service representative can restore, and his actions may affect the reliability of the equipment or even the entire system. There is also the possibility of further damaging the apparatus and incurring additional expense because of experimenting or attempting to keep equipment operating when it should be repaired. By using a manufacturer's representative, maintenance personnel can acquire a considerable amount of knowledge if they are present when the representative is working on the equipment. After a few service calls, the maintenance man may know enough about the equipment to repair and maintain it himself in the future.

d. Certain guidelines should be adhered to when selecting outside assistance to contribute to a maintenance program. It is of course possible to contract out all and every level of responsibility associated with maintenance and testing.

(1) There are certain advantages when utilizing contractor help.

(a) The testing and maintenance firm can be a corporately independent testing organization which can function as an unbiased testing authority, professionally independent of the manufacturers' suppliers, and installers of equipment or systems evaluated by the testing firm.

(b) The testing and maintenance firm is regularly engaged in the testing of electrical equipment devices, installations, and systems, and will, therefore, maintain a degree of expertise that may be difficult for in-house personnel to achieve and maintain on a cost effective basis.

(c) The testing and maintenance firm can be required to utilize only full-time technicians who are regularly employed by the firm. Electrically unskilled employees are not permitted to perform testing or assistance of any kind. Electricians and/or linemen may assist, but may not perform testing and/or inspection services.

(d) The testing and maintenance firm can supply all test equipment that may be required for any level maintenance.

(e) Test equipment furnished by an outside firm can be required to be inspected and calibrated within established industry standards.

(2) Disadvantages to using contractor help include the following.

(a) There can be many disadvantages associated with the maintenance program of any sensitive electrical system or for that matter, any system. There is, however, one disadvantage that may far outweigh any advantage.

(b) The testing and maintenance firm is not sensitive to, neither can it be motivated to be sensitive to, the critical intrinsic needs of the client.

9-5. Dedicated maintenance equipment

The maintenance equipment that is necessary to support, maintain, troubleshoot, and service the IT system is sensitive and sophisticated. A well organized maintenance department will own and maintain, or have ready access to all of the test equipment that shall be needed to support their mission.

a. The test equipment may be purchased and kept on site or it may be leased through an outside vendor. Test equipment may be furnished by a contracted maintenance agency. The manufacturers of the IT system equipment being maintained should be consulted when selecting test equipment.

b. Maintenance and test equipment that is used to maintain other equipment must also be maintained and serviced on a regular basis to insure its reliability and accuracy. Test equipment should be maintained by a qualified firm and a calibration program should be established which maintains all applicable test instrumentation within rated accuracy. The accuracy shall be traceable to the National Bureau of Standards in an unbroken chain.

(1) Instruments shall be calibrated in accordance with the following frequency schedule.

(*a*) Field instruments – 6 months maximum

(*b*) Laboratory instruments – 12 months

(*c*) Leased specialty equipment – 12 months

(*d*) Dated calibration labels shall be visible on all test equipment

(2) Records must be kept up-to-date which show date and results of all instruments calibrated or tested.

(3) An up-to-date instrument calibration instruction and procedure will be maintained for each test instrument.

c. Personnel assigned to the use of this equipment must be thoroughly trained in its efficient and safe use.

9-6. Renewal parts

Renewal parts have always been and probably always will be a very temperamental subject with accountants and budget planners. Renewal parts contribute nothing to a system until they are needed. The maintenance manager should place the stocking and continuous maintenance of renewal parts high on the priority list to maintaining a reliable IT system.

a. A carefully selected assortment of spare parts is essential to a good maintenance program and represents insurance against prolonged shutdowns. Even though repairs may not be made on the premises, keeping an adequate stock of spare parts will avoid delay in placing the machine back in service. Overstocking and understocking should be avoided. Overstocking results in excessive carrying costs as well as losses due to obsolescence when equipment is replaced. Understocking places the system in jeopardy if an outage occurs. Very often replacement parts for one machine may be used on many other units in the same area. In such instances it is unwise to stock spares for each unit alone, but to follow the manufacturer's recommendations concerning the minimum that is permissible for a group of equipment.

b. When making the decision to stock renewal parts, keep in mind the objectives of the maintenance program. If there is any uncertainty as to type and a variety of renewal parts to be stocked, the original equipment manufacturer should be consulted. The manufacturers should be provided with the critical nature of the system and the level of expertise of the personnel maintaining the system.

9-7. Continuous inspection program

The equipment within an electrical system is prone to failure for a myriad of reasons. These failures may occur for no apparent reason or the cause of failure may be poignantly apparent.

a. The failure of electrical equipment should be analyzed to assess reasons for its breakdown. Unless the cause is obvious, the equipment quality may be questioned. Reliability can be built into the equipment, but it requires upkeep to retain it. The tendency to ignore regular maintenance and testing generally prevails over regularly scheduled maintenance because regular maintenance may be considered unnecessary and too expensive. Therefore, the best designed and built equipment may break down through lack of attention. Every failure should be analyzed for its cause so that corrective measures can be implemented to prevent similar breakdowns.

b. A well-managed maintenance program will include an on-going and continuous inspection program to monitor equipment. The main objective of continuous inspection will be to avoid unscheduled outages and downtime. All equipment failures should also be reviewed and included in a continuous inspection program. The cause of equipment failure may be readily determined if analyzed soon after the failure occurs and other factors are available which may become lost if the analyzation process is delayed.

c. The importance of a continuous inspection program will be determined by the critical nature of the product of the IT system. The inspection program may be limited to taking daily load readings or it may include sophisticated computer monitoring of load, heat, and vibration sensors to list only a few.

9-8. Maintenance schedule

The purpose of the maintenance schedule is to establish the condition of the equipment and determine what work will be required before its next scheduled maintenance. Usually, manufacturers' service manuals specify recommended frequency of maintenance and/or inspection. These time intervals are based upon standard operating conditions and environments. If these standard conditions change for the equipment, then the frequency should be modified accordingly. However, once the frequency of scheduled maintenance is established, this schedule should be adhered to for at least several maintenance cycles.

a. The schedule should be adjusted if the equipment begins to experience unexpected failures. The frequency can be reduced by as much as 50 percent. On the other hand, if the equipment does not require maintenance for more than two inspections, the period of frequency for that equipment can be increased by as much as 50 percent. Adjustment should be continued until the optimum interval is found. Generally, the test frequency can vary from 6 months to 3 years.

b. An efficient maintenance department will schedule in advance jobs that cannot be performed while a plant is operating. Time must be allotted to do a good job, or the quality of the maintenance program and the equipment will eventually be affected. However, sufficient time must be allowed to perform proper maintenance. If more work is scheduled than can be completed during a shutdown, the equipment will be returned to service with certain maintenance tasks not completed. The net result is that the job card will indicate that servicing was performed, but in actuality certain operations will be missed and not reported. This means that these operations will not be performed until the apparatus is scheduled for maintenance at another time.

c. If components appear to be wearing out faster or repairs are required more frequently than in the past, it could be that the equipment is now required to carry additional loads for prolonged periods of time, or a single shift is now operating around the clock. This will accelerate maintenance requirements

and alter the maintenance schedule. For instance, a reduction in the life expectancy of expendable items such as contacts can only come about due to a greater number of operations or under additional load requirements.

d. The following guidelines provide a means by which an effective maintenance program can be scheduled.

- (1) Establish objectives for the maintenance department.
- (2) Plan the maintenance program in advance.
- (3) Train the employees in the necessary technical areas.
- (4) Initiate a data file on each piece of equipment, and keep it updated.
- (5) Perform all indicated maintenance according to the original schedule.
- (6) Call in a manufacturer's representative when necessary and provide necessary lead time so that the representative can be on hand for the maintenance.

9-9. Maintenance tests

Preventive maintenance and testing will allow the prediction of impending failure of a particular piece of equipment so that plans can be made to replace it without catastrophic results. The information on testing can be obtained from several different standards, such as the Insulated Cable Engineering Association (ICEA), NFPA, IEEE, ANSI, NEMA, NETA, Insurance Company Manuals (ICM), and others depending on the equipment to be tested.

a. Field tests are conducted to see whether newly installed equipment has been damaged, to indicate whether any corrective maintenance or replacement is necessary on existing equipment, to indicate if the equipment can continue to perform its design functions safely and adequately, to chart the gradual deterioration of the equipment over its service life, and to check new equipment before energization. The types of tests are acceptance tests, routine maintenance tests, and special maintenance tests that are conducted for specific purposes. Electrical system commissioning on new projects (equipment) is critical to ascertain that a system is installed properly and that it will operate as designed. The commissioning of a system encompasses individual testing of related components, the verification of the component interconnection against the drawings, and functional testing of the system as a whole.

(1) Acceptance tests are known as proof tests and are performed on new equipment, usually after installation and prior to energization. They are run to determine the following.

- (a) Whether the equipment is in compliance with the specification.
- (b) To establish a bench mark for future tests.
- (c) To determine that the equipment has been installed without damage.
- (d) To verify whether the equipment meets its design intent and limits.

(2) Maintenance tests are performed at regular intervals over the service life of the equipment. They are made concurrently with preventive maintenance. In the course of routine maintenance tests, it is

very helpful to record the information as it is found on the equipment and to also record the condition in which the equipment is left. Therefore, these tests can be further subdivided into the following.

(a) As-found tests are performed on equipment on receipt or after it has been taken out of service for maintenance, but before any maintenance work is done.

(b) As-left tests are performed after maintenance has been performed and just before re-energization. They can indicate the degree of improvement in the equipment and serve as a bench mark for comparison for future tests.

(3) Special maintenance tests are performed on equipment that is known to be defective or has been subjected to adverse conditions that may affect its operating characteristics. An example might be the fault interruption by a circuit breaker, which requires inspection, maintenance, and tests before it can be put back into service.

b. The final technical function in developing a maintenance and test program involves establishment of instructions, procedures, and methods to ensure that the equipment and system components operate without failure. The maintenance department should have fully developed procedures and instructions for thoroughly servicing all equipment and components. In addition, the maintenance department should develop shutdown procedures, safeguards, interlocking of equipment, alarms, and methods of recording data and reporting unusual conditions to the proper authority. The maintenance records should be further utilized to evaluate results and as an indicator of possible modifications or changes in the maintenance program. In other words, the recorded information should be used as historical data and for feedback to modify the maintenance program.

9-10. Safety

Safe performance of maintenance is of prime importance when planning a preventive maintenance program.

a. All electrical wiring should conform to the recommendations of the National Board of Fire Underwriters as presented in the National Electrical Code (NEC). Machinery and other equipment should be installed with a view toward easy accessibility for maintenance. Joints and valves for water, steam, waste, and other liquid-carrying lines should not be located over electrical apparatus unless such equipment is drip-proof or splash-proof as required. Only approved safety solvents should be used for cleaning insulation, bearings, and other parts.

b. Switches and circuit breakers should always be closed completely and with a swift firm action. This will enable the quick operation of a fuse or breaker if a fault exists. Partially closing the switch or tickling the contacts "to see if everything is alright" is dangerous. The high-resistance path of a partially closed switch will cause severe burning and arcing at the contacts.

c. Before attempting repair work on electrical equipment, it must be disconnected from the power supply. The incoming lines to the apparatus must be tested with a voltmeter or voltage tester of the correct range for positive proof that the circuit is dead. All capacitors, connected to the apparatus must be discharged.

d. The following rules and guidelines should be adhered to when performing any maintenance or testing.

(1) All circuits and equipment are to be considered as energized until proven de-energized by testing with voltage detectors, and grounding cables are connected. The voltage detectors selected should be for the class of voltage supplied to the circuits and equipment to be serviced.

(2) Personnel assigned to on-site electrical service work should be supplied with at least two electrical voltage detectors. The assigned personnel shall be qualified in the correct operation of each detector.

(3) Each electrical circuit and/or piece of equipment to be serviced should be tested by a qualified person and then tested by one other person who has been trained in the correct operation of the voltage detectors. This testing shall be performed in the assigned person's presence to insure that the electrical circuit and/or equipment is de-energized.

(4) The voltage detectors should be checked for proper operation immediately prior to and immediately after testing the electrical circuits and/or equipment to be serviced. These checks should be made on a known source of energized voltage, or with a specifically designed tester supplied by the detector vendor.

(5) While testing circuits and/or equipment, the person performing the tests shall wear lineman's safety rubber gloves designed for the class of voltage in the circuits and/or equipment to be serviced and other protective equipment for this work as specified in NFPA 70E.

e. Capacitors of any size and voltage class must be treated with special caution at all times. The ability of a capacitor to hold a potentially lethal charge for extremely long periods of time after it is de-energized makes it necessary to remove the capacitor from service in the following sequence.

(1) Isolate the capacitors by opening the breakers or isolation devices connecting them to the electrical system.

(2) Permit the capacitors to drain off the accumulated charge for five to ten minutes. (There is generally a built-in device which accomplishes this drain).

(3) Discharge and ground the capacitors. While performing these procedures, be very careful that sufficient distance is maintained from the capacitors with a "hot stick" in the event the drain-off device is not properly functioning.

(4) Vacuum circuit interrupters such as the types used in circuit breakers and load tap changers can generate lethal amounts of x-ray radiation.

f. Although the procedure for hipotting a vacuum circuit interrupter is similar to that used for any other electrical device, there are two areas that require the exercise of extra caution.

(1) During any hipotting operation, the main shield inside the interrupter can acquire an electrical charge that usually will be retained after the hipot voltage is removed. This shield is attached to the midband ring of the insulating envelope. A grounding stick should always be used to discharge the ring as well as the other metal parts of the assembly before touching the interrupter, connections, or breaker studs.

(2) High voltage applied across open gaps in a vacuum can produce hazardous x-radiation if the voltage across the contacts exceeds a certain level for a given contact gap. Therefore, do not make hipot tests on an open breaker at voltages higher than recommended by the manufacturer. During the hipot test,

the steel front panel and partial side panels should be assembled to the breaker. Personnel should stand in front of the breaker to take advantage of the shielding afforded by the panels. If this position is not practical, equivalent protection can be provided by limiting personnel exposure to testing four three-phase breakers per hour with the personnel not closer than 9 feet 10 inches to the interrupters. During equipment operation in the normal current carrying mode, there is no x-radiation because there are no open contacts.

(3) Refer to the equipment manufacturers' instruction manuals for proper testing methods and safety procedures.

g. Electrostatic coupling can be present in de-energized circuits at levels that may be fatal or cause involuntary reactions that may jeopardize personnel safety. When personnel are working on de-energized circuits that are adjacent to energized circuits, a flux linkage between circuits may occur if circuits are not properly grounded. Solid ground must be attached to the de-energized circuits at all times. De-energized equipment must always be grounded with an appropriate resistor grounding device before installing grounds and attempting to work on the equipment.

9-11. Electrical equipment fires

The standard procedure for fighting electrical fires is to open the circuit and then apply an approved extinguishing agent.

a. A carbon dioxide (CO₂) extinguisher offers the advantage of extinguishing the fire, cooling the apparatus, leaving no residue, and having no adverse affect on the insulation and metal parts, and it may be used on live circuits. Hence it is the preferred extinguishing agent for most electrical fires. However, when applied in confined spaces, such as in the engine room of a ship, the CO₂ should be purged with air before workmen are allowed to enter.

b. The dry-chemical extinguisher is satisfactory and may be used on live circuits. However, it leaves a residue and does not cool the apparatus so effectively as does the CO₂ extinguisher. A carbon tetrachloride extinguisher will put out the fire and cool the apparatus, but excessive use of this agent will be detrimental to the insulation and metal parts. Carbon tetrachloride is also very noxious and should be used only in well-ventilated places.

c. Water sprinklers and steam smothering apparatus may be used only after the circuit is de-energized. Such systems have been built into large machines and are very effective. The serious drawback to their extended usage is the time required to clean and dry the apparatus before it can be placed back in service.

d. Regardless of the type of extinguishing agent used, the apparatus should be thoroughly inspected and tested after the fire is out. The cause of the fire should be determined, and corrective action should be taken before the apparatus is put back in service. If no damage is apparent and an insulation-resistance test indicates normal, the apparatus may be started at reduced load and carefully observed as load is applied.

9-12. Equipment diagrams

To perform an effective maintenance program, it is necessary to have accurate data about the electrical power system. This may include one-line diagrams, short-circuit coordination studies, wiring and control diagrams, and other data that can be used as a reference point for future maintenance and testing. The purpose of these diagrams is to document and serve as an official record of equipment and circuit

installation. NEMA has established standards for diagram symbols, device designations, and electrical symbols. The types of diagrams and drawings in common use are the following.

- a.* A process or flow diagram is a conceptual diagram of the functional inter-relationship of subsystems in pictorial form.
- b.* A one-line (single-line) diagram shows, by means of single lines and graphic symbols, the flow of electrical power or the course of electrical circuits and how they are connected. In this diagram, physical relationships are usually disregarded.
- c.* Schematic (elementary) diagrams show all circuits and device elements of the equipment. This diagram emphasizes the device elements and their functions, and it is always drawn with all devices shown in de-energized mode.
- d.* A control sequence (truth-table) diagram is a description of the contact positions or connections that are made for each position of control action or device.
- e.* A wiring diagram (connection diagram) locates and identifies electrical devices, terminals, and interconnecting wires in an assembly. This diagram may show interconnecting wiring by lines or terminal designations.
- f.* Interconnection diagrams show only the external connections between controllers and associated equipment or between various housing units of an assembly of switchgear apparatus.
- g.* Circuit layout and routing diagrams show the physical layout of the facility and equipment and how the circuit to the various equipment is run.
- h.* Electrical power system data, diagrams, and drawings are needed during maintenance and testing of electrical equipment. This may involve information and data relating to protective devices and relays. Such data are usually found in a short-circuit coordination study and usually encompass all the short-circuit values available in the power system, relays, and trip device settings. Normally, this study is performed as part of the initial facility design, and then validated during the construction phase to assure that equipment and values specified have been met. When accepting the facility, this study data should be used as a bench mark, and any changes that may have been made during construction in the system should be incorporated to update the study for future references.
- i.* System diagrams will generally be needed for large systems. Such diagrams may consist of control and monitoring system, lighting system, ventilation system, heating and air-conditioning system, emergency system, and other systems. All the system diagrams may interface with one another, such as electrical diagrams, fire and security diagrams, emergency power, and hydraulic pneumatic or mechanical systems. Each system may depend upon the integrity of each associated system within a facility. It is, therefore, important to understand how these systems interface and how they can be coordinated into a maintenance and test program.

9-13. Test forms

A key factor in an efficient maintenance and testing program is the preparation and filing of all inspection and test records. This enables mathematical trends to be established, and to a great extent future performance and maintenance measures can be predicted. Forms permit the orderly recording of data and are a reminder to record all pertinent factors, for example, temperature and relative humidity. A variety of forms are available in the industry or they can be tailored to fit requirements as needed.

a. One method of filing is by apparatus with the original inspection or test, and all successive tests for that apparatus would be filed in chronological order with the latest test on top. The important fact is that records should be maintained (in whatever order or format that may be suitable) for comparison and evaluation.

b. Any efficient maintenance department should have forms available for their staff. A data file composed of consistent documentation is an integral part of any maintenance department. Test forms and procedures for specialty equipment are available from equipment manufacturers. It should be noted that forms can be generated to cover any set of unique circumstances that a qualified maintenance crew may encounter and that the attached forms are included only as samples and must not be regarded as the only specimen available.

APPENDIX A

REFERENCES

Required Publications

Government Publications

MIL-HDBK-419A

Grounding, Bonding, and Shielding for Electronic Equipment and Facilities (cited in 4-6c(11))

TM 5-694

Commissioning of Electrical Systems for Command, Control, Communications, Computer, Intelligence, Surveillance and Reconnaissance (C4ISR) Facilities (cited in paragraph 8-2g)

Non-Government Publications

Electric Power Research Institute (EPRI)

3412 Hillview Avenue, Palo Alto, CA 94304

Proceedings of EPRI's PQA '95

New York, NY, May 9-11, 1995

Hughes, M. B. and J. S. Chan, "Canadian National Power Quality Survey Results" (cited in paragraph 2-3i(3))

Sabin, D. D. and T. E. Grehe, "Preliminary Results of Monitoring from the EPRI Distribution Power Quality Project" (cited in paragraph 2-3i(3))

Key, T. S., D. S. Dorr, M. B. Hughes, and J. J. Stanislawski, "Matching Appliances to their Electrical Environments" (cited in paragraph 2-3i(3))

Information Technology Industry Council (ITI)

1250 Eye Street NW, Suite 200, Washington, D. C. 20005

(cited in paragraphs 2-3h., 2-3i(1), 3-3, 6-6m, 6-6n, and appendix B)

Institute of Electrical and Electronics Engineers (IEEE)

445 Hoes Lane, P. O. Box 1331 Piscataway, NJ 08855-1331

IEEE Std C37.13-1990

Standard for Low-Voltage ac Power Circuit Breakers Used in Enclosures (cited in paragraph 6-5h(4)(a))

IEEE Std C37.14-1992

Standard for Low-Voltage dc Power Circuit Breakers Used in Enclosures (cited in paragraph 6-5h(4)(a))

IEEE Std C37.20-1-1993

Standard for Metal-Enclosed Low-Voltage Power Circuit Breaker Switchgear (cited in paragraph 6-5h(4)(a))

ANSI/IEEE Guide C62.41-1991

IEEE Recommended Practice for Surge Voltages in Low Voltage AC Power Circuits (cited in appendix B 3.4)

IEEE Paper C74-199-6

Allen, G. W. and D. Segal, "Monitoring of Computer Installation for Power line Disturbances", (cited in paragraph 2-3i(2))

IEEE Transactions on Industry Applications

Key, T. S., "Diagnosing Power Quality-Related Computer Problems", Vol. 1A-15, No. 4, July/August 1979 (cited in paragraph 2-3i(3))

Martzloff, F. D. and T. S. Gruz, "Power Quality Site Surveys: Facts, Fiction, and Fallacies", Vol. 24, No. 6, Nov/Dec 1988 (cited in paragraph 2-3i(3))

Dorr, D. S., "Point of Utilization Power Quality Study Results", Vol. 1A-31, No. 4, July/August 1995 (cited in paragraph 2-3i(3))

IEEE International Telecommunications Energy Conference

Goldstein, M. and P. D. Speranza, "The Quality of U.S. Commercial AC Power", 1982, pp. 28-33, CH1818-4 (cited in paragraph 2-3i(3))

IEEE Std 241-1990

Recommended Practice for Electric Power Systems in Commercial Buildings (cited in paragraphs 6-2b, 6-6p)

IEEE Std 446-1995

Recommended Practice for Emergency and Standby Power Systems (IEEE Orange Book) (cited in paragraphs 6-2b and 6-6p)

IEEE Std 519-1992

Recommended Practices and Requirements for Harmonic Control in Electrical Power Systems (cited in paragraphs 5-1a, 5-1b)

National Electrical Manufacturers Association (NEMA)

2101 L Street, NW, Suite 300, Washington, DC 20037

NEMA ICS 10-1993

Industrial Control and Systems: AC Transfer Switch Equipment (cited in paragraph 6-6p)

Canadian Standards Association

178 Rexdale Blvd, Etobicoke ON M9W 1R3, Canada

C22.2 No. 107.1-95

General Use Power Supplies (cited in paragraph 6-6p)

The Electrical Generating Systems Association

1650 S. Dixie Highway, 5th Floor, Boca Raton, Florida 33432

EGSA 100S-1996

Performance Standard for Transfer Switches for Use with Engine Generator Sets (cited in paragraph 6-6p)

American National Standards Institute (ANSI)

1430 Broadway, New York, New York 10018

ANSI C37.16-1997

Low-Voltage Power Circuit Breakers and ac Power Circuit Protectors Preferred Ratings, Related Requirements, and Application Recommendations (cited in paragraph 6-5h(4)(a))

ANSI C37.17-1997

Trip Devices for ac and General Purpose dc Low Voltage Power Circuit Breakers (cited in paragraph 6-5h(4)(a))

National Fire Protection Association (NFPA)

One Batterymarch Park, P. O. Box 9101, Quincy, MA 02269-9101

NFPA 70-2005

National Electrical Code (cited in paragraphs 4-2, 4-2c, 4-2c(1), (2), 4-2d., 4-2e, 4-2f, 4-2f.(2), 4-2g, 4-2g(2), (3), 4-2h, 4-3a(2), 4-3b(2), 4-5c(2), 4-6a(2), 4-6b, 4-6b(2), 4-6b(6), 4-6b(10)(a), 4-6b(10)(b), 4-6b(10)(c), 5-6e, 6-2a, 6-6k(1 through 5), 6-6l, 8-4, 8-5a)

NFPA 780-1997

Standard for the Installation of Lightning Protection Systems (cited in paragraphs 7-3b(4), 7-3c(6), 7-3e, 7-3f(2), and 7-3g(2))

NFPA 70E

Standard for Electrical Safety in the Work Place (cited in paragraph 9-10d(5))

Underwriter's Laboratories, Inc. (UL)

333 Pfingsten Road, Northbrook, IL 60062-2096

96A

Master Label Code (cited in paragraph 7-3b(4))

1008

Transfer Switch Equipment (cited in paragraph 6-6q)

1449

Standard for Transient Voltage Surge Suppressors (cited in paragraphs 3-4i(1))

Lightning Protection Institute

3335 N. Arlington Hts. Rd., Suite E, Arlington Hts., IL 60004

Standard LPI-175
Installation Code (cited in paragraph 7-3b(4))

InterNational Electrical Testing Association (NETA)
P.O. Box 687, Morrison, CO 80645
www.netaworld.org

IETA 1 - 1997
Maintenance Testing Specifications for Electric Power Distribution Equipment and Systems

Related Publications

Government Publications

National Bureau of Standards; Washington, D.C.20234
Copies available from National Technical Information Service, U.S. Department of Commerce,
Springfield, VA 22161

FIPS PUB 94-1983
Federal Information Processing Standards Publication 94, Guideline on Electrical Power for
ADP Installations

Non-Government Publications

IEEE Std 142-1991
Recommended Practice for Grounding of Industrial and Commercial Power Systems (IEEE
Green Book)

IEEE Std 1100-1999
Recommended Practice for Powering and Grounding Electronic Equipment (IEEE Emerald
Book)

IEEE Std 1159-1995
Recommended Practice for Monitoring Electric Power Quality

NFPA 75-1999
Standard for the Protection of Electronic Computer/Data Processing Equipment

APPENDIX B

ITI (CBEMA) CURVE APPLICATION NOTE

The ITI (CBEMA) Curve, included within this Application Note, is published by Technical Committee 3 (TC3) of the Information Technology Industry Council (ITI, formerly known as the Computer & Business Equipment Manufacturer Association). It is available at <http://www.itic.org/technical/iticurv.pdf>.

1. SCOPE

The ITI (CBEMA) Curve (figure B-2) and this Application Note describe an ac input voltage envelope which typically can be tolerated (no interruption in function) by most information technology (IT) equipment. The Curve and this Application Note comprise a single document and are not to be considered separately from each other. They are not intended to serve as a design specification for products or ac distribution systems. The Curve and this Application Note describe both steady-state and transitory conditions.

2. APPLICABILITY

The Curve (figure B-2) and this Application Note are applicable to 120V nominal voltages obtained from 120V, 208Y/120V, and 120/240V 60 hertz systems. Other nominal voltages and frequencies are not specifically considered and it is the responsibility of the user to determine the applicability of these documents for such conditions.

3. DISCUSSION

This section provides a brief description of the individual conditions which are considered in the Curve. For all conditions, the term "voltage" implies an ideal condition of 120V root mean square (RMS), 60 hertz. Seven types of events are described in this composite envelope. Each event is briefly described in the following sections, with two similar line voltage sags being described under a single heading. Two regions outside the envelope are also noted. All conditions are assumed to be mutually exclusive at any point in time, and with the exception of steady-state tolerances, are assumed to commence from the nominal voltage. The timing between transients is assumed to be such that the IT equipment returns to equilibrium (electrical, mechanical, and thermal) prior to commencement of the next transient.

3.1 Steady-state tolerances. The steady-state range describes an RMS voltage which is either very slowly varying or is constant. The subject range is +/-10 percent from the nominal voltage. Any voltages in this range may be present for an indefinite period, and are a function of normal loadings and losses in the distribution system.

3.2 Line voltage swell. This region describes a voltage swell having a RMS amplitude of up to 120 percent of the RMS nominal voltage, with a duration of up to 0.5 seconds. This transient may occur when large loads are removed from the system or when voltage is supplied from sources other than the electric utility.

3.3 Low-frequency decaying ring wave. This region describes a decaying ring wave transient which typically results from the connection of power-factor-correction capacitors to an ac

distribution system. The frequency of this transient may range from 200 hertz to 5 kilohertz, depending upon the resonant frequency of the ac distribution system. The magnitude of the transient is expressed as a percentage of the peak 60 hertz nominal voltage (not the RMS value). The transient is assumed to be completely decayed by the end of the half-cycle in which it occurs. The transient is assumed to occur near the peak of the nominal voltage wave form. The amplitude of the transient varies from 140 percent for 200 hertz ring waves to 200 percent for 5 kilohertz ring waves, with a linear increase in amplitude with increasing frequency. Refer to figure B-1 for an example of a typical wave form.



Figure B-1. Typical low frequency decaying ring wave

3.4 High-frequency impulse and ring wave. This region describes the transients which typically occur as a result of lightning strikes. Wave shapes applicable to this transient and general test conditions are described in American National Standards Institute (ANSI)/Institute of Electrical and Electronics Engineers (IEEE) C62.41-1991. This region of the curve deals with both amplitude and duration (energy), rather than RMS amplitude. The intent is to provide an 80 joule minimum transient immunity.

3.5 Voltage sags. Two different RMS voltage sags are described. Generally, these transients result from application of heavy loads, as well as fault conditions, at various points in the ac distribution system. Sags to 80 percent of nominal (maximum deviation of 20 percent) are assumed to have a typical duration of up to 10 seconds, and sags to 70 percent of nominal (maximum deviation of 30 percent) are assumed to have a duration of up to 0.5 seconds.

3.6 Dropout. A voltage dropout includes both severe RMS voltage sags and complete interruptions of the applied voltage, followed by immediate re-application of the nominal voltage. The interruption may last up to 20 milliseconds. This transient typically results from the occurrence and subsequent clearing of faults in the ac distribution system.

3.7 No damage region. Events in this region include sags and dropouts which are more severe than those specified in the preceding paragraphs, and continuously applied voltages which are less than the lower limit of the steady-state tolerance range. The normal functional state of the IT equipment is not typically expected during these conditions, but no damage to the IT equipment should result.

3.8 Prohibited region. This region includes any surge or swell which exceeds the upper limit of the envelope. If IT equipment is subjected to such conditions, damage to the IT equipment may result.

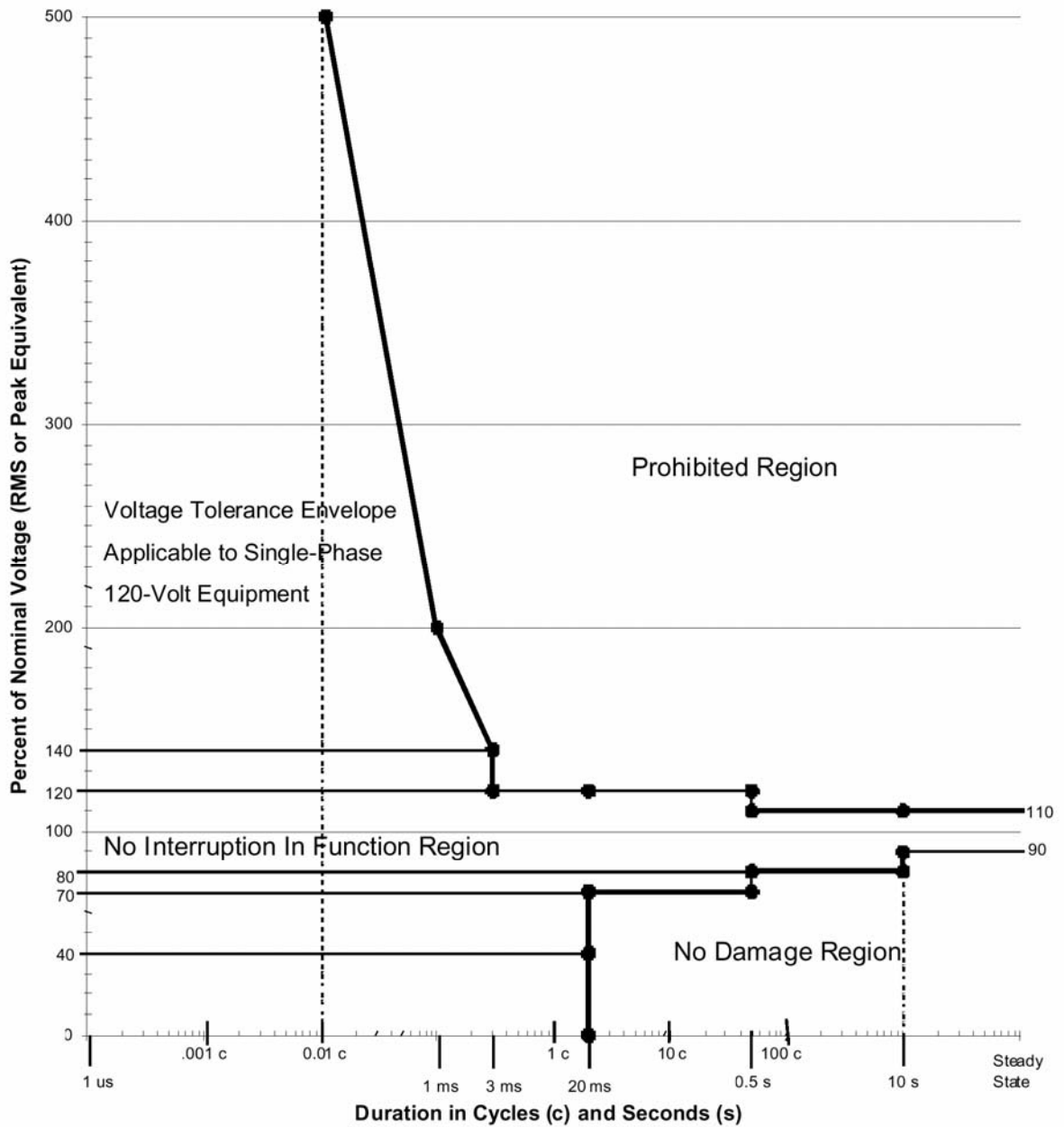

**Figure B-2. ITI (CBEMA) Curve
(Revised 2000)**

Published by:
 Information Technology Industry Council (ITI)
 1250 Eye Street NW Suite 200 Washington DC 20005
 202-737-8888
<http://www.itic.org>

May be reprinted with permission.

GLOSSARY

Section I Abbreviations

A
Ampere

ac
Alternating Current

ADP
Automated Data Processing

AFD
Adjustable Frequency Drives

AGM
Absorbent Glass Mat

Ah
Ampere-Hour

ANSI
American National Standards Institute

AWG
American Wire Gauge

CFC
Chlorofluorinated Hydrocarbons

CO₂
Carbon Dioxide

CPU
Central Processing Unit

dB
Decibels

dc
Direct Current

DIPS
Dual-in-line Packs

EM
Electromagnetic

EMI

Electromagnetic Interference

ESD

Electrostatic Discharge

FET

Field-Effect Transistors

GELL

Gelled Electrolyte Design

GHz

Gigahertz

HDF

Harmonic Distortion Factor

HVAC

Heating, Ventilating, and Air Conditioning

ICEA

Insulated Cable Engineering Association

ICM

Insurance Company Manuals

IEEE

Institute of Electrical and Electronics Engineers, Inc.

IGBT

Insulated Gate Bipolar Transistors

IT

Information Technology

ITI

Information Technology Industry Council

kHz

Kilohertz

KOH

Potassium Hydroxide

kVA

Kilovolt Amperes

kVAR

Kilovolt Amperes Reactive

kW

Kilowatts

LC

Inductive-Capacitive

LPI

Lightning Protection Institute

M-G

Motor-generator

MHz

megahertz

NEC

National Electrical Code

NEMA

National Electrical Manufacturers Association

NETA

International Electrical Testing Association

NFPA

National Fire Protection Association

NICAD

Nickel Cadmium

OSHA

Occupation Safety & Health Administration

pF

Picofarads

PVC

Polyvinyl Chloride

RF

Radio Frequency

RFI

Radio Frequency Interference

RMS

Root Mean Square

SCR

Silicon Controlled Rectifier

SMPS

Switching Mode Power Supplies

THD

Total Harmonic Distortion

TTL

Transistor-Transistor Logic

TVSS

Transient Voltage Surge Suppressors

UL

Underwriters' Laboratories

UPS

Uninterruptible Power Supplies

VA

Volt Ampere

VAR

Volt Amperes Reactive

VRLA

Valve Regulated Lead-Acid

Section II

Terms

ALARM

A condition which is annunciated but does not cause shutdown.

ALTERNATE POWER SOURCE

One or more generator sets, or battery systems where permitted, intended to provide power during the interruption of the normal electrical service; or the public utility electrical service intended to provide power during interruption of service normally provided by the generating facilities on the premises.

AMBIENT TEMPERATURE

The temperature of the environment immediately surrounding the systems into which heat is dissipated. For forced air-cooled units, the ambient temperature is measured at the air intake.

AMERICAN WIRE GAUGE (AWG)

A standard for sizing cross-sectional areas of wire and for measuring sheet-metal thickness

AMPERE (A)

Electron or current flow representing the flow of one coulomb per second past a given point in a circuit.

ANTIMONY

An element sometimes used to harden the plate material used in lead acid cells.

APPLIANCE

Electrical equipment, generally other than industrial, normally built in standardized sizes or types, which is installed or connected as a unit to perform one or more functions.

ARC

Sparking that results when undesired current flows between two points of differing potential. It may be due to leakage through a contaminated leakage path.

ARRESTER

A device placed across the conductors of a power transmission line or data line to suppress high-amplitude transients.

AUTOMATIC TRANSFER

A transfer between electrical power sources without operator/user involvement and is usually based upon the status or condition of the input/output ac power.

BATTERY

A group of cells connected to deliver more voltage and/or more current than a single cell.

BRANCH CIRCUIT

One division of a load circuit. Its current drain is limited by a fuse or circuit breaker.

BROWNOUT

A commercial line voltage reduction necessitated by inadequate generator capacity at a particular time. Nominal reductions are 3%, 5%, or 8%.

BYPASS SOURCE

An alternate source for the critical bus which can be connected to the load in the event of a UPS failure or for routine maintenance.

CALCIUM

An element sometimes used to harden the plate material used in lead acid cells.

CAPACITOR

Two plates or conductors separated by a dielectric material. Applying a voltage across the plates causes current to flow and stores a charge.

CELL

A unit containing a combination of metal plates and an electrolytic solution. When connected to an external circuit, a charged cell reacts chemically and delivers an electrical output.

CHARGE VOLTAGE

The voltage level maintained in a cell or battery in its maximum charge condition.

CIRCUIT BREAKER

A device, usually electro-mechanical, which detects excessive power demands in a circuit and self-interrupts when they occur.

CLAMP

To limit the voltage to a specified level by limiting the voltage source.

COAX

A cable consisting of two concentric conductors separated by a dielectric material. Usually flexible, but maintains constant conductor spacing under stress.

COMMON-MODE VOLTAGE

One common to both signal input (or power input) terminals of a circuit. An undesired common-mode voltage is usually developed between the zero signal reference ground and some other ground point.

COMMUTATION

A term used to mean "turning off a SCR." For this to be accomplished, the gate signal must be removed and the current through the SCR must be reduced to zero.

CONDUCTIVE

Adjective describing not only those materials, such as metals, which are commonly considered as electrically conductive, but also that class of materials which, when tested have a resistance not exceeding 1,000,000 ohms. Such materials are required where electrostatic interconnection is necessary.

CONNECTION

One which indicates the location and describes the types of connectors to be used at every junction in the distribution system.

CORE

The iron form or frame on which a choke or transformer is wound.

CRITICAL EQUIPMENT

That equipment essential to the safety of the occupants of the facility.

CRITICAL LOAD

Equipment that must have an uninterrupted power input to prevent damage to a facility or to itself, or to prevent damage or injury to operating personnel.

CROWBAR

The characteristic of a protective device (i.e., gas tubes, SCR, thyristor) causing a momentary short circuit between two protected points in a circuit when an over-voltage occurs.

DIRECT CURRENT (dc)

An electric current flowing in one direction.

DELTA

A method of connecting a three-phase source or load in a closed series loop with the output or input connections made to each of the three junctions.

DISK

A memory device used to store data for future computer use.

DUTY CYCLE

The ratio of operating time to non-operating time.

ELECTROLYTE

The acid or alkaline solution surrounding the plates of a battery cell.

EMERGENCY SYSTEM

A system of feeders and branch circuits used in meeting the requirements of Article 700 of NFPA 70, National Electrical Code, and intended to supply alternate power to a limited number of prescribed functions vital to the protection of life and safety, with automatic restoration of electrical power within ten seconds of power interruption.

ENGINE GENERATOR

Combination of an internal combustion engine and a generator.

EQUALIZE

A brief charge with an elevated voltage (about 2.33 volts/cell) to equalize the specific gravity of the cells in a battery string.

FARADAY SHIELD

A metallic housing, screen, or sheath that substantially reduces the effect of electric fields or for providing a means for reducing electrostatic coupling between conductors.

FAILURE

An incident which increases the hazard to personnel or patients or affects the safe functioning of electric appliance or devices. It includes failure of a component, loss of normal protection paths such as grounding, and short circuits or faults between energized conductors and the chassis.

FAULT CURRENT

A current in an accidental connection between an energized and a grounded or other conductive element resulting from a failure of insulation, spacing, or containment of conductors.

FEEDBACK

Energy coupled from the output of a circuit to its input.

FEEDER

All circuit conductors between the service equipment, or the generator switchboard of an isolated plant, and the final branch circuit over-current device.

FERRO-RESONANCE

Resonance resulting when the iron core of an inductor that's part of an LC circuit is saturated, increasing the inductive reactance to the value of the capacitive reactance.

FLASHOVER

Flashing due to high current flowing between two points of different potential. Usually due to the insulation breakdown caused by arcing.

FLOOR LOADING

A statement of the force, usually in lbs/ft², exerted on a floor when equipment is installed.

FLUCTUATION

A sag or swell in voltage amplitude, often caused by load switching or fault clearing.

FLYWHEEL

A large, heavy wheel used as a governor to maintain constant generator speed by inertial force.

FOLLOW CURRENT

The current from the connected power source that flows through an arrester (typically gas tube) during or following the passage of discharge current.

FREQUENCY DEVIATION

A swing away from nominal frequency.

GATE

A logic element but usually refers to the signal lead of an SCR. By applying a gate signal to this lead, the SCR can be commanded to the conducting state if it is forward biased.

GATE SIGNAL

The signal applied to the gate lead of a SCR by the GFM.

GROUND

A connection from a circuit or object to the earth.

GROUND FAULT

Any undesired current path from a point of differing potential to ground.

GROUNDING

A system of conductors which provides a low-impedance return path for leakage and fault currents. It coordinates with, but may be locally more extensive than, the grounding system described in Article 250, NFPA 70, National Electrical Code.

HARMONICS

A periodic waveform can be expressed as a sum of sinewaves which are integral multiples of the repetitive frequency of the waveform. The first harmonic is often referred to as the fundamental and is one times the frequency. The second harmonic is 2X, the third 3X, etc. Harmonics present in a waveform will cause its shape to deviate from a sinewave, so in UPS systems, it is desirable to have low harmonic distortion.

HARMONIC DISTORTION

The presence of harmonics that change an ac voltage waveform from sinusoidal to complex.

IMPEDANCE

Impedance is the ratio of the voltage drop across a circuit element to the current flowing through the same circuit element. The circuit element may consist of any combination of resistance, capacitance or inductance. The unit of impedance is the ohm.

INDUCTOR

A conductor, usually coiled, which tends to oppose any change in the flow of current through itself.

INRUSH CURRENT

The initial surge current demand before a load resistance or impedance increases to its normal operating value.

INVERTER

The subsystem of the UPS which converts dc power to ac power for the critical load.

ION

An electrically charged atom.

ISOLATION TRANSFORMER

Any transformer not having a dc current path connecting the primary and secondary windings.

JOULE

A unit of energy that is a function of voltage, current, and time. One joule is equal to one watt-second.

LINE CONDITIONER

A circuit or device designed to improve the quality of an ac line.

LOAD

The driven device that uses the power supplied by the source.

LOAD SWITCHING

Transferring the load from one source to another.

MAGNETIC FIELD

Flux, Φ . The pattern of magnetic force lines surrounding a magnet or energized electromagnet or inductor.

MIL-SPEC OR MIL-STD

Document issued by one of the military or government departments, stipulating specifications and outlining tests to determine that an item conforms to specifications.

MOTOR-GENERATOR

Combination of an ac motor and an ac generator. The motor is driven from the ac source and the generator becomes the new source for the load. Provides very good isolation from ac power line fluctuations and short-term anomalies.

NEUTRAL

The junction point of the legs in a wye circuit.

NEUTRALIZING WINDING

An extra winding that cancels the harmonics developed in the saturable secondary, resulting in a sinusoidal output from a ferroresonant transformer.

NOISE

Continuous or intermittent low energy disturbances superimposed on a useful waveform which may obscure its information content. Typically low voltage, low current, and repeatable frequency.

NON-PROGRAMMED JUMP

A skip of one or more of the ordered instructions in a computer program due to the presence of a spurious pulse or transient.

ORDERLY SHUTDOWN

Sequential shutdown of the units comprising a computer to prevent garbling or loss of data, or damage to the system.

OSCILLATION

Flywheel action in an LC circuit caused by the current generated by the alternate charge and discharge of the capacitor and the expansion and contraction of the magnetic field around the inductor.

PERIPHERAL

Any device used to process data for entry into or extraction from a computer.

PHASE COMPENSATION

Switching capacitors into or out of the power distribution network to compensate for load power factor variations.

PHASE CONTROL

A form of regulation which controls the output of a SCR circuit by varying the conduction time of the SCR.

PLANTE PLATE

A positive cell plate made from a cast lead antimony grid with lead buttons embedded in its surfaces. Named for its inventor.

POWER FACTOR

W/VA. The ratio of real power to apparent power. It will be “leading” or “lagging,” depending upon which way the load shifts the circuit current phase with respect to the voltage phase. Inductive loads cause the current to lag; capacitive loads cause the current to lead. Most loads are inductive.

POWER LINE MONITOR

A device to detect and indicate changes in power line frequency and/or voltage amplitude.

POWER OUTAGE

An interruption of commercial power.

POWER PROFILE

A graph of the power requirements for a composite load during the start-up period, from turn-on until steady-state operations commences.

PROTECTOR

A device that detects a fault and protects against it.

REACTANCE

The component of impedance contributed by inductance or capacitance. The unit of reaction is the ohm.

REFLECTION

The return wave generated when a traveling wave reaches the load, the source, or a junction point where there is a change in line impedance.

RELIABILITY

The likelihood of trouble-free performance from a component or an assembly. Principally, a function of MTBF and MTTR.

RESISTOR

A device or material that develops a voltage drop when current passes through it.

RESPONSE TIME

The time interval for a protective device to respond to a transient over-voltage condition and begin clamping.

ROTATING FIELD

The electrical field developed in a multi-phase generator. The varying currents through the pairs of stator windings cause the magnetic field to vary as if it were a single rotating field.

SATURABLE REACTOR

A transformer-like device. One winding has a core that saturates when a small amount of current is passed through it. This saturation causes a large change in the inductance of the main winding, thus controlling the current through it.

SENSOR

Any device used to detect electrical variations, temperature variations, etc., within a system.

SHUNT

A device used to convert a large dc current to a low dc voltage for metering purposes.

SHUNT TRIP

An electromagnetic trip used in circuit breakers to allow control circuits to open the breaker.

SOLENOID

A coil used to actuate a relay armature.

SPIKE

An unusually high and sharply defined transient.

STATIC SWITCH

A solid-state switch noted for its high speed. The static switch connects the bypass source to the critical bus in the event of a UPS failure. It is designed only for momentary use until the bypass breaker has time to close.

STRESS

External force or action applied to a component or assembly that tends to damage or destroy it.

SUBSTATION

A facility where power at lower levels is taken from the high voltage transmission line. Houses step-down transformers and switchgear required for local distribution.

SUPPRESSOR

A device that is used to arrest (keep down) excessive force, such as voltage transients. Will suppress unwanted voltage above a specified level.

SURGE

A sudden rise of current or voltage.

SURGE CURRENT

The current flowing in a circuit associated with a transient over-voltage condition.

SWITCHGEAR

Any switches, relays, or protective devices used to control power distribution.

SYNCHRONOUS MOTOR

An ac motor whose speed is exactly proportional to the power input frequency.

THREE-PHASE POWER

Three separate outputs from a single source. There is a phase difference of 120 degrees between any two of the three voltages.

TRANSDUCER

Any device that senses one form of energy and converts it to another, as sound, force, temperature, or humidity to electrical energy, or vice versa.

TRANSFER

Refers to the act of switching the critical load from the UPS to the bypass source or from the bypass source to the UPS.

TRANSFER SWITCH

One used to transfer the load from one source of power to a different source of power.

TRANSIENT

A high-amplitude, short-duration pulse superimposed on the normal voltage.

TRANSMISSION LINE

The conductors used to carry electrical energy from one location to another.

TRAVELING WAVE

One that moves along a transmission line in both directions from any point where a step voltage change occurs.

TRIP/TRIP CONDITION

If a major alarm condition is detected, the UPS will automatically remove itself from the sync bus and shut itself down. This is known as a "trip." Any condition that results in a trip is a trip condition.

UNINTERRUPTIBLE POWER SUPPLY (UPS)

A power source consisting of a rectifier, inverter, and batteries, continuously supplying power to a load from the inverter.

VOLT

Unit of measurement of electromotive force or potential difference. Symbol E, in electricity; symbol V in semiconductor circuits.

VOLTAGE

A derivative electrical quantity, E, measured in the unit volts and defined in terms of the independently obtained ampere, I, and the unit of resistance, ohm (R) by ohms law $E = IR$.

VOLTAGE CONTROL

A mode of regulation for the rectifier/charger or the inverter in which the output voltage is regulated to a constant value.

VOLTAGE DROP

Difference in potential between two points in a passive component or circuit.

VOLAGE REGULATOR

A circuit that develops a constant output voltage regardless of input voltage variation.

VOLTAGE REGULATION

1) The process of holding voltage constant between selected parameters, the extent of which is expressed as a percent. 2) The relative percent change of voltage during (cell/battery) discharge.

WYE

A three-phase source or load connection, with a single common junction and three-phase lines out or in.

The proponent agency of this publication is the Chief of Engineers, United States Army. Users are invited to send comments and suggested improvements on DA Form 2028 (Recommended Changes to Publications and Blank Forms) directly to HQUSACE, (ATTN: CEMP-OS-P), Washington, DC 20314-1000.

By Order of the Secretary of the Army:

Official:



JOYCE E. MORROW
*Administrative Assistant to the
Secretary of the Army*

PETER J. SCHOOMAKER
*General, United States Army
Chief of Staff*

Distribution:

To be distributed in accordance with Initial Distribution Number (IDN) 344736, requirements for non-equipment TM 5-689.

