

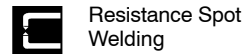

003 335A

July 2005

Processes



Description



Resistance Spot Welder

# HANDBOOK FOR Resistance Spot Welding

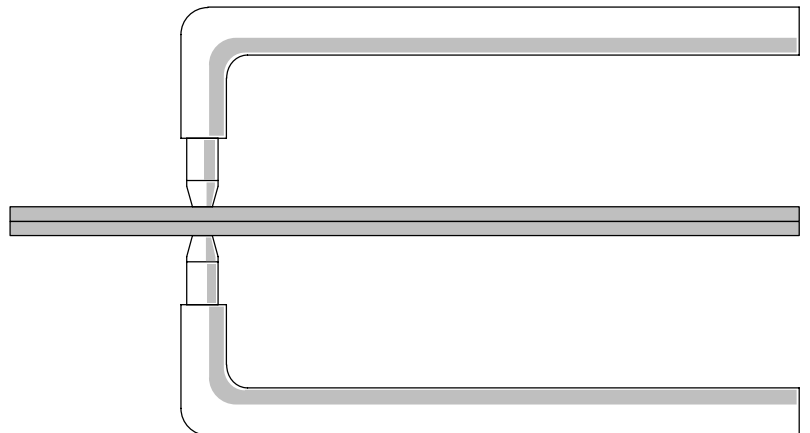

## WARNING

ARC WELDING can be hazardous.

This document contains general information about the topics discussed herein. This document is not an application manual and does not contain a complete statement of all factors pertaining to those topics.

This installation, operation, and maintenance of arc welding equipment and the employment of procedures described in this document should be conducted only by qualified persons in accordance with applicable codes, safe practices, and manufacturer's instructions.

Always be certain that work areas are clean and safe and that proper ventilation is used. Misuse of equipment, and failure to observe applicable codes and safe practices, can result in serious personal injury and property damage.



Visit our website at  
[www.MillerWelds.com](http://www.MillerWelds.com)



# TABLE OF CONTENTS

---

<b>SECTION 1 – SAFETY PRECAUTIONS - READ BEFORE USING</b> .....	<b>1</b>
1-1. Symbol Usage .....	1
1-2. Resistance Spot Welding Hazards .....	1
1-3. Additional Symbols For Installation, Operation, And Maintenance .....	2
1-4. California Proposition 65 Warnings .....	2
1-5. Principal Safety Standards .....	2
1-6. EMF Information .....	2
<b>SECTION 2 – CONSIGNES DE SÉCURITÉ – LIRE AVANT UTILISATION</b> .....	<b>3</b>
2-1. Signification des symboles .....	3
2-2. Dangers liés au soudage par points .....	3
2-3. Dangers supplémentaires en relation avec l'installation, le fonctionnement et la maintenance .....	4
2-4. Principales normes de sécurité .....	4
2-5. Information sur les champs électromagnétiques .....	4
<b>SECTION 3 – INTRODUCTION</b> .....	<b>5</b>
<b>SECTION 4 – FUNDAMENTALS OF RESISTANCE SPOT WELDING</b> .....	<b>6</b>
4-1. Principle .....	6
4-2. Heat Generation .....	6
4-3. The Time Factor .....	7
4-4. Pressure .....	7
4-5. Electrode Tips .....	7
4-6. Practical Uses Of Resistance Spot Welding .....	8
4-7. Electrode Tip Size .....	8
4-8. Pressure Or Welding Force .....	9
4-9. Miscellaneous Data .....	9
4-10. Heat Balance .....	9
4-11. Surface Conditions .....	10
4-12. Materials Data For Resistance Spot Welding .....	10
4-13. Mild Steel .....	10
4-14. Low Alloy And Medium Carbon Steels .....	11
4-15. Stainless Steels .....	11
4-16. Steels, Dip Coated Or Plated .....	11
4-17. Aluminum And Aluminum Alloys .....	11
4-18. Summary .....	12
4-19. Test Procedures .....	12
<b>SECTION 5 – MAINTENANCE AND TROUBLESHOOTING</b> .....	<b>13</b>
5-1. Maintenance .....	13
5-2. Dressing Tips .....	13
5-3. Troubleshooting .....	14



# SECTION 1 – SAFETY PRECAUTIONS - READ BEFORE USING

spotom\_nd\_8/03

## 1-1. Symbol Usage



Means Warning! Watch Out! There are possible hazards with this procedure! The possible hazards are shown in the adjoining symbols.

▲ Marks a special safety message.

☞ Means "Note"; not safety related.



This group of symbols means Warning! Watch Out! possible ELECTRIC SHOCK, MOVING PARTS, and HOT PARTS hazards. Consult symbols and related instructions below for necessary actions to avoid the hazards.

## 1-2. Resistance Spot Welding Hazards

▲ The symbols shown below are used throughout this manual to call attention to and identify possible hazards. When you see the symbol, watch out, and follow the related instructions to avoid the hazard. The safety information given below is only a summary of the more complete safety information found in the Safety Standards listed in Section 1-5. Read and follow all Safety Standards.

▲ Only qualified persons should install, operate, maintain, and repair this unit.

▲ During operation, keep everybody, especially children, away.

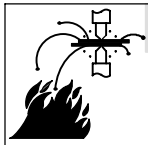

### SPOT WELDING can cause fire.

Sparks can fly off from the weld. The flying sparks, hot workpiece, and hot equipment can cause fires, burns, and explosions.

- Protect yourself and others from flying sparks and hot metal.
- Do not spot weld where flying sparks can strike flammable material.
- Remove all flammables within 35 ft (10.7 m) of the weld. If this is not possible, tightly cover them with approved covers.
- Be alert that welding sparks can easily go through small cracks and openings to adjacent areas.
- Watch for fire, and keep a fire extinguisher nearby.
- Do not spot weld on closed containers such as tanks or drums.
- Do not weld where the atmosphere may contain flammable dust, gas, or liquid vapors (such as gasoline).
- Remove any combustibles, such as a butane lighter or matches, from your person before doing any welding.
- After completion of work, inspect area to ensure it is free of sparks, glowing embers, and flames.
- Do not exceed the equipment rated capacity.
- Use only correct fuses or circuit breakers. Do not oversize or bypass them.



### ELECTRIC SHOCK can kill.

Touching live electrical parts can cause fatal shocks or severe burns. The input power circuit and machine internal circuits are also live when power is on. Incorrectly installed or improperly grounded equipment is a hazard.

- Do not touch live electrical parts.
- Wear dry, hole-free insulating gloves and body protection.
- Disconnect input power before installing or servicing this equipment. Lockout/tagout input power according to OSHA 29 CFR 1910.147 (see Safety Standards).

- Properly install and ground this equipment according to this manual and national, state, and local codes.
- Check and be sure that input power cord ground wire is properly connected to ground terminal in disconnect box or that cord plug is connected to a properly grounded receptacle outlet – always double-check the supply ground before applying power.
- When making input connections, attach the grounding conductor first – double-check connections.
- Keep cords dry, free of oil and grease, and protected from hot metal and sparks.
- Frequently inspect input power cord and ground conductor for damage or bare wiring – replace immediately if damaged – bare wiring can kill. Check ground conductor for continuity.
- Turn off all equipment when not in use.
- For water-cooled equipment, check and repair or replace any leaking hoses or fittings. Do not use any electrical equipment if you are wet or in a wet area.
- Use only well-maintained equipment. Repair or replace damaged parts at once.
- Wear a safety harness if working above floor level.
- Keep all panels, covers, and guards securely in place.

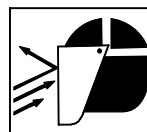

### FLYING SPARKS can cause injury.

Very often sparks fly off from the joint area.

- Wear approved face shield or safety goggles with side shields.
- Wear protective garments such as oil-free, flame-resistant leather gloves, heavy shirt, cuffless trousers, high shoes, and a cap. Synthetic material usually does not provide such protection.
- Protect others in nearby areas by using approved flame-resistant or noncombustible fire curtains or shields. Have all nearby persons wear safety glasses with side shields.



### HOT METAL can cause burns.

Wear gloves or allow cooling period before servicing tongs or tips.

- Always wear welding-type, insulated gloves when using this equipment.
- Do not touch workpiece, tips, or tongs with bare hands.
- Allow tongs and tips to cool before touching.

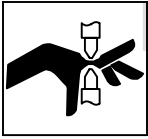

### MOVING PARTS can cause injury.

The tong tips, tongs, and linkages move during operation.

- Keep away from moving parts.
- Keep away from pinch points.
- Do not put hands between tips.
- Keep all guards and panels securely in place.
- OSHA and/or local codes may require additional guarding to suit the application.

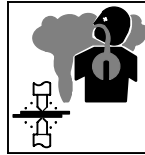

### FUMES can be hazardous.

Coatings, cleaners, paints, and platings can produce fumes when welded. Breathing these fumes can be hazardous to your health.

- Do not breathe the fumes.
- If inside, ventilate the area and/or use exhaust at the weld to remove fumes.
- In confined spaces, use an approved air-supplied respirator.
- Do not weld on coated metals, such as galvanized, lead, or cadmium plated steel, unless the coating is removed from the weld area, the area is well ventilated, or if necessary, while wearing an air-supplied respirator. The coatings and any metals containing these elements can give off toxic fumes if welded.
- Read the Material Safety Data Sheets (MSDSs) and the manufacturer's instructions for metals, coatings, and cleaners.

## 1-3. Additional Symbols For Installation, Operation, And Maintenance



### FIRE OR EXPLOSION hazard.

- Do not install or place unit on, over, or near combustible surfaces.
- Do not install or operate unit near flammables.
- Do not overload building wiring – be sure power supply system is properly sized, rated, and protected to handle this unit.



### FALLING EQUIPMENT can cause injury.

- Use equipment of adequate capacity to lift the unit.
- Have two people of adequate physical strength lift portable units.
- Secure unit during transport so it cannot tip or fall.

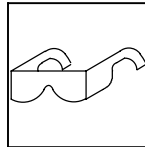

### FLYING METAL or DIRT can injure eyes.

- Wear approved safety glasses with side shields or wear face shield.

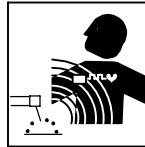

### MAGNETIC FIELDS can affect pacemakers.

- Pacemaker wearers keep away.
- Wearers should consult their doctor before going near resistance spot welding operations.

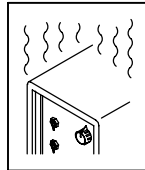

### OVERUSE can cause OVERHEATING.

- Allow cooling period; follow rated duty cycle.
- Reduce duty cycle before starting to weld again.

## 1-4. California Proposition 65 Warnings

- ▲ **Welding or cutting equipment produces fumes or gases which contain chemicals known to the State of California to cause birth defects and, in some cases, cancer. (California Health & Safety Code Section 25249.5 et seq.)**
- ▲ **Battery posts, terminals and related accessories contain lead and lead compounds, chemicals known to the State of California to cause cancer and birth defects or other reproductive harm. Wash hands after handling.**

### For Gasoline Engines:

- ▲ **Engine exhaust contains chemicals known to the State of California to cause cancer, birth defects, or other reproductive harm.**

### For Diesel Engines:

- ▲ **Diesel engine exhaust and some of its constituents are known to the State of California to cause cancer, birth defects, and other reproductive harm.**

## 1-5. Principal Safety Standards

*Safety in Welding and Cutting*, ANSI Standard Z49.1, from American Welding Society, 550 N.W. LeJeune Rd, Miami FL 33126

*Safety and Health Standards*, OSHA 29 CFR 1910, from Superintendent of Documents, U.S. Government Printing Office, Washington, D.C. 20402.

*National Electrical Code*, NFPA Standard 70, from National Fire Protection Association, Batterymarch Park, Quincy, MA 02269.

*Code for Safety in Welding and Cutting*, CSA Standard W117.2, from Canadian Standards Association, Standards Sales, 178 Rexdale Boulevard, Rexdale, Ontario, Canada M9W 1R3.

*Safe Practices For Occupation And Educational Eye And Face Protection*, ANSI Standard Z87.1, from American National Standards Institute, 1430 Broadway, New York, NY 10018.

*Cutting And Welding Processes*, NFPA Standard 51B, from National Fire Protection Association, Batterymarch Park, Quincy, MA 02269.

## 1-6. EMF Information

Considerations About Welding And The Effects Of Low Frequency Electric And Magnetic Fields

Welding current will cause electromagnetic fields. There has been and still is some concern about such fields. However, after examining more than 500 studies spanning 17 years of research, a special blue ribbon

committee of the National Research Council concluded that: "The body of evidence, in the committee's judgment, has not demonstrated that exposure to power-frequency electric and magnetic fields is a human-health hazard." However, studies are still going forth and evidence continues to be examined.

# SECTION 2 – CONSIGNES DE SÉCURITÉ – LIRE AVANT UTILISATION

spot\_fre 8/03

## 2-1. Signification des symboles



Signifie Mise en garde ! Soyez vigilant ! Cette procédure présente des risques de danger ! Ceux-ci sont identifiés par des symboles adjacents aux directives.

▲ Identifie un message de sécurité particulier.

☞ Signifie NOTA ; n'est pas relatif à la sécurité.



Ce groupe de symboles signifie Mise en garde ! Soyez vigilant ! Il y a des risques de danger reliés aux CHOCS ÉLECTRIQUES, aux PIÈCES EN MOUVEMENT et aux PIÈCES CHAUDES. Reportez-vous aux symboles et aux directives ci-dessous afin de connaître les mesures à prendre pour éviter tout danger.

## 2-2. Dangers liés au soudage par points

▲ Les symboles représentés ci-dessous sont utilisés dans ce manuel pour attirer l'attention et identifier les dangers possibles. Lorsque vous rencontrez un symbole, prenez garde et suivez les instructions afférentes pour éviter tout risque. Les instructions en matière de sécurité indiquées ci-dessous ne constituent qu'un sommaire des instructions de sécurité plus complètes fournies dans les normes de sécurité énumérées dans la Section 2-4. Lisez et observez toutes les normes de sécurité.

▲ Seul un personnel qualifié est autorisé à installer, faire fonctionner, entretenir et réparer cet appareil.

▲ Pendant le fonctionnement, maintenez à distance toutes les personnes, notamment les enfants de l'appareil.

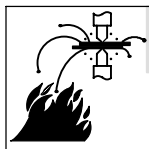

### LE SOUDAGE PAR POINTS peut provoquer un incendie.

Des étincelles peuvent être projetées de la soudure. La projection d'étincelles ainsi que les pièces et équipements chauds peuvent provoquer des incendies, des brûlures et des incendies.

- Protégez-vous, ainsi que toute autre personne travaillant sur les lieux, contre les étincelles et le métal chaud.
- Ne soudez pas par points dans un endroit où des étincelles peuvent tomber sur des substances inflammables.
- Déplacez toute matière inflammable se trouvant dans un périmètre de 10 m de la pièce à souder. Si cela est impossible, couvrez-les de housses approuvées et bien ajustées.
- Des étincelles du soudage peuvent facilement passer dans d'autres zones en traversant de petites fissures et des ouvertures.
- Afin d'éliminer tout risque de feu, soyez vigilant et gardez toujours un extincteur à portée de main.
- Ne soudez pas par points sur un récipient fermé tel un réservoir ou un bidon.
- Ne soudez pas si l'air ambiant est chargé de particules, gaz, ou vapeurs inflammables (vapeur d'essence, par exemple).
- Avant de souder, retirez toute substance combustible de vos poches telles qu'un briquet au butane ou des allumettes.
- Une fois le travail achevé, assurez-vous qu'il ne reste aucune trace d'étincelles incandescentes ni de flammes.
- Ne dépassez pas la puissance permise de l'équipement.
- Utilisez exclusivement des fusibles ou coupe-circuits appropriés. Ne pas augmenter leur puissance; ne pas les ponter.



### UNE DÉCHARGE ÉLECTRIQUE peut entraîner la mort.

Le fait de toucher à une pièce électrique sous tension peut donner une décharge fatale ou entraîner des brûlures graves. L'alimentation d'entrée et les circuits internes de l'appareil sont également actifs lorsque le poste est sous tension. Un poste

incorrectement installé ou inadéquatement mis à la terre constitue un danger.

- Ne touchez pas aux pièces électriques sous tension.
- Portez des gants isolants et des vêtements de protection secs et sans trous.

- Coupez l'alimentation d'entrée avant d'installer l'appareil ou d'effectuer l'entretien. Verrouillez ou étiquetez la sortie d'alimentation selon la norme OSHA 29 CFR 1910.147 (reportez-vous aux Principales normes de sécurité).
- Installez le poste correctement et mettez-le à la terre conformément aux consignes de ce manuel et aux normes nationales, provinciales et locales.
- Assurez-vous que le fil de terre du cordon d'alimentation est correctement relié à la borne de terre du sectionneur ou que la fiche du cordon est branchée à une prise correctement mise à la terre – vous devez toujours vérifier la mise à la terre avant toute mise sous tension.
- Avant d'effectuer les connexions d'alimentation, vous devez connecter en premier lieu le fil de terre - contrôlez les connexions.
- Les câbles doivent être exempts d'humidité, d'huile et de graisse; protégez-les contre les étincelles et les pièces métalliques chaudes.
- Assurez-vous régulièrement que les câbles d'alimentation et de masse ne sont pas endommagés ou dénudés par endroit. Remplacez-les immédiatement si c'est le cas : un câble dénudé peut provoquer la mort. Contrôlez la continuité de la mise à la terre.
- L'équipement doit être hors tension lorsqu'il n'est pas utilisé.
- Dans le cas d'équipements refroidis par eau, contrôlez les conduites et raccords; remplacez-les s'ils présentent des fuites. N'utilisez pas d'équipement électrique si vous êtes mouillé ou dans une zone humide.
- Utilisez uniquement un équipement en bonne condition. Réparez ou remplacez immédiatement toute pièce endommagée.
- Portez un harnais de sécurité si vous devez travailler au-dessus du sol.
- Maintenez en place les panneaux, couvercles et protections de sécurité.

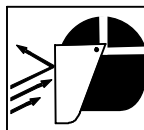

### LES ÉTINCELLES VOLANTES risquent de provoquer des blessures.

Des étincelles peuvent jaillir de la soudure.

- Portez une visière ou des lunettes de sécurité avec des écrans latéraux approuvés.
- Portez un équipement de protection: gants en cuir résistant au feu, chemise épaisse, pantalon sans revers, chaussures de sécurité et casquette. Les matériaux synthétiques ne garantissent pas une bonne protection.
- Protégez les autres occupants du local à l'aide d'un rideau ou d'un écran ignifuge approprié. Assurez-vous que ces personnes portent des lunettes de sécurité avec protections latérales.



### LE MÉTAL CHAUD peut provoquer des brûlures.

Portez des gants ou laissez refroidir les électrodes avant de procéder à l'entretien.

- Portez toujours de gants de soudeur lorsque vous utilisez cet équipement.
- Ne touchez pas les pièces ni les électrodes avec les mains.
- Laissez les électrodes refroidir avant de les toucher.

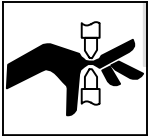

### DES ORGANES MOBILES peuvent provoquer des blessures.

Pendant le soudage, les bras et électrodes se déplacent.

- Ne pas s'approcher des organes mobiles.
- Ne pas s'approcher des points de coincement.
- Ne placez pas les mains entre les électrodes.
- Maintenez en place les panneaux et protections de sécurité.
- Les applications peuvent nécessiter des protections supplémentaires d'après les codes de sécurité locales.

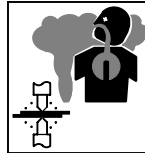

### LES FUMÉES peuvent être dangereuses.

Lors du soudage, les revêtements, produits de nettoyage, peintures et placages peuvent dégager des fumées. Leur inhalation peut être dangereuse.

- Ne respirez pas les fumées.
- Si vous soudez à l'intérieur, ventilez le local et/ou ayez recours à une ventilation aspirante installée près de la soudure pour évacuer les fumées.
- Dans des lieux exigus, utilisez un appareil respiratoire approprié.
- Ne pas souder des métaux munis d'un revêtement, tels que l'acier galvanisé, plaqué en plomb ou au cadmium à moins que le revêtement n'ait été enlevé dans la zone de soudure, que l'endroit soit bien ventilé, et si nécessaire, en portant un respirateur à alimentation d'air. Les revêtements et tous les métaux renfermant ces éléments peuvent dégager des fumées toxiques en cas de soudage.
- Veuillez lire les consignes de sécurité et les instructions du fabricant pour les métaux, revêtements et produits de nettoyage.

## 2-3. Dangers supplémentaires en relation avec l'installation, le fonctionnement et la maintenance



### Risque D'INCENDIE OU D'EXPLOSION.

- Ne pas placer l'appareil sur, au-dessus ou à proximité de surfaces inflammables.
- Ne pas installer ni faire fonctionner l'appareil à proximité de substances inflammables.
- Ne pas surcharger l'installation électrique – s'assurer que l'alimentation est correctement dimensionnée et protégée avant de mettre l'appareil en service.

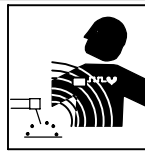

### LES CHAMPS MAGNÉTIQUES peuvent affecter les stimulateurs cardiaques.

- Porteurs de stimulateur cardiaque, restez à distance.
- Les porteurs d'un stimulateur cardiaque doivent d'abord consulter leur médecin avant de s'approcher des opérations de soudage par points.



### LA CHUTE DE L'ÉQUIPEMENT peut blesser.

- Utiliser un engin d'une capacité appropriée pour soulever l'appareil.
- Faites déplacer les équipements portables par deux personnes dotées d'une force suffisante.
- Durant le transport, immobilisez l'appareil pour éviter qu'il ne bascule.

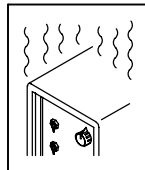

### L'EMPLOI EXCESSIF peut SURCHAUFFER L'ÉQUIPEMENT.

- Prévoir une période de refroidissement; respecter le cycle opératoire nominal.
- Réduire le facteur de marche avant de poursuivre le soudage.

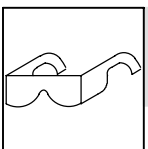

### DES PIÈCES DE MÉTAL ou DES SALETÉS peuvent provoquer des blessures aux yeux.

- Porter des lunettes de sécurité à coques latérales ou un écran facial.

## 2-4. Principales normes de sécurité

*Safety in Welding and Cutting*, norme ANSI Z49.1, de l'American Welding Society, 550 N.W. Lejeune Rd, Miami FL 33126

*Safety and Health Standards*, OSHA 29 CFR 1910, du Superintendent of Documents, U.S. Government Printing Office, Washington, D.C. 20402.

*National Electrical Code*, NFPA Standard 70, de la National Fire Protection Association, Batterymarch Park, Quincy, MA 02269.

*Règles de sécurité en soudage, coupage et procédés connexes*, norme CSA W117.2, de l'Association canadienne de normalisation, vente de normes, 178 Rexdale Boulevard, Rexdale (Ontario) Canada M9W 1R3.

*Safe Practices For Occupation And Educational Eye And Face Protection*, norme ANSI Z87.1, de l'American National Standards Institute, 1430 Broadway, New York, NY 10018.

*Cutting and Welding Processes*, norme NFPA 51B, de la National Fire Protection Association, Batterymarch Park, Quincy, MA 02269.

## 2-5. Information sur les champs électromagnétiques

Données sur le soudage électrique et sur les effets, pour l'organisme, des champs magnétiques basse fréquence

L'extrait suivant est tiré des conclusions générales du document intitulé *Biological Effects of Power Frequency Electric & Magnetic Fields – Background Paper*, OTA-BP-E-53 (Washington DC : U.S. Government Printing Office, mai 1989), publié par le Office of Technology Assessment du Congrès américain : «... il existe maintenant d'abondantes données scientifiques compilées à la suite d'expériences sur la cellule ou d'études sur des animaux et des humains, qui montrent clairement

que les champs électromagnétiques basse fréquence peuvent avoir des effets sur l'organisme et même y produire des transformations. Même s'il s'agit de travaux de très grande qualité, les résultats sont complexes. Cette démarche scientifique ne nous permet pas d'établir un tableau d'ensemble cohérent. Pire encore, elle ne nous permet pas de tirer des conclusions finales concernant les risques éventuels, ni d'offrir des conseils sur les mesures à prendre pour réduire sinon éliminer les risques éventuels». (Traduction libre)

## SECTION 3 – INTRODUCTION

Resistance welding is one of the oldest of the electric welding processes in use by industry today. The weld is made by a combination of heat, pressure, and time. As the name resistance welding implies, it is the resistance of the material to be welded to current flow that causes a localized heating in the part. The pressure exerted by the tongs and electrode tips, through which the current flows, holds the parts to be welded in intimate contact before, during, and after the welding current time cycle. The required amount of time current flows in the joint is determined by material thickness and type, the amount of current flowing, and the cross-sectional area of the welding tip contact surfaces.

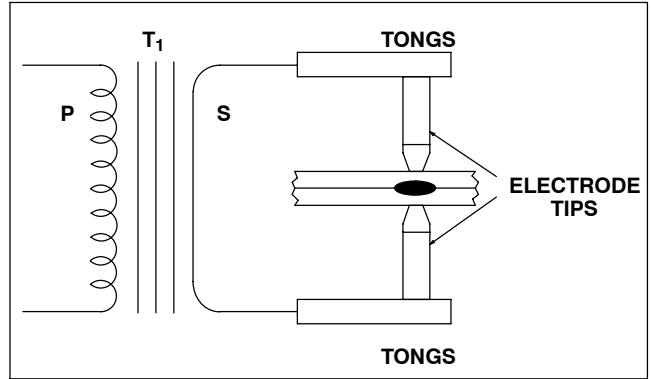

**Figure 3-1. Resistance Spot Welding Machine With Work**

In Figure 3-1, a complete secondary resistance spot welding circuit is illustrated. For clarity, the various parts of the resistance spot welding machine are identified.

# SECTION 4 – FUNDAMENTALS OF RESISTANCE SPOT WELDING

## 4-1. Principle

Resistance welding is accomplished when current is caused to flow through electrode tips and the separate pieces of metal to be joined. The resistance of the base metal to electrical current flow causes localized heating in the joint, and the weld is made.

The resistance spot weld is unique because the actual weld nugget is formed internally with relation to the surface of the base metal. Figure 4-1 shows a resistance spot weld nugget compared to a gas tungsten-arc (TIG) spot weld.

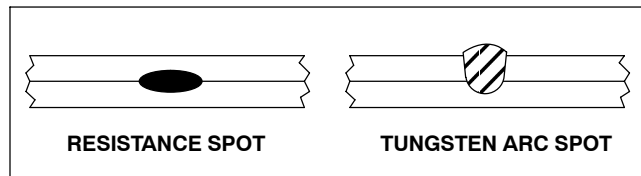

Figure 4-1. Resistance And TIG Spot Weld Comparison

The gas tungsten-arc spot is made from one side only. The resistance spot weld is normally made with electrodes on each side of the workpiece. Resistance spot welds may be made with the workpiece in any position.

The resistance spot weld nugget is formed when the interface of the weld joint is heated due to the resistance of the joint surfaces to electrical current flow. In all cases, of course, the current must flow or the weld cannot be made. The pressure of the electrode tips on the workpiece holds the part in close and intimate contact during the making of the weld. Remember, however, that resistance spot welding machines are NOT designed as force clamps to pull the workpieces together for welding.

## 4-2. Heat Generation

A modification of Ohm's Law may be made when watts and heat are considered synonymous. When current is passed through a conductor the electrical resistance of the conductor to current flow will cause heat to be generated. The basic formula for heat generation may be stated:

$$H = I^2R \quad \text{where } H = \text{Heat}$$

$$I^2 = \text{Welding Current Squared}$$

$$R = \text{Resistance}$$

The secondary portion of a resistance spot welding circuit, including the parts to be welded, is actually a series of resistances. The total additive value of this electrical resistance affects the current output of the resistance spot welding machine and the heat generation of the circuit.

The key fact is, although current value is the same in all parts of the electrical circuit, the resistance values may vary considerably at different points in the circuit. The heat generated is directly proportional to the resistance at any point in the circuit.

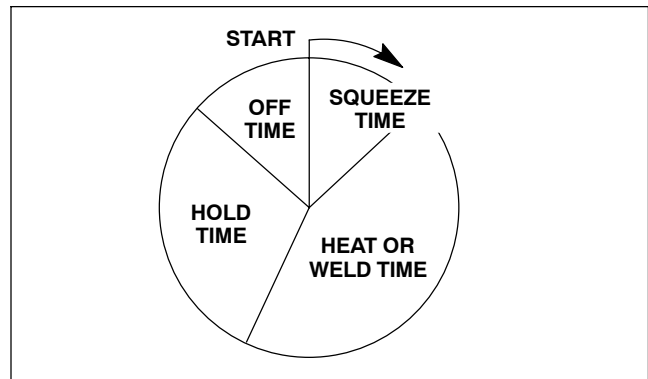

Figure 4-2. Spot Welding Time Cycle

**SQUEEZE TIME** – Time between pressure application and weld.

**HEAT OR WELD TIME** – Weld time is cycles.

**HOLD TIME** – Time that pressure is maintained after weld is made.

**OFF TIME** – Electrodes separated to permit moving of material for next spot.

The resistance spot welding machines are constructed so minimum resistance will be apparent in the transformer, flexible cables, tongs, and electrode tips. The resistance spot welding machines are designed to bring the welding current to the weldment in the most efficient manner. It is at the weldment that the greatest relative resistance is required. The term "relative" means with relation to the rest of the actual welding circuit.

There are six major points of resistance in the work area. They are as follows:

1. The contact point between the electrode and top workpiece.
2. The top workpiece.
3. The interface of the top and bottom workpieces.
4. The bottom workpiece.
5. The contact point between the bottom workpiece and the electrode.
6. Resistance of electrode tips.

The resistances are in series, and each point of resistance will retard current flow. The amount of resistance at point 3, the interface of the workpieces, will depend on the heat transfer capabilities of the material, its electrical resistance, and the combined thickness of the materials at the weld joint. It is at this part of the circuit that the nugget of the weld is formed.

### 4-3. The Time Factor

Resistance spot welding depends on the resistance of the base metal and the amount of current flowing to produce the heat necessary to make the spot weld. Another important factor is time. In most cases several thousands of amperes are used in making the spot weld. Such amperage values, flowing through a relatively high resistance, will create a lot of heat in a short time. To make good resistance spot welds, it is necessary to have close control of the time the current is flowing. Actually, time is the only controllable variable in most single impulse resistance spot welding applications. Current is very often economically impractical to control. It is also unpredictable in many cases.

Most resistance spot welds are made in very short time periods. Since alternating current is normally used for the welding process, procedures may be based on a 60 cycle time (sixty cycles = 1 second). Figure 4-2 shows the resistance spot welding time cycle.

Previously, the formula for heat generation was used. With the addition of the time element, the formula is completed as follows:

$$H = I^2RTK \quad \text{where } H = \text{Heat}$$

$$I^2 = \text{Current Squared}$$

$$R = \text{Resistance}$$

$$T = \text{Time}$$

$$K = \text{Heat Losses}$$

Control of time is important. If the time element is too long, the base metal in the joint may exceed the melting (and possibly the boiling) point of the material. This could cause faulty welds due to gas porosity. There is also the possibility of expulsion of molten metal from the weld joint, which could decrease the cross section of the joint weakening the weld. Shorter weld times also decrease the possibility of excessive heat transfer in the base metal. Distortion of the welded parts is minimized, and the heat affected zone around the weld nugget is substantially smaller.

### 4-4. Pressure

The effect of pressure on the resistance spot weld should be carefully considered. The primary purpose of pressure is to hold the parts to be welded in intimate contact at the joint interface. This action assures consistent electrical resistance and conductivity at the point of weld. The tongs and electrode tips should NOT be used to pull the workpieces together. The resistance

spot welding machine is not designed as an electrical "C" clamp! The parts to be welded should be in intimate contact BEFORE pressure is applied.

Investigations have shown that high pressures exerted on the weld joint decrease the resistance at the point of contact between the electrode tip and the workpiece surface. The greater the pressure the lower the resistance factor.

Proper pressures, with intimate contact of the electrode tip and the base metal, will tend to conduct heat away from the weld. Higher currents are necessary with greater pressures and, conversely, lower pressures require less amperage from the resistance spot welding machine. This fact should be carefully noted particularly when using a heat control with the various resistance spot welding machines.

### 4-5. Electrode Tips

Copper is the base metal normally used for resistance spot welding tongs and tips. The purpose of the electrode tips is to conduct the welding current to the workpiece, to be the focal point of the pressure applied to the weld joint, to conduct heat from the work surface, and to maintain their integrity of shape and characteristics of thermal and electrical conductivity under working conditions.

Electrode tips are made of copper alloys and other materials. The Resistance Welders Manufacturing Association (RWMA) has classified electrode tips into two groups:

Group A – Copper based alloys

Group B – Refractory metal tips

The groups are further classified by number. Group A, Class I, II, III, IV, and V are made of copper alloys. Group B, Class 10, 11, 12, 13, and 14 are the refractory alloys.

Group A, Class I electrode tips are the closest in composition to pure copper. As the Class Number goes higher, the hardness and annealing temperature values increase, while the thermal and electrical conductivity decreases.

Group B compositions are sintered mixtures of copper and tungsten, etc., designed for wear resistance and compressive strength at high temperatures. Group B, Class 10 alloys have about 40 percent the conductivity of copper with conductivity decreasing as the number value increases. Group B electrode tips are not normally used for applications in which resistance spot welding machines would be employed.

## 4-6. Practical Uses Of Resistance Spot Welding

▲ **SPOT WELDING** can be hazardous. Read and follow Safety Section at front of this book as well as the Owner's Manual and all labels on the equipment.

Resistance spot welding techniques do not require extensive or elaborate safety precautions. There are some common sense actions that can, however, prevent injury to the operator.

Anytime work is being done in a shop, it is a wise rule to wear safety glasses. Resistance spot welding is no exception to the rule! Very often metal or oxides are expelled from the joint area. Protection of the face and especially of the eyes is necessary to prevent serious injury.

Another area of concern is ventilation. This can be a serious problem when resistance spot welding galvanized metals (zinc coated) or metals with other coatings such as lead. The fumes from the welding operation have a certain toxicity which will cause illness to the operator. Proper ventilation can reduce the fume concentration in the welding area.

As explained in the preceding discussion on the fundamentals of resistance spot welding, there is a definite relationship between time, current, and pressure. Current and pressure help create the heat in the weld nugget.

If the weld current is too low for the application, current density is too weak to make the weld. This condition will also overheat the electrode tips which can cause them to anneal, mushroom, and possibly be contaminated. Even though time is increased, the amount of heat generated is less than the losses due to radiation and conduction in the workpiece and thermal conduction of the electrodes. The result is the possibility, with long weld times at low currents, of overheating the entire base metal area between the electrodes. This could cause burning of the top and bottom surfaces of the workpiece as well as possibly imbedding the electrode tips in the workpiece surfaces.

As current density is increased, the weld time is decreased proportionately. If, however, the current density becomes too high, there is the possibility of expelling molten metal from the interface of the joint thereby weakening the weld. The ideal time and current density condition is somewhere just below the level of causing metal to be expelled.

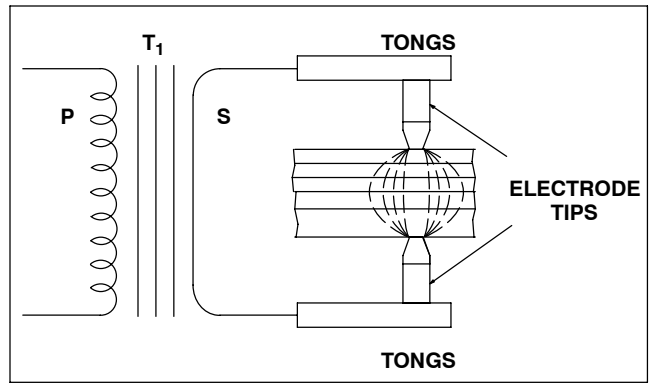

Figure 4-3. Resistance Spot Weld Heat Zones

It is apparent that the heat input cannot be greater than the total dissipation rate of the workpiece and the electrode without having metal expelled from the joint.

An interesting discovery has been developed recently concerning the flow of current through the workpiece. Until recently, current was considered to flow in a straight line through the weld joint. This is not necessarily true when multiple thicknesses of material are being welded. The characteristic is for the current to "fan out" thereby decreasing the current density at the point of weld the greatest distance from the electrode tips. The illustration (Figure 4-3) shows the resistance spot weld heat zones for several thicknesses of metal. We note that the uncontrollable variables (such as interface contamination) are multiplied when resistance spot welding several thicknesses of material. Quality levels will be much lower for "stack" resistance spot welding, which explains why such welding practices are avoided whenever possible.

Disregarding the quality factor, it becomes apparent that the number of thicknesses of a material which may be successfully resistance spot welded at one time will depend on the material type and thickness as well as the KVA capacity of the resistance spot welding machine.

KVA rating, duty cycle, and other pertinent information is shown on all resistance spot welding machine nameplates. The catalog literature and the operating manuals provide data on the maximum combined thicknesses of material that each unit can weld. A table showing the various models of resistance spot welding machines is located in the back of this book.

## 4-7. Electrode Tip Size

When you consider that it is through the electrode that the welding current is permitted to flow into the workpiece, it is logical that the size of the electrode tip point controls the size of the resistance spot weld. Actually, the weld nugget diameter should be slightly less than the diameter of the electrode tip point.

If the electrode tip diameter is too small for the application, the weld nugget will be small and weak. If, however, the electrode tip diameter is too large, there is danger of overheating the base metal and developing voids and gas pockets. In either instance, the appearance and quality of the finished weld would not be acceptable.

To determine electrode tip diameter will require some decisions on the part of the weldment designer. The resistance factors involved for different materials will certainly have some bearing on electrode tip diameter determination. A general formula has been developed for low carbon steel. It will provide electrode tip diameter values that are usable for most applications.

*The TIP DIAMETER discussed in this text refers to the electrode tip diameter at the point of contact with the workpiece. It does not refer to the major diameter of the total electrode tip.*

The formula generally used for low carbon steel is as follows:

$$\text{Electrode tip diameter} = 0.100" + 2t$$

where "t" is the thickness in inches of one thickness of the metal to be welded. This formula is applicable to the welding of metals of dissimilar thicknesses. The formula is applied to each thickness individually, and the proper electrode tip diameter selected for each size of the joint.

For example, if two pieces of 0.062" sheet metal are to be joined, the electrode tip diameter would be the same for both sides of the joint. The calculation would be as follows:

$$\begin{aligned} \text{Electrode tip dia.} &= 0.100 + 2t \\ &= 0.100 + 2 \times 0.062" \\ &= 0.100 + 0.124" \end{aligned}$$

$$\text{Electrode tip dia.} = 0.224"$$

If the two pieces were unequal in thickness, such as one piece 0.062" and the other 0.094", two calculations would have to be made. Each thickness would be treated as the basis for one electrode tip diameter determination, as follows:

$$\begin{aligned} \text{Electrode tip dia.} &= 0.100 + 2t \\ &= 0.100 + 2 \times 0.062" \\ &= 0.100 + 0.124" \end{aligned}$$

$$\text{Electrode tip dia.} = 0.224" \text{ (one side only)}$$

For the other side, the calculation is as follows:

$$\begin{aligned} \text{Electrode tip dia.} &= 0.100 + 2t \\ &= 0.100 + 2 \times 0.094" \\ &= 0.100 + 0.188" \end{aligned}$$

$$\text{Electrode tip dia.} = 0.288" \text{ (one side only)}$$

Remember that the formula is applicable to low carbon steels and may not be correct for other materials.

#### 4-8. Pressure Or Welding Force

The pressure exerted by the tongs and the electrode tips on the workpiece have a great effect on the amount of weld current that flows through the joint. The greater the pressure, the higher the welding current value will be, within the capacity of the resistance spot welding machine.

Setting pressure is relatively easy. Normally, samples of material to be welded are placed between the electrode tips and checked for adequate pressure to make the weld. If more or less pressure is required, the operating manual for the resistance spot welding machine will give explicit directions for making the correct setting. As part of the setting up operation, the tong and electrode tip travel should be adjusted to the minimum required amount to prevent "hammering" the electrode tips and tip holders.

Tables are provided in the appendix of this book to serve as guidelines in making the necessary settings to obtain good resistance spot welding conditions. They should be used as guides only, since some slight variation in the settings may be necessary for a specific application.

#### 4-9. Miscellaneous Data

This section of the text is designed to provide information regarding several of the variables that occur in some resistance spot welding applications.

#### 4-10. Heat Balance

There is no particular problem of heat balance when the materials to be welded are of equal type and thickness. The heat balance, in such cases, is automatically correct if the electrode tips are of equal diameter, type, etc. Heat balance may be defined as the conditions of welding in which the fusion zone of the pieces to be joined are subjected to equal heat and pressure.

When the weldment has parts of unequal thermal characteristics, such as copper and steel, a poor weld may result for several reasons. The metals may not alloy properly at the interface of the joint. There may be a greater amount of localized heating in the steel than in the copper. The reason would be because copper has low electrical resistance and high thermal transfer characteristics, while steel has high electrical resistance and low thermal transfer characteristics.

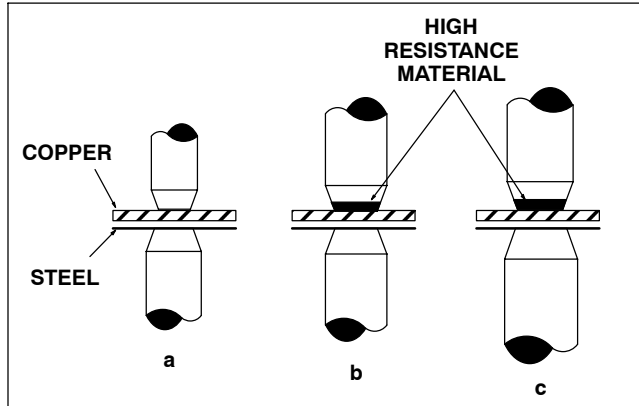

**Figure 4-4. Techniques For Obtaining Heat Balance**

Correct heat balance may be obtained in a weldment of this type by one of several methods. Figure 4-4 illustrates three possible solutions to the problem. Figure 4-4 (a) shows the use of a smaller electrode tip area for the copper side of the joint to equalize the fusion characteristics by varying the current density in the dissimilar materials.

Figure 4-4 (b) shows the use of an electrode tip with high electrical resistance material, such as tungsten or molybdenum, at the contact point. The result is to create approximately the same fusion zone in the copper as in the steel. A combination of the two methods is shown in Figure 4-4 (c).

#### 4-11. Surface Conditions

All metals develop oxides which can be detrimental to resistance spot welding. Some oxides, particularly those of a refractory nature, are more troublesome than others. In addition, the mill scale found on hot-rolled steels will act as an insulator and prevent good quality resistance spot welding. Surfaces to be joined by this process should be clean, free of oxides, chemical compounds, and have a smooth surface.

#### 4-12. Materials Data For Resistance Spot Welding

This section of the text will consider methods used for resistance spot welding some of the common metals that are used in fabrication work. It is not intended that all the possible problems that could arise will be

answered. The purpose of this part of the text is to provide general operational data for use with resistance spot welding machines. Where applicable, the data provided will be related to specific models and size (KVA) of units.

#### 4-13. Mild Steel

Mild or low-carbon steel comprises the largest percentage of material welded with the resistance spot welding process. All low-carbon steels are readily weldable with the process if proper equipment and procedures are used.

The carbon steels have a tendency to develop hard, brittle welds as the carbon content increases if proper post-heating procedures are not used. Quick quenching of the weld, where the nuggets cool rapidly, increases the probability of hard, brittle micro-structure in the weld.

Hot rolled steel will normally have mill scale on the surface of the metal. This type of material is usually not resistance spot welded with resistance welding machines of the KVA ratings of specific built units.

Cold rolled steel (CRS) and hot rolled steel, pickled and oiled (HRSP & O), may be resistance spot welded with very little trouble. If the oil concentration is excessive on the sheet metal, it could cause the formation of carbon at the electrode tips thereby decreasing their useful life. Degreasing or wiping is recommended for heavily oiled sheet stock.

The resistance spot weld should have shear strength equal to the base metal shear strength and should exceed the strength of a rivet or a fusion plug weld of the same cross sectional area. Shear strength is normally accepted as the criteria for resistance spot weld specifications, although other methods may be used.

A common practice is to “peel” two welded sample strips apart to see if a clean “rivet” is pulled from one piece. If it is, the resistance spot welding condition is considered correct.

With magnetic materials such as mild steel, the current through the weld can vary substantially depending on how much of the magnetic material is within the tong loop. The tong loop is sometimes called the “throat” of the resistance spot welding machine.

For example, the part to be welded may have the largest amount of the base metal within the throat of the unit for any one resistance spot weld and almost none of the base metal in the throat for the second spot weld. The current at the weld joint will be less for the first weld. The reason is the reactance caused by the ferrous material within the arc welding circuit.

Resistance spot welding machines are applicable to low carbon steel welding. They must be used within their rated capacity of total thickness of material for best results. They should not be used over the duty cycle since damage to the contactor and transformer may result. The 50 percent duty cycle provided for this type of equipment should be adequate for all applications within their rating. The 50 percent duty cycle is a RWMA standard rating for general duty resistance welding machines. The 50 percent duty cycle is based on a 10 second time period and means the unit can weld 5 seconds out of each 10 second time period.

Table 1 provides the rating information for all models of resistance spot welding machines. The open-circuit voltage and short-circuit current for different tong lengths, etc., are given. The short-circuit current values are according to RWMA test procedures for copper-to-copper contact. The values considered do not have weld metal in between the tips. The combined metal thickness that each model can accommodate is also shown.

#### **4-14. Low Alloy And Medium Carbon Steels**

There are some pertinent differences in resistance spot welding low alloy and medium carbon steels as compared to mild or low carbon steels. The resistance factor for the low alloy and medium carbon steels is higher; therefore, the current requirements are slightly lower. Time and temperature are more critical since metallurgical changes will be greater with these alloys. There is certainly more possibility of weld embrittlement than there is with mild steel.

Resistance spot welding pressures are normally higher with these materials because of the additional compressive strength inherent in the low alloy and medium carbon steels. It is always a good idea to use longer welding times when welding these alloys to retard the cooling rate and permit more ductile welds.

#### **4-15. Stainless Steels**

The chrome-nickel steel alloys (austenitic) have very high electrical resistance and are readily joined by resistance spot welding. The consideration of great importance with these materials is rapid cooling through the critical range, 800° to 1400° F. The rapid quench associated with resistance spot welding is ideal for reducing the possibility of chromium carbide precipitation at the grain boundaries. Of course, the longer the weldment is held at the critical temperatures, the greater the possibility of carbide precipitation.

#### **4-16. Steels, Dip Coated Or Plated**

The overwhelming majority of material in this category is galvanized, or zinc coated steel. Although some

galvanized steel is electro-plated, the dip-coated costs less and is in predominant use. The zinc coating is uneven in thickness on dip-coated steel. The resistance factor will vary from weld to weld, and it is very difficult to set conditions in chart form for the material.

It is impossible to maintain the integrity of the galvanized coating when resistance spot welding. The low melting point of the zinc coating, compared to the fusion temperature of the steel sheet, causes the zinc to vaporize. Of course, there must be adequate pressure to force the zinc aside at the weld interface to permit steel-to-steel fusion. Otherwise, the strength of the resistance spot weld is open to question.

Materials are available to repair the external damage to the coating that may be incurred because of the welding heat. There is no remedy for the loss of coating material at the interfaces of the weld, unfortunately. In fact, the vaporization of the zinc can cause porosity in the weld and a general weakening of the expected shear strength.

▲ The VAPORIZED ZINC, upon condensation to solid material, forms particles shaped like fishhooks. These particles CAN IMBED THEMSELVES IN THE TISSUES OF THE BODY and cause irritation. Use forced ventilation or exhaust at the weld area and wear long sleeve shirts, long pants, and protective face shields when working with this process and coated material.

Other coated material, such as terne plate (lead coated) may have varying degrees of toxicity. Adequate ventilation is mandatory when working with these materials.

The vaporization of the coating material has a tendency to foul the electrode tips. The tips should be cleaned frequently to prevent the alloying of the lower melting materials with the copper tips. The tips may require cleaning and dressing every fourth or fifth weld to maintain quality in the product, although for some galvanized applications the best welds are made after several spots blacken the tips. The use of short weld times will increase the possibility of good welds with the least amount of tip fouling.

#### **4-17. Aluminum And Aluminum Alloys**

Resistance spot welding machines with KVA ratings much greater than 20 KVA are necessary to make sound welds on most aluminum materials and any other high conductivity type of base metal. The electrical conductivity of aluminum is high, and welding machines must provide high currents and exact pressures in order to provide the heat necessary to melt the aluminum and produce a sound weld.

## 4-18. Summary

Resistance spot welding is welding technique that is used for almost all known metals. The actual weld is made at the interface of the parts to be joined. The electrical resistance of the material to be welded causes a localized heating at the interfaces of the metals to be joined. Welding procedures for each type of material must be developed for the most satisfactory results.

It is possible that shunt currents flowing through a previously made spot weld will take welding current away from the second spot weld to be made. This will occur if the two spot welds are too close together, and it will happen with all metals.

The following tables and charts are intended as guides for setting up resistance spot welding procedures. The exact time, pressure, and current setting will depend on the specific application and the KVA rating of the resistance spot welding machine employed. Some areas of the tables may not apply to resistance spot welders in the KVA ratings available from this company.

**Table 4-1. Resistance Spot Welding Machine Specifications**

Model	KVA Rating	Rated Output 6" Tongs	Rated Output 12" Tongs	Rated Output 18" Tongs	Open Circuit Voltage	Max. Capacity** Uncoated Mild Steel, Combined Thickness Using 6" Tongs
MSW-41	1.5	5,550	4,500	3,600	1.6	1/8"
MSW-411*	1.5	5,550	4,500	3,600	1.6	1/8"
MSW-42	1.5	5,550	4,500	3,600	1.6	1/8"
MSW-421*	1.5	5,550	4,500	3,600	1.6	1/8"
LMSW-52	2.5	6,750	5,800	4,850	2.5	3/16"
LMSW-521*	2.5	6,750	5,800	4,850	2.5	3/16"
PSW-1020	10.0	9,500	7,500	6,500	2.5	3/16"
PSW-2020	20.0	12,500	10,500	9,000	3.55	1/4"
SSW-1020	10	9,500	7,500	6,500	2.5	3/16"
SSW-1040	10	9,500	7,500	6,500	2.5	3/16"
SSW-2020	20	12,500	10,500	9,000	3.55	1/4"
SSW-2040	20	12,500	10,500	9,000	3.55	1/4"
**"t" series feature an automatic timer.						
**Ratings are for uncoated mild and low carbon steel with 6" tongs. For other metals, the combined thickness will have to be determined.						

The following general data is provided to assist the operator in setting up welding procedures when using any of the resistance spot welding machines listed in Table 4-1.

Tong pressure settings should be made ONLY when the primary power cord is disconnected from the primary power input supply.

1. Close tongs and measure space between electrode tip contact surfaces.
2. Measure the thickness of the total weldment.
3. Adjust tong gap to measurement of Step 2 less 1/2 the thickness of the thinnest weld number.
4. Insert the parts to be welded between the electrode tips and bring tips to welding pressure. There should be a slight deflection of the tongs. This may be measured with a straight edge set on the tong longitudinal axis.
5. Energize the spot welding machine and make a sample weld.
6. Test the weld by visual and mechanical means. Check the electrode tip for deformation and contamination (see test procedures).
7. Adjust tong pressure as required (see Operating Manual for tong adjustment procedures).

## 4-19. Test Procedures

The test procedures outlined are very simple and require a minimum of equipment to perform.

### 1. Visual Test

Observe the deformation and shape of the surface contact points at both sides of the weld. Excessive "dishing" of the surface contact point indicates one or more of the following:

- a. Excessive tong pressure.
- b. Weld time too long.
- c. Misalignment of the electrode tips.





If the resistance spot weld does not have an even, concentric surface appearance, the problem could be misalignment of the electrode tips. Align electrode tips with the power off and a typical weld joint between the tip surfaces.

### 2. Mechanical Test

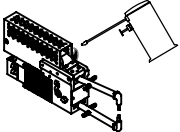
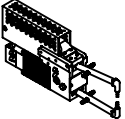

Place one end of the resistance spot weld sample in vice jaws. Use mechanical means to force the weld apart. One side of the weld should pull loose from the parent metal with a metal extension from the weld. Check for proper weld diameter.

# SECTION 5 – MAINTENANCE AND TROUBLESHOOTING

## 5-1. Maintenance

				<p>▲ Disconnect power before maintaining.</p> <p>📅 During heavy service, maintain monthly.</p>	
 <b>3 Months</b>					
	Oil Unit		Inspect Tips		Replace Damaged Or Unreadable Labels

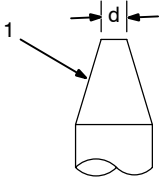
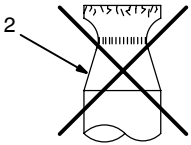
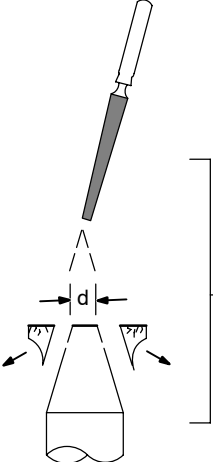
## 5-2. Dressing Tips

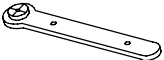
<p><math>d = 3/16 - 1/4</math> in (4.8–6.4 mm) diameter</p>		<ol style="list-style-type: none"> <li>1 New Tip</li> <li>2 Used Tip Requiring Dressing</li> <li>3 Dressing Method – Keep top diameter same as a new tip.</li> </ol>
		
 <p>OR</p> 		

### 5-3. Troubleshooting

Trouble	Remedy
Tips overheating.	Not enough tong pressure. Increase tong pressure.
	Weld time too long. Reduce weld time.
	Material too thick for the spot welding machine.
Tips arcing on material.	Not enough tong pressure. Increase tong pressure.
	Tips not aligned correctly. Realign tips or dress tips to proper diameter (see Section 5-2).
	Base material may be welded to tips causing high resistance and poor electrical current flow. Clean or dress tips (see Section 5-2).
Spatter or molten material being expelled out during welding operation.	Incorrect tip alignment. Dress tips so that they align and are flat on the material (see Section 5-2).
	Excessive tong pressure. Reduce tong pressure.
	Output amperage too high. Reduce amperage setting, if applicable (not available on air-cooled models).
	Weld time too long. Reduce weld time.
Inconsistent weld nugget.	Inconsistent weld time. Install a weld timer, if applicable.
	Not enough tong pressure. Increase tong pressure.
Hole in middle of weld.	Contact area of tips is too large. Change to a smaller tip diameter or dress tips back to original diameter (see Section 5-2).
Poor weld or no weld at tips.	Material too thick for spot welding machine. Check that material thickness is within capacity of spot welding machine.
	Tongs are too long. Reduce tong length.
	Remove coating from material for intimate contact between pieces. Remove oxides and chemical compounds including galvanized coating.



**Miller Electric Mfg. Co.**

An Illinois Tool Works Company  
1635 West Spencer Street  
Appleton, WI 54914 USA

**International Headquarters—USA**

USA Phone: 920-735-4505 Auto-Attended  
USA & Canada FAX: 920-735-4134  
International FAX: 920-735-4125

**European Headquarters –  
United Kingdom**

Phone: 44 (0) 1204-593493  
FAX: 44 (0) 1204-598066

