

# **UNIFIED FACILITIES CRITERIA (UFC)**

## **SOLID WASTE DISPOSAL**



**APPROVED FOR PUBLIC RELEASE; DISTRIBUTION UNLIMITED**

**UNIFIED FACILITIES CRITERIA (UFC)**

**SOLID WASTE DISPOSAL**

Any copyrighted material included in this UFC is identified at its point of use. Use of the copyrighted material apart from this UFC must have the permission of the copyright holder.

U.S. ARMY CORPS OF ENGINEERS

NAVAL FACILITIES ENGINEERING COMMAND (Preparing Activity)

AIR FORCE CIVIL ENGINEER SUPPORT AGENCY

Record of Changes (changes are indicated by \1\ ... /1/)

| <b>Change No.</b> | <b>Date</b>     | <b>Location</b> |
|-------------------|-----------------|-----------------|
| <u>1</u>          | <u>Dec 2005</u> | <u>FOREWORD</u> |
|                   |                 |                 |

---

This UFC supersedes NAVFAC Design Manual 5.10, dated September 1989.

## CONTENTS

|  | Page |
|--|------|
| CHAPTER 1 INTRODUCTION                     |      |
| Paragraph 1-1 PURPOSE AND SCOPE .....      | 1-1  |
| 1-2 APPLICABILITY .....                    | 1-1  |
| 1-2.1 General Building Requirements .....  | 1-1  |
| 1-2.2 Safety .....                         | 1-1  |
| 1-2.3 Fire Protection .....                | 1-1  |
| 1-2.4 Antiterrorism/Force Protection ..... | 1-1  |
| APPENDIX A DESIGN MANUAL 5.10.....         | A-1  |

## CHAPTER 1

### INTRODUCTION

1-1 **PURPOSE AND SCOPE.** This UFC is comprised of two sections. Chapter 1 introduces this UFC and provides a listing of references to other Tri-Service documents closely related to the subject. Appendix A contains the full text copy of the previously released Design Manual (DM) on this subject. This UFC serves as criteria until such time as the full text UFC is developed from the Design Manual and other sources.

This UFC provides general criteria for designing solid waste disposal.

Note that this document does not constitute a detailed technical design, and is issued as a general guide to the considerations associated with designing solid waste disposal.

1-2 **APPLICABILITY.** This UFC applies to all Navy service elements and Navy contractors; Army service elements should use the references cited in paragraph 1-3 below; all other DoD agencies may use either document unless explicitly directed otherwise.

1-2.1 **GENERAL BUILDING REQUIREMENTS.** All DoD facilities must comply with UFC 1-200-01, *Design: General Building Requirements*. If any conflict occurs between this UFC and UFC 1-200-01, the requirements of UFC 1-200-01 take precedence.

1-2.2 **SAFETY.** All DoD facilities must comply with DODINST 6055.1 and applicable Occupational Safety and Health Administration (OSHA) safety and health standards.

**NOTE:** All **NAVY** projects, must comply with OPNAVINST 5100.23 (series), *Navy Occupational Safety and Health Program Manual*. The most recent publication in this series can be accessed at the NAVFAC Safety web site:

[www.navfac.navy.mil/safety/pub.htm](http://www.navfac.navy.mil/safety/pub.htm). If any conflict occurs between this UFC and OPNAVINST 5100.23, the requirements of OPNAVINST 5100.23 take precedence.

1-2.3 **FIRE PROTECTION.** All DoD facilities must comply with UFC 3-600-01, *Design: Fire Protection Engineering for Facilities*. If any conflict occurs between this UFC and UFC 3-600-01, the requirements of UFC 3-600-01 take precedence.

1-2.4 **ANTITERRORISM/FORCE PROTECTION.** All DoD facilities must comply with UFC 4-010-01, *Design: DoD Minimum Antiterrorism Standards for Buildings*. If any conflict occurs between this UFC and UFC 4-010-01, the requirements of UFC 4-010-01 take precedence.

**APPENDIX A**

**DESIGN MANUAL 5.10  
SOLID WASTE DISPOSAL**



NAVFAC DM/P MANUAL DISTRIBUTION (01/87):  
(1 copy each unless otherwise specified)  
SNDL

398 COMCB  
49 ADMSUPPU  
A2A NAVY STAFF (ONR only)  
A3 CHIEF OF NAVAL OPERATIONS  
A5 NAVPERS & BUMED  
A6 COMMANDANT MC (code LFF)  
B2A (JCS, NSA, DLA, DNA only)  
65 USCG only)  
E3A LAB ONR(Wash.DC only)  
FA6 NAVAIRSTA LANT  
FA7 NAVSTA LANT  
FA10 SUB BASE LANT  
FA18 PHIBASE LANT  
FA23 NAVFAC LANT  
FA32 CINCLANT CBU  
FB6 NAVAIRFAC PAC  
FB7 NAVAIRSTA PAC  
FB10 NAVSTA PAC (Seattle only)  
FB13 SUBASE PAC (Bangor only)  
FB21 PHIBASE PAC  
FB34 FLEACTPAC (Kadena,Sasebo only)  
FB36 FAC PAC  
FB48 SUPPFAC PAC  
FC3 ACTIVITY EUR (London only)  
FC5 SUPPORT ACTIVITY EUR  
FC7 NAVAL STATION EUR  
FC12 FLEET SUPPORT OFFICE  
FC14 NAVAIRSTA EUR  
FD1 OCEANOGRAPHY COMM  
FE1 SECURITY GROUP HQ  
FE2 SECURITY STATION  
FE4 SECGRUACT (Edzell, Hanza  
Homestead, Sabana Seca,  
Sonoma, Winter Harbor only)  
FF6 NAVAL OBSERVATORY  
FF38 NAVAL ACADEMY  
FG1 TELECOMMCOM  
FG2 COMSTA (Balboa, Harold Holt,  
Nea Makri, Thurso, Stockton,  
Yokosuka, San Miguel only)  
FG3 COWI UNIT (East Machias only)  
FG6 CA MASTER STAS (Norfolk only)  
FH1 COMNAVMECOM  
FKALA SYSCOM, AIR  
FKALB SYSCOM, ELEX  
FKALC NAVFAC,(Code 04M2, 30 copies)  
FKALF SYSCOM, SUP  
FKALG SYSCOM, SEA  
FKM8 SUPPLY ANNEX  
FKM9 NSC (Oakland only)  
FKM13 SHIPS PARTS & CONTROL CEN  
FKM15 ASO (Philadelphia only)  
FKN1 LANTDIV (100 copies)  
CHESDIV ( 50 copies)  
NORTHDIV (75 copies)  
PACDIV, SOUTHDIV,  
WESTDIV, (200 copies each)

FKN2 CBC  
FKN3 OICC (6 copies each)  
FKN5 PWC (5 copies each)  
FKN7 ENERGY ENVIRON SUPP ACT  
FKN10 SUPPORT ACT, NAV FAC  
FKN11 CIVIL ENGINEERING LAB  
FKP1B WEAPONS STATION  
FKP1E UNDERSEA WARFARE ENGR STA  
FKP1J NAVAL ORDNANCE STATION  
FKP1M WEAPONS SUPPLY CENTER  
FKP7 NAVAL SHIPYARDS  
FKQ3A ELECTRONIC SIMS ENGR CEN  
FKQ6A AIR DEVELOPMENT CENTER  
FKQ6B COASTAL SYSTEMS CENTER  
FKQ6C OCEAN SYSTEMS CENTER  
FKQ6E SHIP RESEARCH 6 DEV.CEN.  
FKQ6F SURFACE WEAPONS CENTER  
FKQ6G UNDERWATER SYSTEMS CENTER  
FKQCH NAVAL WEAPONS CENTER  
FKR1A AIR STATIONS R&D  
FKR1B AIR REWORK FACILITY  
FKR3A AIR ENGINEERING CENTER  
FKR3H AIR PROPULSION CENTER  
FKR4B MISSILE RANGE FACILITY  
FKR5 AVIONICS CENTER  
FKR7E AVIATION LOGISTICS CENTER  
FR3 AIR STATIONS  
FR4 AIR FACILITIES  
FR15 SUPPACT  
FT1 CHIEF NAVAL ENGR. TRAINING  
FT2 CHIEF NAVAL AIR TRAINING  
FT6 AIR STATIONS CNET  
FT13 AIR TECH TRAINING CEN  
FT18 CONSTR. BATTALION UNIT CBC  
FT19 ADMINCOM (San Diego only)  
FT22 FLECOMBATRACEN (Va. Beach only)  
FT28 EDUCATION 6, TRAINING CEN  
FT31 TRAINING CENTER  
FT37 SCHOOL CEC OFFICERS  
FT55 SCHOOL SUPPLY CORPS  
FT78 ED 6 TRNG PGM DEV CEN  
v2 MARCORPS BARRACKS SUPPORT  
v3 MC AIR BASE COWLAND  
v5 MCAS (less Beaufort)  
v5 MCAS (Beaufort only,5 cys)  
V8 MC RECRUIT DEPOT  
v12 MC DEVELOP.& EDUCATION CEN  
v14 MC HEADQUARTERS BATTALION  
v15 MC DISTRICT  
v17 MC CAMP  
V23 MC LOGISTICS BASE  
V25 MC AIR GROUND COMBAT C1 N

REMAINDER TO: RECEIVING OFFICER  
Naval Publications and Forms Center  
5801 Tabor Avenue, Phila., PA 19120  
FOR IMMEDIATE STOCK

Information on how to obtain additional  
copies is contained in References.

# RECORD OF DOCUMENT CHANGES

Instructions: DISCARD EXISTING SHEET AND INSERT THIS NEW RECORD OF DOCUMENT CHANGES.

This is an inventory of all changes made to this design manual. Each change is consecutively numbered, and each changed page in the design manual includes the date of the change which issued it.

| Change<br>Number   | Description<br>of Change | Date of<br>Change | Page<br>Number |
|--|--------------------------|-------------------|----------------|
| AA |                          |                   |                |

## ABSTRACT

Information in this manual is for use by qualified engineers in selection and design of a base-specific disposal method of solid waste. term "solid waste" in this manual is defined by the Environmental Protection Agency in accordance with 40 CFR 257, Regulations on Criteria for Classification of Solid Waste Disposal Facilities and Practices, 1982.



## FOREWORD

This design manual is one of a series of civil engineering design manuals developed for Navy use. The contents of this manual are based on accepted current state-of-the-art practices and governmental agency regulation. This manual incorporates, to the maximum extent feasible, national professional society, association, and institute standards in accordance with NAVFACENGCOM policy. Deviations from these criteria should not be made without prior approval of NAVFACENGCOM HQ (Code 04K2).

As state-of-the-art practices and regulations change, the changes should be reflected in the manual. Accordingly, recommendations for revisions are encouraged from within the Navy and from the private sector. These recommendations should be furnished to Commander, Pacific Division, Code 406, Naval Facilities Engineering Command, Pearl Harbor, HI 96860 for review and for ultimate incorporation into the manual as appropriate.

This publication is certified as an official publication of the Naval Facilities Engineering Command and has been reviewed and approved in accordance with SECNAVINST 5600.16A, Review of Department of the Navy (DN) Publications; Procedures Governing.

J. P. JONES, JR.  
Rear Admiral, CEC, U.S. Navy  
Commander  
Naval Facilities Engineering Command

## CIVIL ENGINEERING DESIGN MANUALS

| Number<br>AAAAAA | Title<br>AAAAA   |
|------------------|--|
| 5.01             | Surveying  |
| 5.02             | Hydrology  |
| 5.03             | Drainage Systems   |
| 5.04             | Pavements  |
| 5.05             | General Provisions and Geometric Design for Roads,<br>Streets, Walks, and Open Storage Areas |
| 5.06             | Trackage   |
| 5.07             | Water Supply Systems   |
| 5.08             | Domestic Wastewater Control  |
| 5.09             | Industrial and Oily Wastewater Control   |
| 5.10             | Solid Waste Disposal   |
| 5.12             | Fencing, Gates, and Guard Towers   |
| *5.13            | Hazardous Waste Storage and Transfer Facilities  |
| 5.14             | Groundwater Pollution Control  |

\* DM has been cancelled and interim criteria issued - will be published a Military Handbook.

# CIVIL ENGINEERING SOLID WASTE DISPOSAL

## CONTENTS

|                  | Page   |
|------------------|--|
|                  | ÄÄÄÄ   |
| <b>Section 1</b> | <b>PRELIMINARY DATA . . . . . 5. 10</b>  |
| 1.1              | Scope . . . . . 5. 10-   |
| 1.2              | Cancellation. . . . . 5. 10-   |
| 1.3              | Related Criteria. . . . . 5. 10-   |
| 1.4              | Policies. . . . . 5. 10-   |
| 1.4.1            | Federal, State, and Local Guidelines and<br>Regulations . . . . . 5-10-              |
| 1.4.2            | Solid Waste Segregation . . . . . 5. 10-   |
| 1.4.3            | Municipal Contractor. . . . . 5. 10-   |
| 1.4.4            | Joint Military Operations . . . . . 5. 10-   |
| <b>Section 2</b> | <b>PLANNING FOR SOLID WASTE MANAGEMENT AT NAVY<br/>INSTALLATIONS. . . . . 5. 10-</b> |
| 2.1              | Introduction. . . . . 5. 10-   |
| 2.2              | Solid Waste Characteristics . . . . . 5. 10-   |
| 2.3              | Collection and Hauling Options . . . . . 5. 10-                                      |
| 2.3.1            | Direct Haul . . . . . 5. 10-   |
| 2.3.2            | Transfer . . . . . 5. 10-  |
| 2.4              | Resource Recovery . . . . . 5. 10-   |
| 2.5              | Solid Waste Disposal. . . . . 5. 10-   |
| <b>Section 3</b> | <b>SOLID WASTE CHARACTERISTICS . . . . . 5. 10</b>                                   |
| 3.1              | Introduction . . . . . 5. 10-  |
| 3.2              | Solid Waste Types . . . . . 5. 10-   |
| 3.3              | Waste Quantities. . . . . 5. 10-   |
| <b>Section 4</b> | <b>SOLID WASTE STORAGE AND COLLECTION . . . . . 5. 10</b>                            |
| 4.1              | Introduction . . . . . 5. 10-  |
| 4.2              | Solid Waste Storage . . . . . 5. 10-   |
| 4.2.1            | Onsite Solid Waste. . . . . 5. 10-   |
| 4.2.2            | Solid Waste from Foreign Sources. . . . . 5. 10-                                     |
| 4.3              | Solid Waste Collection Vehicles . . . . . 5. 10-                                     |
| 4.3.1            | Principal Types of Vehicles . . . . . 5. 10-   |
| 4.3.1.1          | Waste-Haul Vehicles . . . . . 5-10-  |
| 4.3.1.2          | Container-Haul Vehicles . . . . . 5-10-  |
| <b>Section 5</b> | <b>SOLID WASTE TRANSFER . . . . . 5. 10</b>  |
| 5.1              | Introduction . . . . . 5-10-   |
| 5.2              | Types of Transfer Stations . . . . . 5. 10-  |
| 5.2.1            | Noncompaction Systems . . . . . 5. 10-   |
| 5.2.1.1          | Direct Dump . . . . . 5-10-  |
| 5.2.1.2          | Dump to Storage Pit . . . . . 5-10-  |

|                  | Page  |
|------------------|---|
|                  | AAA   |
| 5.2.1.3          | Dump to Tipping Floor . . . . . 5.10-   |
| 5.2.2            | Compaction Systems . . . . . 5.10-  |
| 5.3              | Environmental Impacts . . . . . 5.10-   |
| 5.3.1            | Noise . . . . . 5.10-   |
| 5.3.2            | Air Quality . . . . . 5.10-   |
| 5.3.3            | Odors . . . . . 5.10-   |
| 5.3.4            | Traffic Congestion. . . . . 5.10-   |
| 5.3.5            | Litter. . . . . 5.10-   |
| 5.3.6            | Water Contamination . . . . . 5.10-   |
| 5.4              | Transfer Station Siting . . . . . 5.10-   |
| 5.5              | Transfer Station Costs. . . . . 5.10-   |
| <b>Section 6</b> | <b>SOLID WASTE PROCESSING AND VOLUME REDUCTION</b>  |
|                  | <b>CONVERSION</b> . . . . . 5.10-   |
| 6.1              | Solid Waste Processing operations . . . . . 5.10-   |
| 6.1.1            | Source Separation/Recycling . . . . . 5.10-   |
| 6.1.2            | Size Reduction. . . . . 5.10-   |
| 6.1.3            | Air Classification. . . . . 5.10-   |
| 6.1.4            | Screening . . . . . 5.10-   |
| 6.1.5            | Magnetic Separation . . . . . 5.10-   |
| 6.1.6            | Densification . . . . . 5.10-   |
| 6.1.7            | Baling. . . . . 5.10-   |
| 6.2              | Solid Waste Conversion Technologies . . . . . 5.10-   |
| 6.2.1            | Incineration/Energy Recovery. . . . . 5.10-   |
| 6.2.2            | Gasification . . . . . 5.10-  |
| 6.2.3            | Composting. . . . . 5.10-   |
| 6.3              | Costs . . . . . 5.10-   |
| <b>Section 7</b> | <b>SANITARY LANDFILLS.</b> . . . . 5.10   |
| 7.1              | Introduction. . . . . 5.10-   |
| 7.2              | Site Selection. . . . . 5.10-   |
| 7.2.1            | Site Life and Size. . . . . 5.10-   |
| 7.2.2            | Location in Relation to Waste Generation<br>Centers . . . . . 5.10-   |
| 7.2.3            | Topography. . . . . 5.10-   |
| 7.2.4            | Surface Water and Susceptibility to Flooding. . . 5.10-   |
| 7.2.5            | Soils . . . . . 5.10-   |
| 7.2.6            | Geology . . . . . 5.10-   |
| 7.2.7            | Groundwater . . . . . 5.10-   |
| 7.2.8            | Vegetation. . . . . 5.10-   |
| 7.2.9            | Site Proximity and Accessibility. . . . . 5.10-   |
| 7.3              | Land Use in Area, Including Future Land Use<br>Classification by the Respective Planning<br>Jurisdiction(s) . . . . . 5.10- |

|         |   |       |
|---------|---|-------|
| 7.3.1   | Archaeological or Historical Significance . . . . . | 5.10- |
| 7.3.2   | Susceptibility to Flooding. . . . .                 | 5.10- |
| 7.3.3   | Public Health and Safety. . . . .                   | 5.10- |
| 7.3.3.1 | Attractive Nuisance . . . . .                       | 5.10- |
| 7.3.3.2 | Bird Hazards. . . . .                               | 5.10- |
| 7.3.4   | Costs . . . . .                                     | 5.10- |
| 7.3.5   | Site Selection Methodology. . . . .                 | 5.10- |
| 7.4     | Sanitary Landfill Design. . . . .                   | 5.10- |
| 7.4.1   | Introduction. . . . .                               | 5.10- |
| 7.4.2   | Regulations and Permits . . . . .                   | 5.10- |
| 7.4.3   | Design Methodology and Data Compilation . . . . .   | 5.10- |
| 7.4.4   | Design Features . . . . .                           | 5.10- |
| 7.4.4.1 | Area Method . . . . .                               | 5.10- |
| 7.4.4.2 | Trench Method . . . . .                             | 5.10- |
| 7.4.5   | Environmental Safeguards. . . . .                   | 5.10- |
| 7.4.5.1 | Leachate Generation . . . . .                       | 5.10- |
| 7.4.5.2 | Landfill Gas. . . . .                               | 5.10- |
| 7.4.5.3 | Odors . . . . .                                     | 5.10- |
| 7.4.5.4 | Noise . . . . .                                     | 5.10- |
| 7.4.5.5 | Air Pollution . . . . .                             | 5.10- |
| 7.4.5.6 | Fires . . . . .                                     | 5.10- |
| 7.4.5.7 | Vectors . . . . .                                   | 5.10- |
| 7.4.5.8 | Storm Water Management. . . . .                     | 5.10- |
| 7.4.5.9 | Access Roads. . . . .                               | 5.10- |
| 7.4.6   | Soil Availability . . . . .                         | 5.10- |
| 7.4.7   | Special Working Areas . . . . .                     | 5.10- |
| 7.4.8   | Buildings and Structures. . . . .                   | 5.10- |
| 7.4.9   | Aesthetics. . . . .                                 | 5.10- |
| 7.4.10  | Scales. . . . .                                     | 5.10- |
| 7.4.11  | Utilities . . . . .                                 | 5.10- |
| 7.4.12  | Fencing . . . . .                                   | 5.10- |
| 7.4.13  | Lighting. . . . .                                   | 5.10- |
| 7.4.14  | Wash Rack . . . . .                                 | 5.10- |
| 7.4.15  | Landscaping . . . . .                               | 5.10- |
| 7.5     | Equipment . . . . .                                 | 5.10- |
| 7.5.1   | Introduction. . . . .                               | 5.10- |
| 7.5.2   | Equipment Types and Characteristics . . . . .       | 5.10- |
| 7.5.2.1 | Track Machines. . . . .                             | 5.10- |
| 7.5.2.2 | Rubber-Tired Machines . . . . .                     | 5.10- |
| 7.5.2.3 | Landfill Compactors . . . . .                       | 5.10- |
| 7.5.2.4 | Scrapers. . . . .                                   | 5.10- |
| 7.5.2.5 | Draglines . . . . .                                 | 5.10- |
| 7.5.3   | Equipment Selection . . . . .                       | 5.10- |
| 7.6     | Closure and Postclosure . . . . .                   | 5.10- |
| 7.7     | Personnel . . . . .                                 | 5.10- |
| 7.8     | Management. . . . .                                 | 5.10- |
| 7.9     | Costs . . . . .                                     | 5.10- |
| 7.9.1   | Capital Costs . . . . .                             | 5.10- |
| 7.9.2   | Operating Costs . . . . .                           | 5.10- |

## FIGURES

|    |   | Page<br>ÄÄÄÄ |
|----|---|--------------|
| 1  | Navy Installation Solid Waste Generation Rates. . . . .   | 5. 10-       |
| 2  | Compactor Trucks. . . . .   | 5. 10-       |
| 3  | Container Haul Trucks . . . . .   | 5. 10-       |
| 4  | Direct Dump to Trailer Transfer Station . . . . .   | 5. 10-       |
| 5  | Direct Dumping to Tipping Floor Transfer Station. . . . .   | 5. 10-       |
| 6  | Illustration of Direct Haul versus Transfer Haul<br>Cost Comparison Curves. . . . .   | 5. 10-       |
| 7  | Example of System Configuration for Recovering<br>Ferrous Scrap and Refuse-Derived Fuel from<br>Municipal Solid Waste . . . . . | 5. 10-       |
| 8  | Horizontal Hammermill . . . . .   | 5. 10-       |
| 9  | Types of Air Classifiers. . . . .   | 5. 10-       |
| 10 | Types of Magnetic Separation Systems. . . . .   | 5. 10-       |
| 11 | Modular Heat Recovery Incineration System . . . . .   | 5. 10-       |
| 12 | Turned Windrow Composting Operation . . . . .   | 5. 10-       |
| 13 | Formula for Determining Landfill Area Requirement . . . . .   | 5. 10-       |
| 14 | Landfill Constructed on Flat Terrain. . . . .   | 5. 10-       |
| 15 | Landfill Cell Lift Sequencing Diagram . . . . .   | 5. 10-       |
| 16 | Area Method Disposal Plan . . . . .   | 5. 10-       |
| 17 | Trench Method Disposal Plan . . . . .   | 5. 10-       |
| 18 | Leachate Control System . . . . .   | 5. 10-       |
| 19 | Landfill Gas Monitoring Well. . . . .   | 5. 10-       |
| 20 | Passive Trench Landfill Gas Control System. . . . .   | 5. 10-       |
| 21 | Typical Membrane Barrier Systems. . . . .   | 5. 10-       |
| 22 | Landfill Gas Extraction Well. . . . .   | 5. 10-       |
| 23 | Active Landfill Gas Control System - Outside of<br>Landfill. . . . .  | 5. 10-       |
| 24 | Example Calculation for Determining Injection/<br>Extraction Well Spacing . . . . .   | 5. 10-       |
| 25 | Landfill Earthmoving/Compaction Equipment . . . . .   | 5. 10-       |
| 26 | Final Landfill Surface for Leachate Control . . . . .   | 5. 10-       |
| 27 | Capital Cost Worksheet. . . . .   | 5. 10-       |
| 28 | Landfill Cost Data Sheet . . . . .  | 5. 10-       |
| 29 | Operating Costs . . . . .   | 5. 10-       |
| 30 | Total Cost Per Unit of Solid Waste. . . . .   | 5. 10-       |

## TABLES

|   |  |        |
|---|--|--------|
| 1 | State Environmental Agencies for Sanitary<br>Landfill Regulation and Permit Matters. . . . . | 5. 10- |
| 2 | Approximate Percentage of Solid Waste by Source . . . . .                                    | 5. 10- |
| 3 | Average Daily Solid Waste Generation Rates from<br>Family Housing Areas . . . . .            | 5. 10- |

|    |   |        |
|----|---|--------|
| 4  | Summary of Emission Factors for Various Navy<br>Installation Sources. . . . .                       | 5. 10- |
| 5  | Example Composition of Municipal Solid Waste. . . . .   | 5. 10- |
| 6  | Reported Solid Waste Generation Rates from Various<br>Sources . . . . .                             | 5. 10- |
| 7  | Types of Containers for Onsite Solid Waste Storage. . . . .   | 5. 10- |
| 8  | Transfer Station Summary Table. . . . .   | 5. 10- |
| 9  | Example Transfer Station Site Rating Evaluation . . . . .   | 5. 10- |
| 10 | Solid Waste Processing Operations . . . . .   | 5. 10- |
| 11 | Estimated Costs of Refuse Processing and Conversion<br>Operations . . . . .                         | 5. 10- |
| 12 | Ranking of USCS Soil Types According to Performance<br>of Landfill Cover Functions . . . . .        | 5. 10- |
| 13 | Soil Characteristics Pertinent to Solid Waste<br>Landfills, USCS . . . . .                          | 5. 10- |
| 14 | Attenuation Properties of Representative Soil . . . . .   | 5. 10- |
| 15 | Typical Local Regulatory Agencies Having<br>Responsibility for Sanitary Landfill Practices. . . . . | 5. 10. |
| 16 | Solid Waste Landfill Design Checklist . . . . .   | 5. 10- |
| 17 | Sources of Existing Information . . . . .   | 5. 10- |
| 18 | Field Investigation for New Information . . . . .   | 5. 10- |
| 19 | Topics Typically Described in a Conceptual Design<br>Report . . . . .                               | 5. 10- |
| 20 | Advantages and Disadvantages of the Area and<br>Trench Method Landfilling Techniques. . . . .       | 5. 10- |
| 21 | Materials Used for Landfill Liners. . . . .   | 5. 10- |
| 22 | Leachate Treatment Methods. . . . .   | 5. 10- |
| 23 | Control Techniques for Landfill Gas (LFG) . . . . .   | 5. 10- |
| 24 | Some Vegetation Found to Be Tolerant to Landfill<br>Environments . . . . .                          | 5. 10- |
| 25 | Waste Handling and Compaction Equipment Sizing. . . . .   | 5. 10- |
| 26 | End Uses for Landfill Sites . . . . .   | 5. 10- |
| 27 | Required Components of a Closure Plan Report. . . . .   | 5. 10- |
|    | REFERENCES . . . . .  | 5. 10- |
|    | INDEX . . . . .   | 5. 10- |

## Section 1: PRELIMINARY DATA

1.1 Scope. This manual provides guidance to engineers for design of disposal facilities and associated systems to handle solid waste generated at Navy shore installations. As defined in the Environmental Protection Agency (EPA), Criteria for Classification of Solid Waste Disposal Facilities and Practices, 40 CFR 257, solid waste is:

"Any garbage, refuse, sludge from a waste treatment plant, water supply treatment plant, or air pollution control facility and other discarded material, including solid, liquid, semi solid, or contained gaseous material resulting from industrial, commercial, mining, and agricultural operations, and from community activities, but does not include solid or dissolved material in domestic sewage, or solid or dissolved materials in irrigation return flows or industrial discharges which are point-sources subject to permits under Section 402 of the Clean Water Act, as amended (86 Stat. 880), or source, special nuclear, or by-product material as defined by the Atomic Energy Act of 1954, as amended (68 Stat. 923)."

Hazardous wastes, as described in Subtitle C of Public Law 94-580, Resource Conservation and Recovery Act of 1976 (RCRA), are not discussed.

Solid wastes are typically handled and disposed of in one or more of several ways, including shredding, baling, source separation, recycling, composting, pyrolysis, incineration and heat recovery, and land disposal (e.g., sanitary landfill). Ocean disposal is also permissible, although obtaining a permit is difficult. There are currently no ocean sites permitted for solid waste disposal.

The term "disposal" is used to identify the point where the Navy relinquishes control of its solid waste or provides for its ultimate disposal. Only land disposal is a practical ultimate disposal method. Other disposal or handling systems, except ocean disposal, reduce the initial volume of solid waste, but leave varying amounts of residues that must be deposited in a controlled land disposal facility. This manual addresses each of the above disposal methods, except ocean disposal, with the emphasis on sanitary landfilling. Furthermore, the focus on landfill is for the handling of family housing and other nonhazardous installation wastes. The practices outlined are applicable to solid waste in general, and the document can be used for guidance in disposing of any of the previously mentioned solid wastes.

1.2 Cancellation. This manual, NAVFAC DM-5.10, Solid Waste Disposal, cancels and supersedes the previous DM-5.10 manual dated October, 1979.

1.3 Related Criteria. Other NAVFAC criteria related to solid waste disposal appear elsewhere in the NAVFAC Design Manual Series as cited below.

| Subject<br>AAAAAAA  | Source<br>AAAAAA |
|---|------------------|
| Incinerators  | MIL-HDBK-1003/2  |
| Surveying   | DM-5.01          |
| Hydrology   | DM-5.02          |
| Drainage Systems  | DM-5.03          |
| Pavements   | DM-5.04          |
| General Provisions and Geometric Design<br>for Roads, Streets, Walks, and Open<br>Storage Areas | DM-5.05          |
| Domestic Wastewater Control   | DM-5.08          |
| Industrial and Oily Wastewater Control  | DM-5.09          |
| Fencing, Gates, and Guard Towers  | DM-5.12          |
| Hazardous Waste Storage and Transfer<br>Facilities  | Interim Criteria |
| Groundwater Pollution Control   | DM-5.14          |

1.4 Policies. Solid waste disposal policies shall be governed by the guidelines and regulations in paragraphs 1.4.1 through 1.4.4.

1.4.1 Federal, State, and Local Guidelines and Regulations. Applicable federal solid waste guidelines and regulations are contained in Environmental Protection Agency (EPA) criteria in the following Code of Federal Regulations (CFR):

|            |  |
|------------|--|
| 40 CFR 240 | Guidelines for the Thermal Processing of Solid Wastes.   |
| 40 CFR 241 | Guidelines for the Land Disposal of Solid Wastes.  |
| 40 CFR 243 | Guidelines for the Storage and Collection of Residential, Commercial, and Institutional Solid Waste. |

|            |  |
|------------|--|
| 40 CFR 245 | Promulgation Resources Recovery Facilities Guidelines.                               |
| 40 CFR 247 | Guidelines for Procurement of Products that Contained Recycled Material.             |
| 40 CFR 255 | Identification of Regions and Agencies for Solid Waste Management.                   |
| 40 CFR 256 | Guidelines for Development and Implementation of State Solid Waste Management Plans. |
| 40 CFR 257 | Criteria for Classification of Solid Waste Disposal Facilities and Practices.        |

Each Navy facility must conform to these federal and to all state and local government guidelines and regulations. Additionally, they must comply with OPNAVINST 5090.1, Environment and Natural Resources Protection Manual, and with DOD Directive 4165.60, Solid Waste Management - Collection, Disposal, Resource Recovery and Recycling Program, October 1976 (Programs and L), as well as conform to NAVFAC MO-213, Solid Waste Management.

A list of agencies responsible for solid waste disposal operations in each state is provided in Table 1. It is important to coordinate all solid waste disposal activities with state and local enforcement agencies to assure regulation compliance and efficient disposal operations.

1.4.2 Solid Waste Segregation. Solid wastes can be segregated at the source, at transfer stations, and at the disposal area for subsequent sale as secondary materials. Newspapers, office paper, metals, and glass are typically segregated for sale in source separation programs. Segregation wastes at the source of generation can be more cost-effective at military installations than in civilian communities because the participation of a solid waste generators can be mandated by installation leaders. When the Defense Property Disposal Office, which is an office under the Defense Logistics Agency of the Department of Defense, sells segregated solid wastes, the activity receives the proceeds.

1.4.3 Municipal Contracts. Contracts with municipalities or private industry can be arranged to allow either disposal of Navy solid waste at offsite waste disposal facilities or disposal of offsite solid waste at installation disposal facilities. The former method of disposal is favored where the cost of disposal is equal to or less than the cost of building operating onsite disposal facilities.

1.4.4 Joint Military Operations. Where several Department of Defense (DOD) activities are concentrated in a metropolitan area, and where municipal operations are not available, joint operation of disposal facilities shall be considered. Such cooperation often allows more sophisticated, economically sized, and safe disposal facilities with advanced design and operation characteristics. A centralized control group having authority to establish rules governing solid waste disposal practices should be established if joint operation is implemented.

Table 1  
 State Environmental Agencies for Sanitary Landfill  
 Regulation and Permit Matters

|   |  |  |
|---|--|--|
| <p><b>ALABAMA</b></p> <p>Alabama Department of Environmental Management<br/>           Land Division<br/>           State Office Building<br/>           Montgomery, Alabama 36104<br/>           (205) 834-1303</p>  | <p><b>COLORADO</b></p> <p>Department of Health<br/>           4210 East Eleventh Street<br/>           Denver, Colorado 80220<br/>           (303) 320-8333</p> <p><b>CONNECTICUT</b></p> <p>Department of Environmental Protection<br/>           Solid Waste Management Program<br/>           122 Washington Street<br/>           Hartford, Connecticut 06106<br/>           (203) 566-3672</p> <p><b>DELAWARE</b></p> <p>Department of Resources and Environmental Control<br/>           Solid Waste Section<br/>           P.O. Box 1401<br/>           Edward Tatnall Building<br/>           Dover, Delaware 19901<br/>           (302) 736-4781</p> <p><b>DISTRICT OF COLUMBIA</b></p> <p>Department of Environmental Services<br/>           RCRA Inventories<br/>           415 12th Street, NW.<br/>           Washington, DC 20004<br/>           (202) 767-8192</p> | <p><b>FLORIDA</b></p> <p>Department of Environmental Regulation<br/>           Solid Waste Management Program<br/>           Twin Towers Office Building<br/>           2600 Blairstone Road<br/>           Tallahassee, Florida<br/>           (904) 488-0300</p> <p><b>GEORGIA</b></p> <p>Environmental Protection Division<br/>           Land Protection Branch<br/>           270 Washington Street, SW.<br/>           Room 822<br/>           Atlanta, Georgia 30334<br/>           (404) 656-2836</p> <p><b>HAWAII</b></p> <p>State Department of Health<br/>           P.O. Box 3378<br/>           Honolulu, Hawaii 96801<br/>           (808) 548-6410</p> <p><b>IDAHO</b></p> <p>Department of Health and Welfare<br/>           Solid Waste Management Section<br/>           State House<br/>           Boise, Idaho 83720<br/>           (208) 334-4107</p> |
| <p><b>ALASKA</b></p> <p>Department of Environmental Conservation<br/>           Land Management<br/>           Mail Pouch 0<br/>           Juneau, Alaska 99811<br/>           (907) 465-2600</p> <p><b>ARIZONA</b></p> <p>Department of Health Services<br/>           Solid Waste Section<br/>           411 North Twenty-Fourth Street<br/>           Phoenix, Arizona 85008<br/>           (602) 255-1162</p> <p><b>CALIFORNIA</b></p> <p>California Waste Management Board<br/>           1020 Ninth Street<br/>           Suite 300<br/>           Sacramento, California 95814<br/>           (916) 322-7365</p> | <p><b>ALABAMA</b></p> <p>Alabama Department of Environmental Management<br/>           Land Division<br/>           State Office Building<br/>           Montgomery, Alabama 36104<br/>           (205) 834-1303</p>   | <p><b>FLORIDA</b></p> <p>Department of Environmental Regulation<br/>           Solid Waste Management Program<br/>           Twin Towers Office Building<br/>           2600 Blairstone Road<br/>           Tallahassee, Florida<br/>           (904) 488-0300</p>   |

Table 1  
 State Environmental Agencies for Sanitary Landfill  
 Regulation and Permit Matters (continued)

|          |   |           |   |               |  |
|----------|---|-----------|---|---------------|--|
| ILLINOIS | Environmental Protection Agency<br>Division of Land Pollution Control<br>2200 Churchhill Drive<br>Springfield, Illinois 62706<br>(217) 782-6760                               | KENTUCKY  | State Department for Natural Resources<br>and Environmental Protection<br>Division of Hazardous Materials and<br>Waste Management<br>Capital Plaza Tower<br>Frankfort, Kentucky 40601<br>(502) 564-6716 | MASSACHUSETTS | Department of Environmental Quality<br>and Engineering<br>Division of Hazardous Wastes<br>Leverett Saltonstall Building<br>100 Cambridge Street<br>Boston, Massachusetts 02202<br>(617) 727-0774 |
| INDIANA  | State Board of Health<br>Land Pollution Control Division<br>Solid Waste Management Branch<br>1330 West Michigan Street<br>Indianapolis, Indiana 46206<br>(317) 633-0176       | LOUISIANA | Department of Natural Resources<br>Solid Waste Division<br>P.O. Box 44066<br>Baton Rouge, Louisiana 70804<br>(504) 342-1216   | MICHIGAN      | Environmental Protection Bureau<br>Ground Water Quality Division<br>P.O. Box 30028<br>Lansing, Michigan 48909<br>(517) 373-2794  |
| IOWA     | Department of Water, Air, and<br>Waste Management<br>Air and Land Quality Division<br>Henry A. Wallace Building<br>900 East Grand<br>Des Moines, Iowa 50319<br>(515) 281-8853 | MAINE     | Department of Environmental Protection<br>Bureau of Land Quality<br>Division of Solid Waste Management Control<br>State House<br>Augusta, Maine 04333<br>(207) 289-2111                                 | MINNESOTA     | Pollution Control Agency<br>Solid Waste Division<br>Enforcement Section<br>1935 West County, Road B-2<br>Roseville, Minnesota 55113<br>(612) 297-2706  |
| KANSAS   | Department of Health and Environment<br>Solid Waste Management Section<br>Topeka, Kansas 66620<br>(913) 862-9360  | MARYLAND  | Department of Health and Mental Hygiene<br>Office of Environmental Programs<br>Solid Waste Management and Enforcement Program<br>201 Preston Street<br>Baltimore, Maryland 21201<br>(301) 383-2772      | MISSISSIPPI   | State Board of Health/Bureau of<br>Pollution Control<br>Division of Solid Waste Management<br>P.O. Box 10385<br>Jackson, Mississippi 39205<br>(601) 961-5171                                     |

Table 1  
 State Environmental Agencies for Sanitary Landfill  
 Regulation and Permit Matters (continued)

|   |  |  |
|---|--|--|
| <b>MISSOURI</b>   | <b>NEW HAMPSHIRE</b>   | <b>NORTH CAROLINA</b>  |
| Department of Natural Resources/<br>Division of Environmental Quality<br>Management Program<br>State Office Building<br>P.O. Box 1368<br>Jefferson City, Missouri 65102<br>(314) 751-3241 | Department of Health and Welfare<br>Bureau of Solid Waste Management<br>State Laboratory Building<br>Hazen Drive<br>Concord, New Hampshire 03301<br>(603) 271-4623 | Department of Human Resources<br>Division of Health Services<br>Solid Waste and Vector Control<br>P.O. Box 2091<br>Raleigh, North Carolina 27602<br>(919) 733-2178                                     |
| <b>MONTANA</b>  | <b>NEW JERSEY</b>  | <b>NORTH DAKOTA</b>  |
| State Department of Health<br>Solid Waste Management Bureau<br>1424 Ninth Avenue<br>Helena, Montana 59601<br>(406) 449-2821   | Department of Environmental Protection<br>Solid Waste Administration<br>32 East Hanover Street<br>Trenton, New Jersey 08625<br>(609) 292-7423                      | State Department of Health<br>Division of Water Supply and Pollution Control<br>1200 Missouri Avenue<br>Bismarck, North Dakota 58505<br>(701) 224-2375   |
| <b>NEBRASKA</b>   | <b>NEW MEXICO</b>  | <b>OHIO</b>  |
| State Environmental Control Board<br>Division of Water Waste Management<br>Permitting and Licensing<br>Box 94877<br>Lincoln, Nebraska 68509<br>(402) 471-2186                             | Department of Health and Environment<br>Bureau of Solid Waste<br>P.O. Box 968<br>Crown Building<br>Santa Fe, New Mexico 87503<br>(505) 827-5271                    | Ohio Environmental Protection Agency<br>Division of Solid and Hazardous Wastes<br>361 East Broad Street<br>Columbus, Ohio 43126<br>(614) 466-8934  |
| <b>NEVADA</b>   | <b>NEW YORK</b>  | <b>OKLAHOMA</b>  |
| Department of Conservation and<br>Natural Resources<br>Division of Environmental Protection<br>Capital Complex<br>Carson City, Nevada 89710<br>(702) 885-4670                             | Department of Environmental Conservation<br>Waste Disposal Bureau<br>50 Wolf Road<br>Albany, New York 12233<br>(518) 457-6605                                      | State Department of Health<br>Industrial and Solid Waste Service<br>Solid Waste Division<br>P.O. Box 53551<br>Northeast Tenth and Stonewall Streets<br>Oklahoma City, Oklahoma 73105<br>(405) 271-5338 |

Table 1  
 State Environmental Agencies for Sanitary Landfill  
 Regulation and Permit Matters (continued)

|  |  |  |
|--|--|--|
| <p>OREGON</p> <p>Department of Environmental Quality<br/>           Division of Solid Waste<br/>           P.O. Box 1760<br/>           Portland, Oregon 97207<br/>           (503) 229-5913</p> <p>PENNSYLVANIA</p> <p>Department of Environmental Resources<br/>           Bureau of Solid Waste Management<br/>           Pullon Building, P.O. Box 2063<br/>           Harrisburg, Pennsylvania 17120<br/>           (717) 787-7383</p> <p>RHODE ISLAND</p> <p>Department of Environmental Management<br/>           Div. of Air &amp; Hazardous Waste Materials<br/>           204 Health Building, Davis Street<br/>           Providence, Rhode Island 02908<br/>           (401) 277-2797</p> <p>SOUTH CAROLINA</p> <p>Dept. of Health &amp; Environmental Control<br/>           Solid Waste Management Division<br/>           J. Marion Simms Building<br/>           2600 Bull Street<br/>           Columbia, South Carolina 29201<br/>           (803) 758-5681</p> <p>SOUTH DAKOTA</p> <p>Department of Environmental Protection<br/>           Joe Foss Building<br/>           Pierre, South Dakota 57501<br/>           (605) 773-3329</p> | <p>TENNESSEE</p> <p>Department of Health and Environment<br/>           Bureau of Environmental Management<br/>           Division of Solid Waste Management<br/>           150 9th Avenue, North Terra Building<br/>           Nashville, Tennessee 37203<br/>           (615) 741-3424</p> <p>TEXAS</p> <p>Department of Health<br/>           Bureau of Solid Waste Management<br/>           1100 West 49th Street<br/>           Austin, Texas 78756<br/>           (512) 458-7271</p> <p>UTAH</p> <p>State Department of Health<br/>           Division of Environmental Health<br/>           Bureau of Solid Waste Management<br/>           150 West North Temple<br/>           P.O. Box 2500<br/>           Salt Lake City, Utah 84110<br/>           (801) 533-4145</p> <p>VERMONT</p> <p>Agency of Environmental Conservation<br/>           Air and Solid Waste Section<br/>           P.O. Box 489<br/>           Montpelier, Vermont 05602<br/>           (802) 828-3395</p> | <p>VIRGINIA</p> <p>State Department of Health<br/>           Division of Solid Waste<br/>           109 Governor Street<br/>           Richmond, Virginia 23219<br/>           (804) 786-5271</p> <p>WASHINGTON</p> <p>State Department of Ecology<br/>           Solid Waste Section<br/>           Olympia, Washington 98504<br/>           (206) 753-4298</p> <p>WEST VIRGINIA</p> <p>State Health Department<br/>           Division of Solid Waste<br/>           1800 Washington Street, East<br/>           Charleston, West Virginia 25305<br/>           (304) 348-2987</p> <p>WISCONSIN</p> <p>Department of Natural Resources<br/>           Bureau of Solid Waste Management<br/>           P.O. Box 7921<br/>           Madison, Wisconsin 53709<br/>           (608) 266-1327</p> <p>WYOMING</p> <p>Department of Environmental Quality<br/>           Solid Waste Program<br/>           State Office Building, West<br/>           Cheyenne, Wyoming 82001<br/>           (307) 777-7752</p> |
|--|--|--|

## Section 2: PLANNING FOR SOLID WASTE MANAGEMENT AT NAVY INSTALLATIONS

2.1 Introduction. When planning for solid waste management facilities and operations at Navy shore installations, the following steps are suggested:

- a) Determine existing and projected solid waste quantities and characteristics.
- b) Design and evaluate solid waste collection system characteristics.
- c) Evaluate opportunities for recycling and resource recovery and design, select, and implement a system(s), if cost-effective.
- d) Evaluate solid waste disposal systems and modify, design, and select the most viable system(s).

2.2 Solid Waste Characteristics. A knowledge of existing and projected solid waste quantities and characteristics is important in selecting and designing all of the other elements in the solid waste management plan.

Solid waste to be handled/disposed of at a Navy installation may come from onsite sources only, or may also come from offsite sources (e.g., a nearby city or town or other nearby Navy installation) if the installation has agreed to participate in a regional solid waste program.

Navy installations generally do not generate large quantities of solid waste. Almost 60 percent of the 39 surveyed Navy installations generated less than 60 tons (54 metric tons) per day of solid waste, and none generated more than 300 tons (272 metric tons) per day (see Stearns, Conrad and Schmidt [SCS] Engineers, Analysis of Responses to Questionnaire for Naval Shore Facilities Solid Waste Management Practices and Procedures), 73.012. Therefore, disposal systems at most Navy installations need to be capable of handling only relatively small amounts of solid waste. Further, solid waste volumes are generally too low to economically support sophisticated handling, processing, and disposal techniques available for large solid waste quantities, unless such endeavors are undertaken in conjunction with other naval installations or with local governments. A description of these techniques, including design information, is present in Section 6.

2.3 Collection and Hauling Options.

2.3.1 Direct Haul. Waste is typically hauled in the collection vehicle from the point of collection to a disposal site. This procedure is called "direct haul."

Solid waste may be collected by either Navy personnel or contractors. There may also be a combination of approaches, depending on conditions at a specific installation. A common arrangement includes contracted collection in the family housing areas, and collection by Navy personnel from the commercial and industrial sources. However, collection and haul from all areas of an installation can be accomplished by Navy personnel or by contractors.

Solid waste collection (and in fact all aspects of solid waste management) are subject to the Office of Management and Budget (OMB)-required Commercial Activities (CA) reviews. Through these reviews the feasibility of providing solid waste services through contractors are assessed. If there is a cost advantage to contracted services, preference is given to that approach. Most installations have a Commercial Activities Coordinator who can answer questions about these reviews.

2.3.2 Transfer. It may be cost-effective for a Navy installation to have its own solid waste transfer station. Transfer stations are locations where collection vehicles empty their loads into larger containers or vehicles subsequent hauling to the disposal site. Transfer stations are cost-effective where haul distances to disposal sites are relatively long. They should be considered if it is more economical to haul wastes to the disposal sites using transfer vehicles rather than by direct haul by collection vehicles. Transfer stations are usually practical only at the larger Navy installations.

2.4 Resource Recovery. Some forms of recycling are usually practiced on most Navy installations. Often materials from the industrial and commercial areas are separated at the source when there is a market for them. Most of these materials are disposed through the Defense Property Disposal Office (DPDO) on the installation. Normally, at least two grades of metal can be sold by the DPDO and in some instances there are markets for scrap wood and other materials.

Federal material recovery guidelines (40 CFR 246, Sources Separation for Materials Recovery) require the assessment of feasibility of recycling three grades of paper at Navy (and other Federal) installations. Types of paper covered are newsprint from family housing areas on installations where there are 500 or more family housing units, corrugated material from commissaries and other sources, and high-grade paper (white ledger) from office buildings in which 100 or more office workers are employed.

If the feasibility of recovering one or more of these paper grades is indicated, these programs should be established with an overall coordinator identified. The DPDO can provide information about markets for these materials.

When the DPDO sells segregated solid waste, the activity receives the proceeds.

2.5 Solid Waste Disposal. One of the first steps in developing overall Navy installation solid waste management plans is to determine the location of disposal facilities and the type of facilities to be provided. Normal solid waste is disposed of at a sanitary landfill. It is required that the Navy assure that its solid waste is disposed of in state-permitted or state-approved facilities authorized to receive the types of solid wastes generated at the installation. Such disposal may be accomplished at a Navy-owned sanitary landfill, permitted by the state in which the facility is located, or at a private or publicly owned site located on or off the Navy installation. At these facilities, it is customary for the Navy to pay a disposal fee and to have a long-term contract for the disposal of the solid wastes. These private or public sites must also be permitted to dispose of the solid wastes delivered by the Navy.

Solid wastes may also be disposed of as a part of a contracted collection arrangement. This is the situation when the installation has contracted solid waste collector who hauls the solid waste to a private or publicly owned disposal facility. In such instances, the Navy essentially relinquishes control of the solid waste when it is put into the collection vehicle. Specifications in contracts for this type of service must include the provision that the solid waste is to be disposed of in a state-permitted facility.

THIS PAGE INTENTIONALLY LEFT BLANK

## Section 3: SOLID WASTE CHARACTERISTICS

3.1 Introduction. Solid waste types and quantities generated for a Navy installation can best be determined by means of a field survey. (The field survey methodology is provided in Naval Civil Engineering Laboratory (NCE TN-1712, Phase II of the Waste Assessment Method for Navy Shore Activities Proposed Survey Method. The overall waste characterization process is contained in the M. Roberts, and K. Sevanson, Heat Recovery Application Guide.) If resources are unavailable to conduct such a survey, estimates can be made based on existing solid waste generation data for other naval installations. In the event offsite solid wastes will be accepted as a result of involvement in a regional solid waste program, it is also important to ascertain solid waste types and quantities from these source. A knowledge of the quantities and characteristics of solid wastes to be disposed of is important since these factors affect:

- a) The method of disposal to be selected (e.g. incineration, landfilling, etc.).
- b) The size and throughput capacity of the disposal facility required
- c) Environmental impacts at the disposal location (e.g., types of potential air pollutants).
- d) Viability of recycling and resource recovery (e.g., source separation, landfill gas (LFG) generation/recovery, heat recovery incineration, etc.).

3.2 Solid Waste Types. The types of solid waste that can be expected to generated at various installation sources are presented in Table 2. This information, and the information contained in Figure 1 and Tables 3 and 4 was determined as part of a solid waste generation survey sponsored by the NCEL in 1972. Solid waste composition that can be expected from an offsite municipality is presented in Table 5.

3.3 Waste Quantities. Table 3 shows reported average per capita solid waste generation rates for family housing areas for Navy installations as a whole. Information sources include the NCEL survey effort, the NAVFAC MO-213, Solid Waste Management Manual, and a 1971 survey conducted by the U.S. Air Force of 90 Air Force installations.

Figure 1 presents reported per capita solid waste generation rates by installation classification for 37 surveyed Navy installations, excluding family solid waste, but including such materials as industrial and demolition type solid waste.

Table 4 provides unit emission factors (e.g., pounds of solid waste per square foot of building space per day) for various Navy installation sources. Table 6 provides solid waste generation rates for Navy installations (excluding family housing) and for other sources. Emission factors for buildings with similar functions compare favorably between installations in most cases. For a more detailed discussion of emission factors, see SCS Engineers, Solid Waste Composition and Emission Factors Selected Naval Activities.

Table 2  
Approximate Percentage of Solid Waste by Source

| Solid Waste Component | Solid Waste Source                       |                          |                                   |   |   |                                    |                          |   |  |  |
|-----------------------|--|--------------------------|-----------------------------------|---|---|------------------------------------|--------------------------|---|--|--|
|                       | Transmission Building/Laundry Facilities | Exchanges & Commissaries | Ordnance Manufacture and Assembly | Offices, Training Rooms, Dispensaries, and Quarters | Food Service (Cafeteria, Mess, Galley, Canteen, Club) | Shops, Berthing Piers, and Wharves | Storehouses & Warehouses | Ways-Drydocks, Marine Railway, Motor Pool |  |  |
| Paper                 | 84                                       | 64                       | 74                                | 72  | 67  | 66                                 | 64                       | 47  |  |  |
| Garbage               | <1                                       | <1                       | <1                                | <1  | 5   | <1                                 | <1                       | <1  |  |  |
| Metal                 | 3  | 2                        | <1                                | 5   | 5   | 7                                  | 3                        | 8   |  |  |
| Textiles              | <1                                       | <1                       | <1                                | <1  | <1  | 5                                  | <1                       | 4   |  |  |
| Plastic               | 7  | 9                        | 4                                 | 12  | 14  | 10                                 | 11                       | 7   |  |  |
| Leather               | NO*                                      | NO                       | <1                                | NO  | NO  | <1                                 | NO                       | NO  |  |  |
| Rubber                | <1                                       | NO                       | <1                                | <1  | NO  | <1                                 | NO                       | 2   |  |  |
| Vegetation            | 3  | <1                       | <1                                | 3   | <1  | <1                                 | <1                       | NO  |  |  |
| Inerts                | 2  | <1                       | <1                                | <1  | <1  | <1                                 | 1                        | 2   |  |  |
| Wood                  | NO                                       | 4                        | 6                                 | 2   | 3   | 5                                  | 15                       | 29  |  |  |
| Glass, Ceramics       | NO                                       | <1                       | NO                                | <1  | 4   | <1                                 | <1                       | <1  |  |  |
| Miscellaneous#        | NO                                       | <1                       | 11                                | 2   | <1  | 5                                  | 2                        | <1  |  |  |

\* NO = None Observed.

# Miscellaneous includes expended fluorescent light bulbs, fibrous barrels, and carpet trimmings.

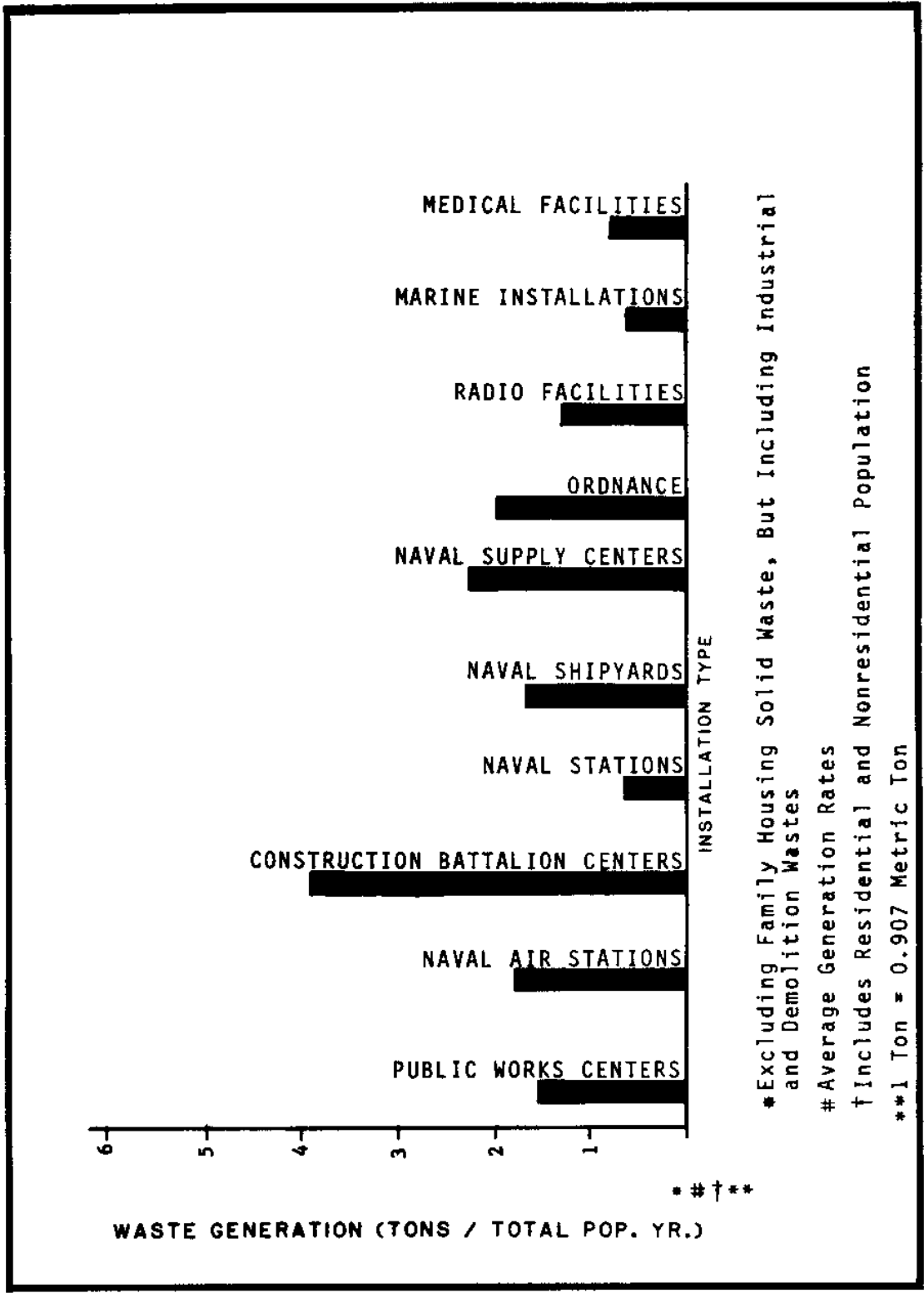

Figure 1  
 Navy Installation Solid Waste Generation Rates

Table 3  
Average Daily Solid Waste Generation Rates  
from Family Housing Areas

| Source                             | Average Waste Generation Rate (lb/person/day) [*][+] |
|------------------------------------|--|
| NCEL Survey                        | 5.81   |
| Navy Solid Waste Management Manual | 3.3  |
| Air Force survey                   | 3.94   |
| Average                            | 4.35   |

[\*] To project annual quantities, multiply daily rates by 365 days per year

[+] 11b/person/day - 0-454 kg/person/day.



Table 5  
Example Composition of Municipal  
Solid Waste[\*]

| Waste Type      | Percent of Total |
|-----------------|------------------|
| Paper           | 41.0             |
| Garbage         | 5.5              |
| Metals          | 6.0              |
| Textiles        | 2.0              |
| Plastics        | 1.5              |
| Leather, Rubber | 0.5              |
| Vegetation[#]   | 20.5             |
| Inerts[**]      | 14.0             |
| Wood            | 2.0              |
| Glass           | 7.0              |
| <b>Total</b>    | <b>100.0</b>     |

[\*] City of Los Angeles, California.

[+] Percent of wet weight.

[#] Excludes grass cuttings.

[\*\*] Includes ceramics, stones, dirt, and grass cuttings.

Table 6  
 Reported Solid Waste Generation Rates  
 from Various Sources

| UAAA<br>3<br>3<br>3 Solid Waste Source<br>3AAA<br>3 | Average Generation Rate<br>(lb/person/day) [*]<br><br>Family Housing = 5.81<br><br>Base Housing = 8.86[+]<br>Total Emissions = 9.78<br><br>Family Housing = 3.94<br>Base Facilities = 5.11[+]<br><br>Municipal Waste = 5.3[#] |
|---|---|
| 3 Navy Installations<br>3<br>3<br>3<br>3 Air Force Installations<br>3<br>3<br>3 Municipalities<br>3   |   |

AAA  
 [\*] 1 lb/person/day = 0.454 kg/person/day.

[+] Includes industrial and demolition solid waste.

[#] Does not include industrial, demolition, or agricultural waste.



## Section 4: SOLID WASTE STORAGE AND COLLECTION

4.1 Introduction. When designing a solid waste disposal facility, it is important to know the type of vehicles that will be delivering solid waste to the facility. Generally, a sanitary landfill can accommodate any type of collection vehicle; however, other disposal methods (e.g., transfer station) may be able only to accommodate certain types of vehicles due to height restrictions or other physical factors. This section addresses those aspects of solid waste collection that potentially impact upon the design of disposal facilities. A more thorough discussion of solid waste collection is contained in the NAVFAC, MO-213, Solid Waste Management Manual.

### 4.2 Solid Waste Storage.

4.2.1 Onsite Solid Waste. Solid waste at Navy installations is stored in both manually and mechanically loaded containers. Examples of storage containers used are shown in Table 7.

4.2.2 Solid Waste from Foreign Sources. The garbage portion of solid waste entering Navy ports from foreign sources must be disposed of in a U.S. port by one of the following U.S. Department of Agriculture (USDA) approved methods:

a) Cooking by steam or other heat source in a leak-proof container (dumpster) at 212 deg. F (100 deg. C) for a period of 30 minutes and disposal of residues by burying in a sanitary landfill.

b) Incinerating in an incinerator approved by the Environmental Protection Agency (EPA).

c) Grinding and flushing through a ship's collection, holding, and transfer system to a USDA-approved sewage system ashore.

4.3 Solid Waste Collection Vehicles. When selecting collection vehicles consideration shall be given to vehicle size, local weight and height limit for all roads over which the vehicle will travel, and the turning radius, unloading height to ensure overhead clearance in transfer stations, service buildings, incinerators, or other facilities.

4.3.1 Principal Types of Vehicles. Collection vehicles fall into two basic categories, waste-haul and container-haul. With the waste-haul vehicle, solid wastes are collected from individual containers by emptying the contents into the collection vehicle. The container-haul vehicle collects and transports the waste-filled container to the disposal location, empties the contents, and returns the empty container to its original location.

4.3.1.1 Waste-Haul Vehicles. The most common type of waste-haul vehicle is the compactor truck of which there are three basic types: front-loading, side-loading, and rear-loading.

a) Front-loading compactor trucks (see Figure 2) range in capacity from 20 to 52 cubic yards (15.3 to 39.8 cubic meters), and collect waste from bulk containers. The solid waste is loaded into the top front of the compactor body, and is compacted by a hydraulic ram and platen which push the solid waste against the rear of the body. An optional 5-cubic yard (3.8-cubic meter) bubble tailgate is available on these vehicles.

Table 7  
Types of Containers for Onsite Solid Waste Storage

| Type                        | Capacity Range   | Comments   |
|-----------------------------|--|--|
| <b>MECHANICALLY LOADING</b> |  |  |
| Self-loading type           | 1.5 to 15 cubic yards<br>(1.2 to 11.5 cubic meters)  | Used with compaction trucks  |
| Front-loading               | 0.5 to 10 cubic yards<br>(0.4 to 7.7 cubic meters)   | Most common of the self-loading types. Not suitable when overhead clearance is restricted.   |
| Rear- and side-loading      | 6 to 8 cubic yards<br>(4.6 to 6.1 cubic meters)  |  |
| Lugger-box type             | 2 to 20 cubic yards<br>(1.5 to 15.3 cubic meters)  | Also called hoist 'n haul or Dumpster (Dumpster is a registered trade-mark of the Dempster Division Carrier Corporation). The containers, used with hoist 'n haul vehicles, are carried to the disposal area or the transfer station, emptied, then returned to their original site.   |
| Roll-off type               | 10 to 50 cubic yards<br>(7.7 to 38.2 cubic meters), usually in increments of 4 or 6 cubic yards<br>(3.1 or 4.6 cubic meters) |  |
| Enclosed compaction type    | 15 to 55 cubic yards<br>(11.6 to 42 cubic meters)  | Special storage containers are available for use in conjunction with compaction units. They are available in various sizes and configurations suitable for loading by compactor truck, hoist-type vehicle, or tilt-frame vehicle. The containers are equipped with rollers or casters to facilitate movement in conjunction with the compactor unit. |
| <b>MANUALLY LOADED</b>      |  |  |
|                             | 55-gallon drums  | These types of containers can be conveniently loaded into any collection vehicle except a front-end loader.  |
|                             | 30- to 50-gallon galvanized steel containers<br>Cardboard boxes  |  |

5.10-22

5.10-22

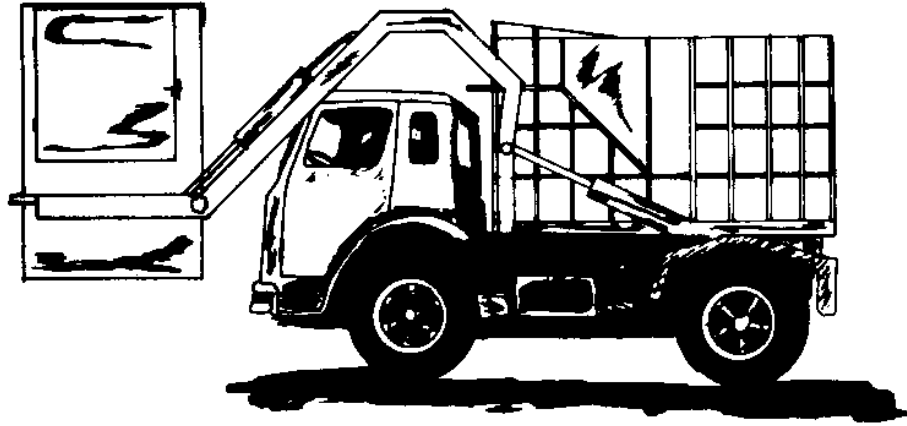

FRONT LOADING

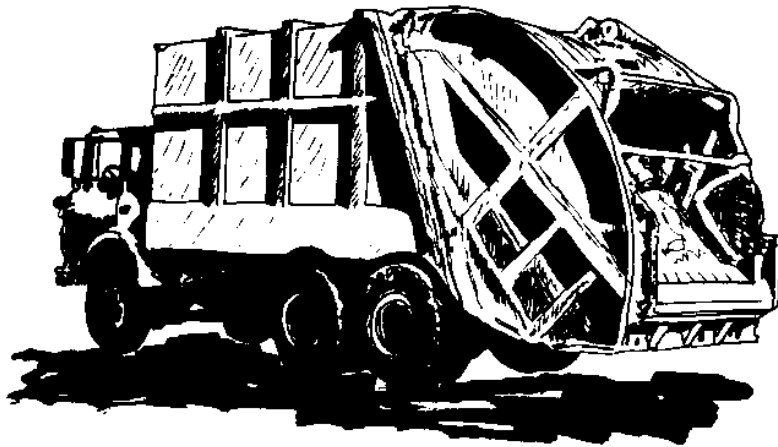

REAR LOADING

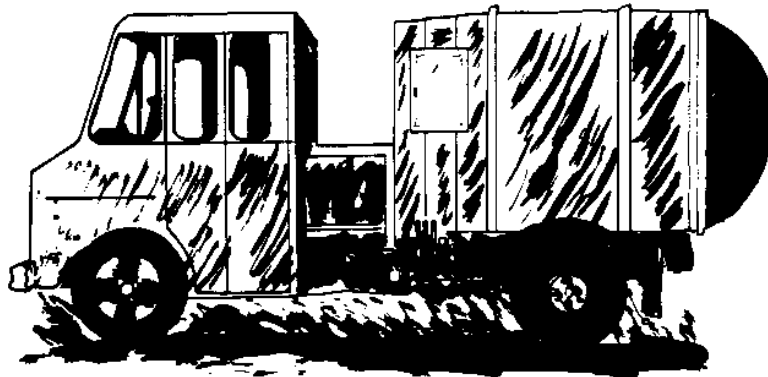

SIDE LOADING

Figure 2  
Compactor Trucks

b) Side-loading compactor trucks (Figure 2) range in capacity from 5 to 37 cubic yards (3.8 to 28.3 cubic meters). These vehicles can collect from bulk containers by mechanical lifting devices and by manual loading.

c) Rear-loading compactor trucks (Figure 2) range in capacity from 6 to 31 cubic yards (4.6 to 23.7 cubic meters). These trucks can also collect from bulk containers, but are used primarily for manual loading. The solid waste is loaded into a rear hopper and compacted by a hydraulically operated platen which pushes the waste toward the front of the body.

4.3.1.2 Container-Haul Vehicles. Two common types of container-haul vehicles are the hoist-and-haul vehicle used with lugger boxes and the tilt-frame truck used with roll-off containers and large, enclosed compaction containers. Figure 3 shows a typical hoist-and-haul vehicle and the sequence of operations of a roll-off container being loaded onto a tilt-frame truck.

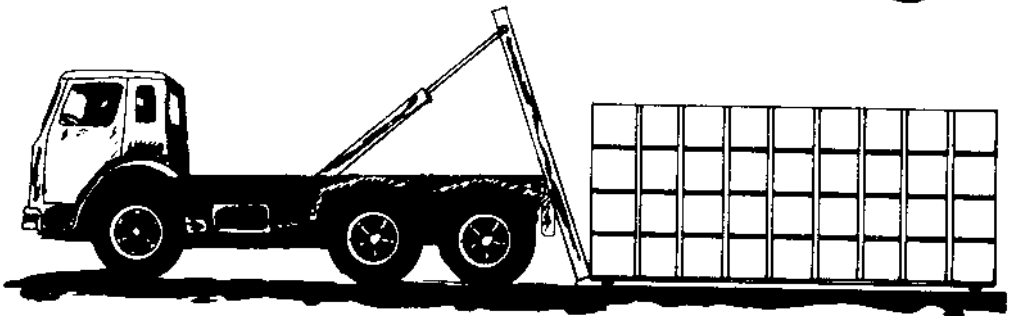
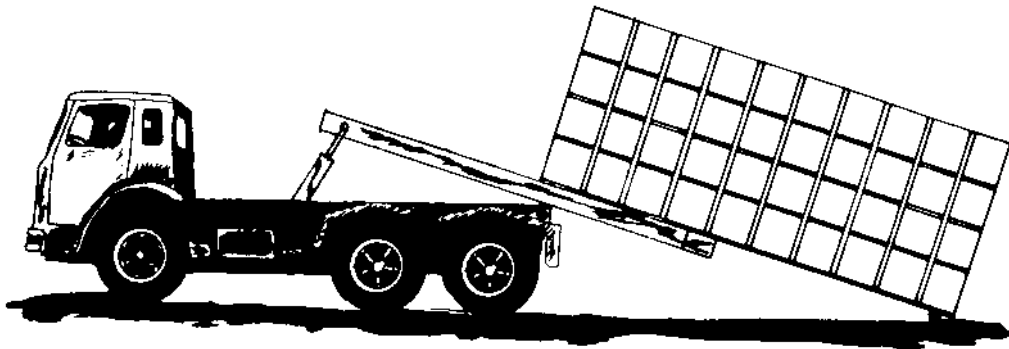

TILT FRAME TRUCK WITH ROLL-OFF CONTAINER



HOIST-AND-HAUL TRUCK WITH CONTAINER

Figure 3  
Container Haul Trucks



## Section 5. SOLID WASTE TRANSFER

5.1 Introduction. A solid waste transfer system becomes economical when the overall cost of transfer station construction and operation and waste haul to the disposal site in transfer vehicles is less than the cost of direct haul in collection vehicles.

Solid waste transfer is not required at most bases since the distance from the collection areas to the disposal site is generally short (e.g., less than 5 miles [8 kilometers]). In instances where the disposal site might be located at a remote onsite location or at an off-base regional facility, a transfer system could prove economical.

5.2 Types of Transfer Stations. There are several types of transfer station systems commonly employed, which can be categorized into noncompaction and compaction systems.

5.2.1 Noncompaction Systems. The direct dump to container system is the most basic and simple form of transfer system. This system is employed where small volumes (100 cubic yards [76 cubic meters] or less) of solid wastes are handled. Container volumes range from about 15 to 55 cubic yards (12 to 42 cubic meters). Full containers are replaced with empty ones, and the full container is transported to the disposal site by tilt-frame truck. This type of system is advantageous because of low capital costs and simple loading methods. However, because of the low solid waste densities (about 200 pounds per cubic yard [112 kilograms per cubic meter]) obtained, special containers may be required to handle incoming waste during peak periods. Also there are potential hazards associated with this method, including leachate generation due to rainfall into the open box and the possibility of someone falling into the container while unloading solid waste.

With the dump into trailer method, solid waste is dumped from an elevated area into trailers instead of drop boxes. It is more commonly used than the drop box system. Trailers are available to handle up to and even over 130 cubic yards (100 cubic meters). Open-top trailers are less expensive initially and require less maintenance than the alternative compactor trailer types. Disadvantages of trailer systems are the same as for the drop box systems except haul costs are less due to the larger load. Once the solid waste is in the trailer, it is generally leveled and further compacted by a backhoe or similar tamping device.

At the disposal site, various methods are used to unload the trailers with the most efficient being the live bottom trailer. The floor of these trailers consists basically of a conveyor or other active type floor system which, when activated, automatically unloads the trailer.

There are several methods commonly employed to feed waste into transfer trailers, including the methods described below.

5.2.1.1 Direct Dump. With this method, solid waste is dumped directly into the trailer from the collection vehicle from an elevated ramped area (see Figure 4). This method is suitable for solid waste quantities up to 100 cubic yards (76 cubic meters) per day.

5.2.1.2 Dump to Storage Pit. For this system, solid waste collection vehicles dump directly into a storage pit where the waste materials are crushed by crawler tractors and then pushed over the ledge of the storage area into the trailer. This method is generally employed where solid waste quantities delivered exceed 500 cubic yards (380 cubic meters) per day.

5.2.1.3 Dump to Tipping Floor. This method is similar to the storage pit method, except solid wastes are dumped onto a tipping floor rather than a storage pit, crushed by crawler tractors, and pushed into the trailer (see Figure 5). This method is used effectively when solid waste delivery rates range from 100 to 500 cubic yards (76 to 380 cubic meters) per day.

5.2.2 Compaction Systems. These systems are generally employed only at locations where solid waste delivery rates exceed 500 cubic yards (380 cubic meters) per day. In a hydraulic compaction system, a transfer trailer is backed into position and locked to a stationary compactor firmly anchored to a concrete foundation. The compactors used are large, heavy-duty units capable of handling most materials and producing the waste densities necessary to obtain maximum legal payloads. During operation, solid waste is loaded to the compactor from a hopper and the hydraulically powered reciprocating ram of the compactor forces the refuse horizontally through the door in the rear of the transfer trailer. At the disposal site, the entire rear section of the transfer trailer is opened and the waste pushed out by an ejection ram. Because this system requires that the transfer trailer be attached to the compactor, any hydraulic compaction system prohibits the use of drive-through arrangements.

There are several methods of feeding waste to the compactor hopper including:

- a) Direct dump into the hopper.
- b) Dump into a hydraulic push-pit equipped with a hydraulically activated ram which automatically feeds waste into the hopper.
- c) Dump into a storage pit or tipping floor where waste is crushed and pushed into the hopper by a wheel loader or crawler tractor.
- d) Dump into an inclined conveyor which automatically feeds waste into the hopper.

Table 8 presents a summary of transfer station systems available for use at Navy installations, including advantages and disadvantages of each system.

5.3 Environmental Impacts. The environmental impacts associated with the transfer and haul of unprocessed solid waste include:

5.3.1 Noise. Sources of noise at the transfer station include the operation of collection and transfer vehicles, and any loading and compacting/tamping equipment.

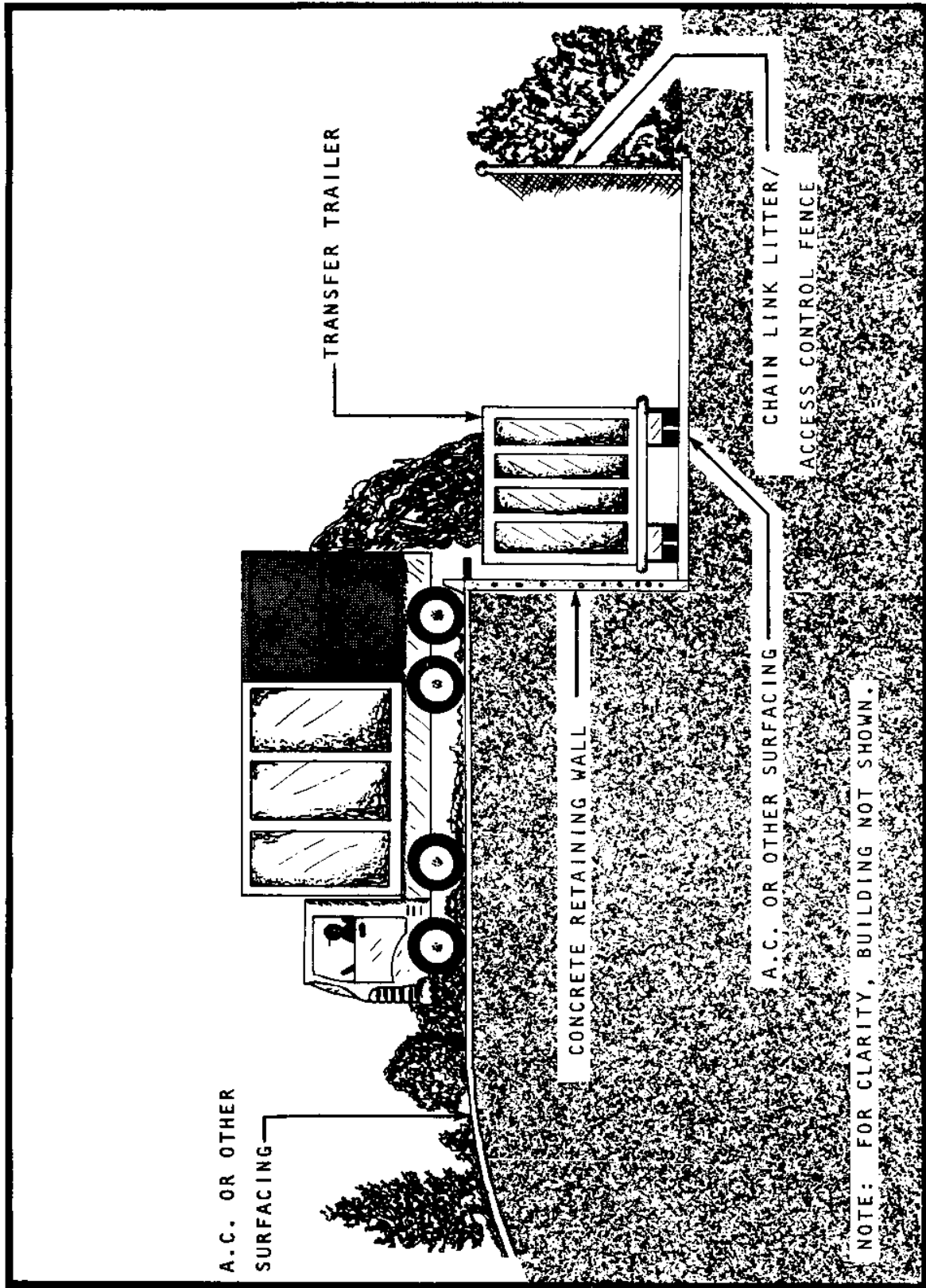

Figure 4  
Direct Dump to Trailer Transfer Station

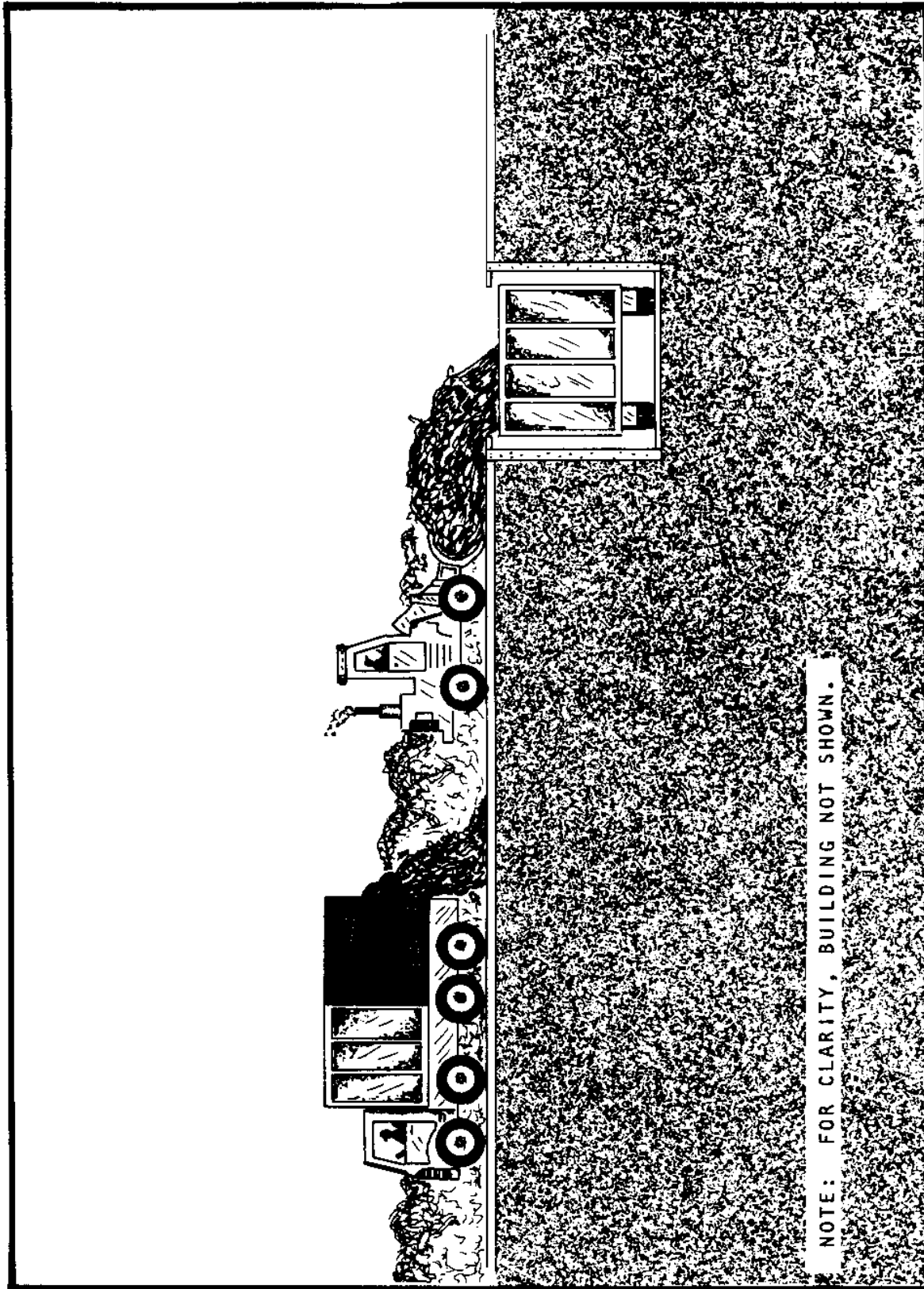

Figure 5  
Direct Dumping to Tipping Floor Transfer Station

Table 8  
Transfer Station Summary Table

| Type                                | Volume of Solid Waste Most Economically Handled          | Generally Applicable at Navy Installations | Advantages  | Disadvantages  |
|-------------------------------------|--|--|---|--|
| <b>NONCOMPACTION SYSTEM</b>         |  |  |   |  |
| Direct Dump to Container            | Up to 100 cubic yards (76 cubic meters)/day              | Yes  | Low capital costs, simple unloading, low operation and maintenance costs.   | Low solid waste densities, potential leachate due to rainfall in open box.   |
| Dump into Trailer                   |  |  |   |  |
| Direct Dump                         | Up to 100 cubic yards (76 cubic meters)/day              | Yes  | Same as for direct dump to container except costs are less due to larger payloads.  | Same as for direct dump to container.  |
| Dump to Storage Pit                 | Over 500 cubic yards (380 cubic meters)/day              | No   | Can efficiently handle large volumes of solid waste; simple unloading, haul costs low due to large payloads.              | Operation maintenance costs higher than above systems; potential for person falling into pit.  |
| Dump to Tipping Floor               | From 100 to 500 cubic yards (76 to 380 cubic meters)/day | Yes  | Same as dump to storage pit except capital costs are less.  | Same as dump to storage pit except there is no potential for falling into pit.   |
| <b>COMPACTION SYSTEM</b>            |  |  |   |  |
| Dump into Hydraulic Compaction Unit | Over 500 cubic yards (380 cubic meters)/day              | No   | Haul costs low due to compacted payloads, little or no exposure of waste to atmosphere. Can handle large volume of waste. | If compactor fails, no way to load trailers, high capital cost, someone could fall into compaction unit, no way to have drive-thru arrangements. |

5.3.2 Air Quality. Air quality impacts at the transfer station include idling of collection vehicles during dumping operations, exhaust from operation of front-end loaders or crawler tractors, and dust generated by the unloading of collection vehicles and haul vehicles. Site users and workers are exposed to dust especially when stations are enclosed; however an enclosed station decreases the impacts on the surrounding community.

The impact on air quality due to waste transfer is measurable; however it is less than if waste is hauled directly to the disposal site via collection vehicles.

5.3.3 Odors. Objectionable odors can occur when mixed solid waste containing organic matter accumulates in an environment conducive to putrefaction. To minimize odors, the waste receiving area at the transfer station should be designed and staffed to handle peak day loads with adequate time provided for a thorough daily cleanup.

5.3.4 Traffic Congestion. Traffic to and from the transfer station may cause congestion on nearby streets and intersections. Also, haul operations can cause significant congestion thereby slowing station operations. Scheduling of collection and transfer truck trips to avoid peak traffic hours can reduce this problem.

5.3.5 Litter. The site should be fenced to contain any blowing litter, a daily litter cleanup procedure should be included in the operation plan. All solid waste transferred to and unloaded at the site should be covered to minimize the problem. Haul trailers do not generally contribute to littering because the solid waste is usually compacted or completely contained inside the truck.

5.3.6. Water Contamination. Water pollution impacts at the transfer station stemming from rainfall into the transfer containers or washdown of the transfer station area and of the transport vehicles can be mitigated by collecting and channelling runoff waters to a sewer system, or by collecting and treating the runoff prior to disposal.

5.4 Transfer Station Siting. Finding an optimal transfer station site can be accomplished in the following manner:

- a) Determine the type and size of site required for initial transfer station operations and for possible future expansion of transfer station operations or construction of resource recovery facilities.
- b) Identify potential areas where a site of this size could be located.
- c) Evaluate potential sites using the following criteria:
  - 1) Collection and transfer vehicle access.
  - 2) Availability of proposed site for use as a transfer station.
  - 3) Proposed future surrounding land use.
  - 4) Existing facilities adjacent to proposed site.
  - 5) Environmental impacts (e.g., visual, odors, etc.).
  - 6) Foundation conditions.
  - 7) Central to existing and proposed future collection areas.
  - 8) Proximity to existing or projected future disposal

location.

A numerical rating system, as illustrated in Table 9, can help rank the sites in order of preference. Note that a rating system can provide reasonable approximation of the best site location, but engineering judgement will still be essential in deciding on the final site location.

5.5 Transfer Station Costs. Costs to be considered are as follows:

a) Capital Costs.

- 1) Design engineering and environmental impact statement (EIS) preparation.
- 2) Legal costs (permitting, etc.).
- 3) Land acquisition.
- 4) Site improvement overhead (SIOH).
- 5) Site preparation.
- 6) Concrete structures, foundations, and buildings.
- 7) Security system.
- 8) Landscaping.
- 9) Transfer bins, tractors, and trailers.
- 10) Wheel or track loader.
- 11) Equipment for leveling and tamping solid waste in transfer trailers.

b) Annual Costs.

- 1) Transfer bins, trailers, and tractors
  - (a) Operations and Maintenance (O & M).
  - (b) Taxes, licenses, and insurance.
- 2) Labor.
- 3) Transfer station O & M.
- 4) Building amortization (as applicable).
- 5) Transfer station equipment O & M (as applicable).

Once these costs are developed, a comparison with direct haul versus transfer vehicle can be made and the most viable system selected. Figure presents an illustration of direct haul versus transfer haul cost comparison curves.

Table 9  
Example Transfer Station  
Site Rating Evaluation

| Evaluation Criteria                       | Site No.  |           |           |           |           |
|---|-----------|-----------|-----------|-----------|-----------|
|   | 1         | 2         | 3         | 4         | 5         |
| Central to Collection Area[+]             | 8[*]      | 4         | 8         | 6         | 10        |
| Proximity to Disposal Site[+]             | 5         | 6         | 7         | 8         | 3         |
| Collection and Transfer Vehicle Access[+] | 8         | 10        | 6         | 4         | 8         |
| Existing and Future Land Use              | 3         | 2         | 4         | 2         | 5         |
| Land Area Available                       | 4         | 2         | 4         | 3         | 3         |
| Availability of Site                      | 3         | 2         | 3         | 5         | 3         |
| Environmental Impacts                     | 3         | 4         | 2         | 2         | 2         |
| Foundation Conditions[+]                  | 6<br>##   | 6<br>##   | 5<br>##   | 5<br>##   | 7<br>##   |
| <b>Total Score</b>                        | <b>40</b> | <b>36</b> | <b>39</b> | <b>35</b> | <b>41</b> |

[\*] Rating system scoring is based on a scale of 1 to 5, with 5 meaning that the site best meets the criterion. Criteria with + are double weighted to indicate relative importance.

[#] Most desirable site, based on rating system.

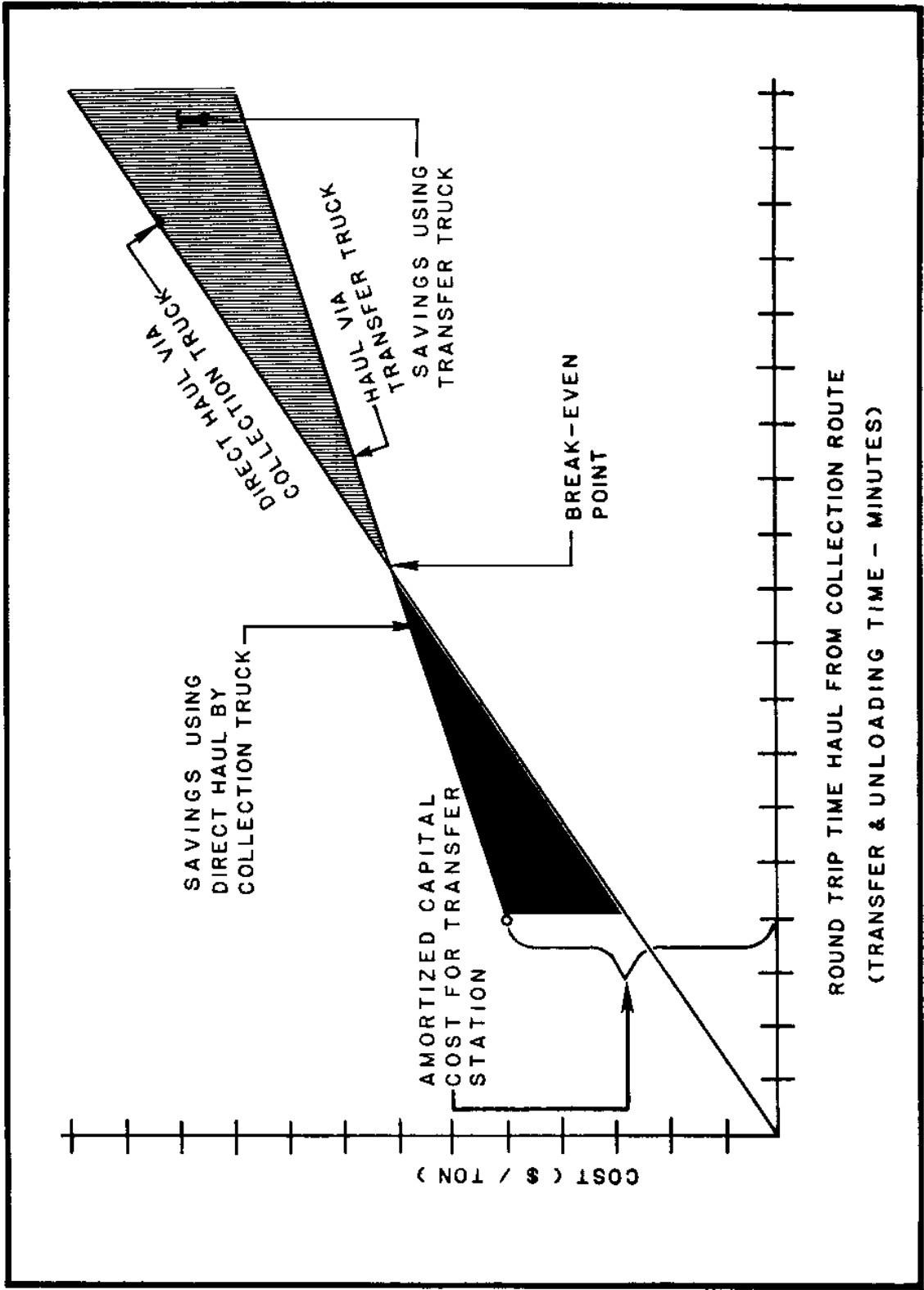

Figure 6  
 Illustration of Direct Haul Versus Transfer Haul  
 Cost Comparison Curves

5.10-35

5. 10-35



## Section 6: SOLID WASTE PROCESSING AND VOLUME REDUCTION CONVERSION

6.1 Solid Waste Processing Operations. Solid waste may be processed manually, mechanically, or both for the purpose of separating and recover materials from it, and to reduce the amount of material requiring disposal at a sanitary landfill. Commonly used waste processing operations and their benefits are summarized in Table 10.

The configuration of a mechanical solid waste processing system is selected to achieve site-specific product specifications. A schematic representation of a processing configuration is shown in Figure 7 to familiarize the reader with typical system variations employed to recover various solid waste-derived materials. As illustrated in the figure, various degrees of processing and of material recovery are potentially possible. In general, the greater the degree of processing, the greater quality (i.e., lack of contamination) of the recovered materials, and the higher the cost of equipment and operations.

The area required for a solid waste processing plant depends on a number of factors, including the mass throughput rate, the degree of processing, and storage requirements. As an example, the area of a building to house the system schematically shown in Figure 7 would be about one fourth acre (1000 square meters) for a plant with a throughput capacity of 100 tons (metric tons) per day. Approximately one fifth of that area would be devoted to solid waste receiving and storage.

Diagrams of several of the unit processes described in this section are shown in Figures 8 through 10.

6.1.1 Source Separation/Recycling. Source separation is the manual segregation of solid waste into a disposable component, and a recyclable component or components at the point of solid waste generation. The items most commonly recycled through source separation are corrugated fiber, newspaper, glass, steel cans, and aluminum beverage containers. In the case of residential solid waste, the segregated recyclable items are collected from individual households using collection vehicles (i.e., curbside collection); alternatively, recyclable items are brought by individuals to centralized recycling centers. Recycling centers may or may not offer payment for materials taken to the center.

The quantities of materials and the number of segregated components are generally the governing factors in the selection of the type of equipment used in curbside collection programs. The type of equipment used in curbside collection programs varies from commercially available collection vehicles to specially designed vehicles and container systems.

Materials collected at the curbside are generally taken to a central location for processing and storage. At the centralized recycling center separated items often require some processing (e.g., shredding and baling) to facilitate their transportation and to meet secondary material specifications.

Table 10  
Solid Waste Processing Operations

| Operation           | Typical Benefits  |
|---------------------|---|
| Source Separation   | Reduces mass of waste requiring landfilling through manual separation of aluminum cans, steel cans, glass, newspaper, and corrugated fiber prior to conventional commercial collection. |
| Size Reduction      | Improves compatibility of refuse with other processing equipment; reduces need for landfill cover material; improves marketability of recovered secondary materials.                    |
| Air Classification  | Concentrates combustible material in the light fraction; concentrates metals and glass in the heavy fraction.   |
| Screening           | Improves the quality of refuse-derived fuel (RDF) and compost; serves to concentrate cardboard and can stock.   |
| Magnetic Separation | Yields marketable ferrous scrap product; improves quality of RDF.   |
| Densification       | Facilitates transportation and storage of RDF; necessary for stoker firing of RDF.  |
| Baling              | Facilitates handling, transport, and storage of refuse or recovered materials; increases density of waste to be landfilled.   |

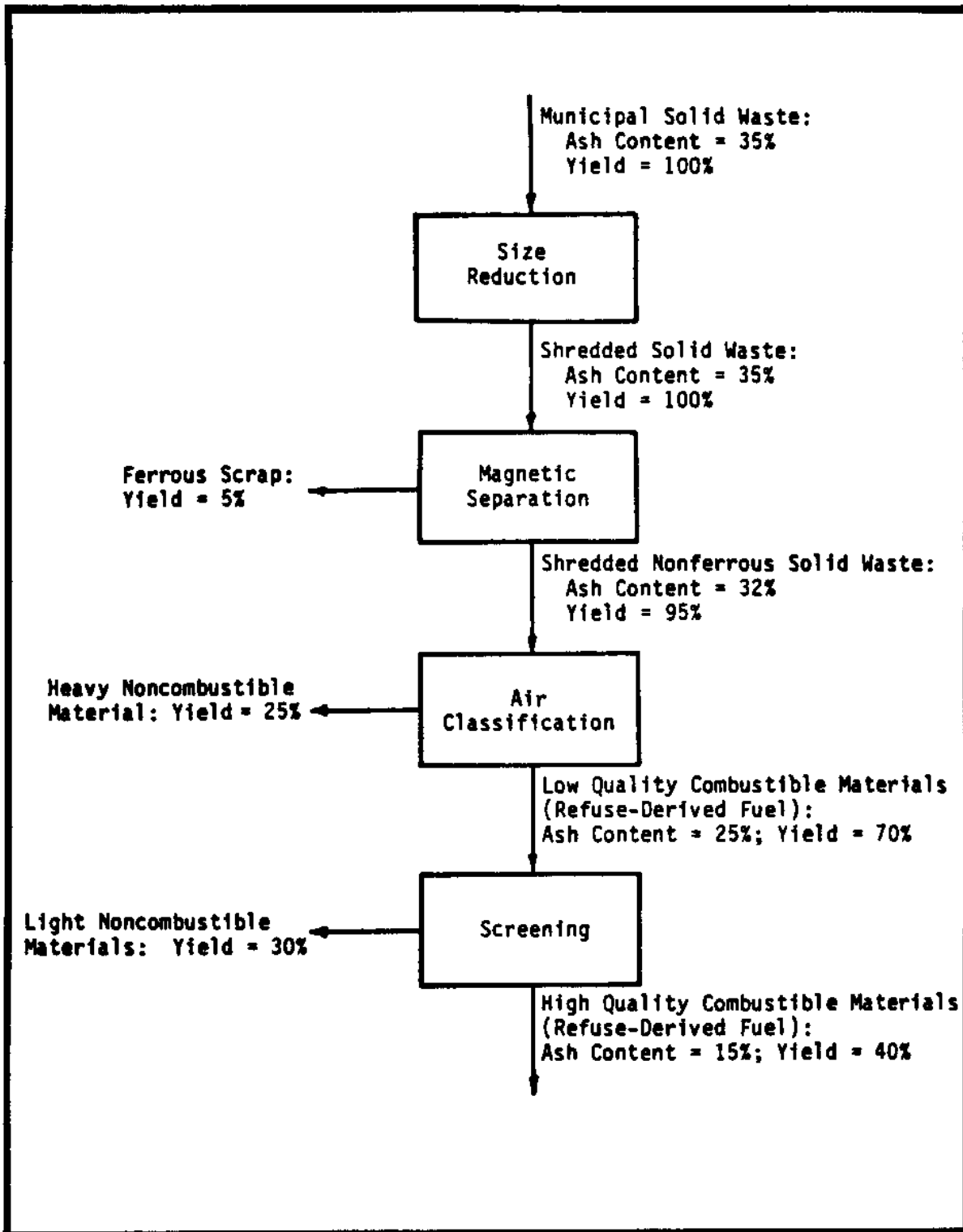

**Figure 7**  
**Example of System Configuration for**  
**Recovering Ferrous Scrap and Refuse-Derived**  
**Fuel from Municipal Solid Waste**

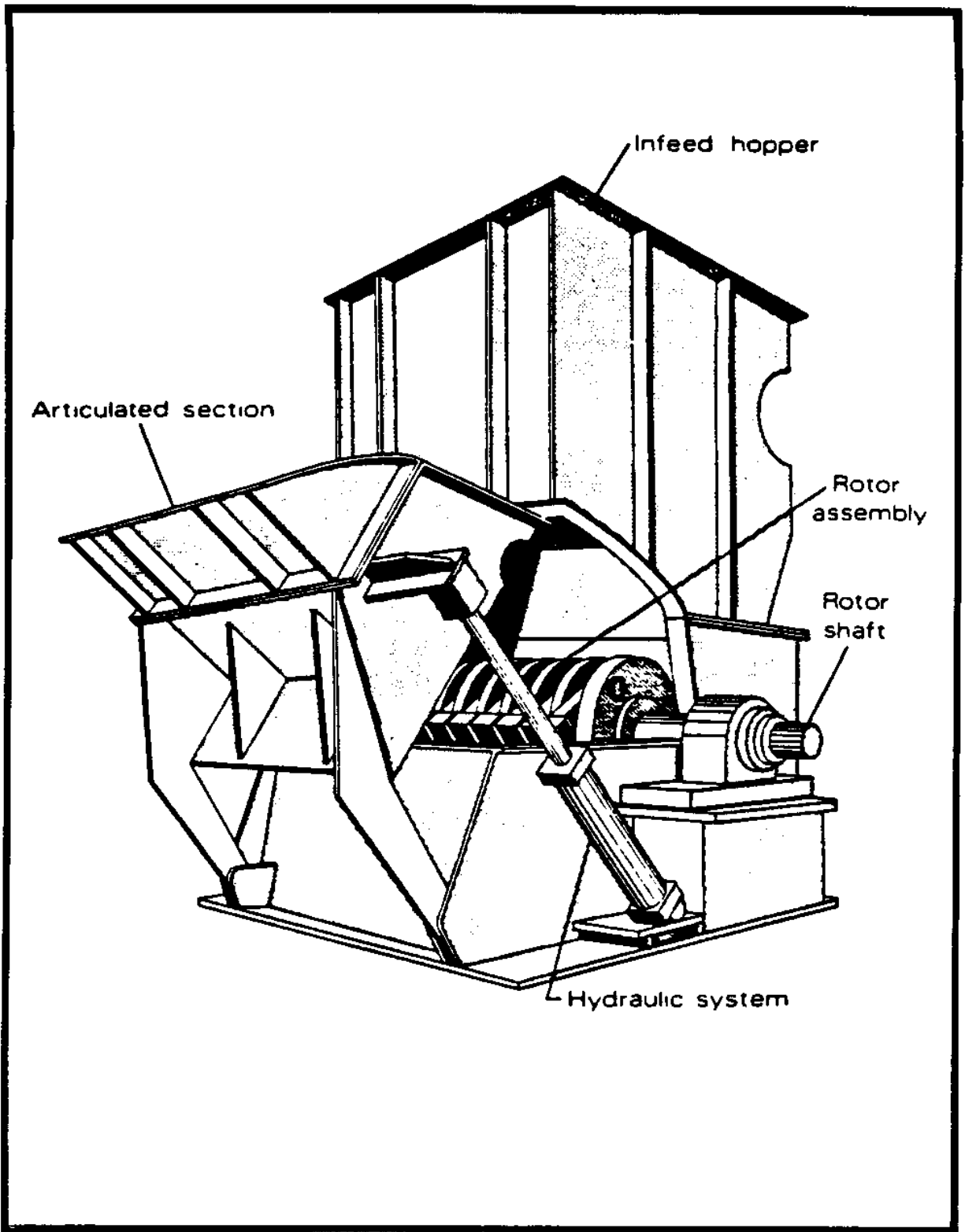

Figure 8  
Horizontal Hammermill

5.10-40

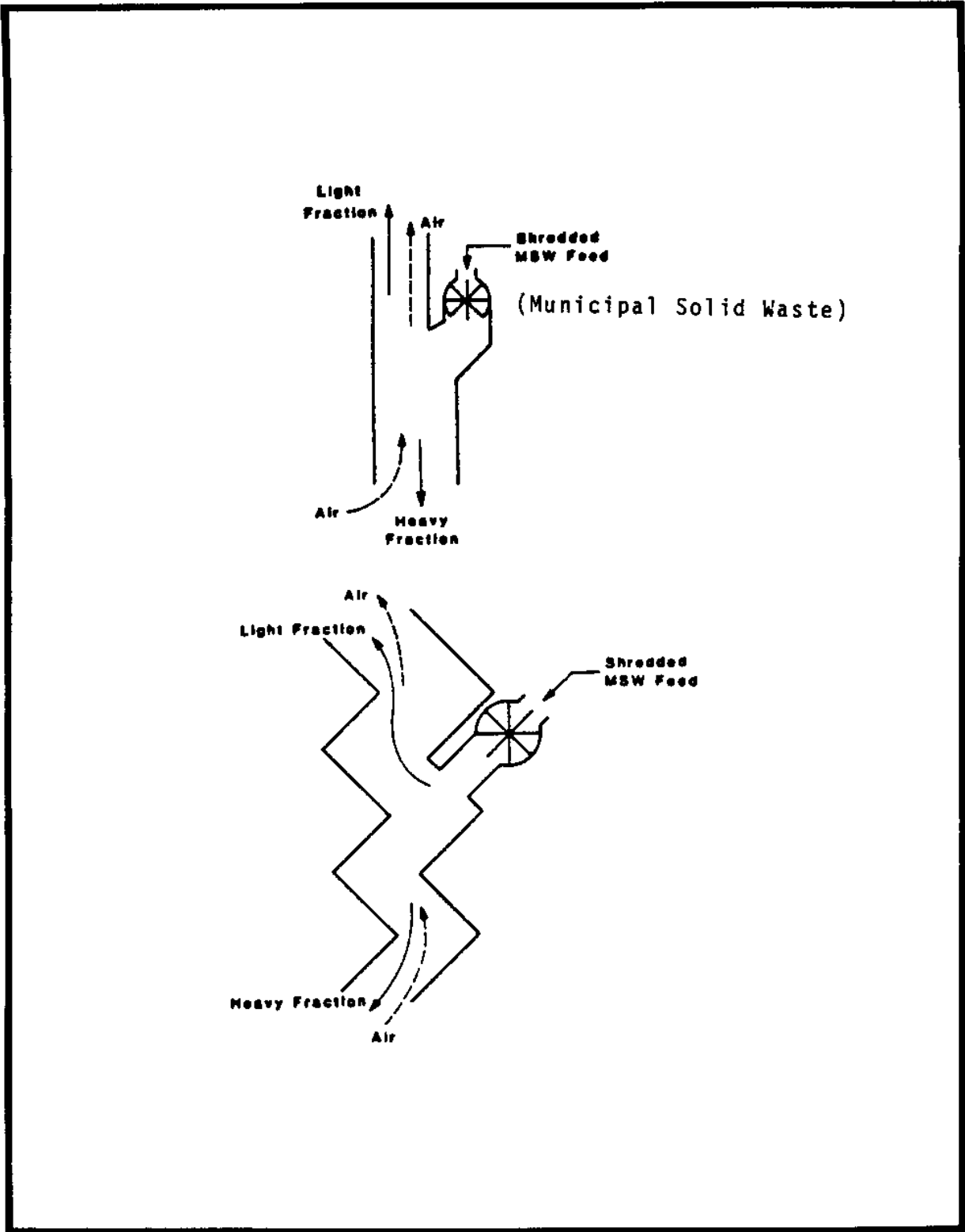
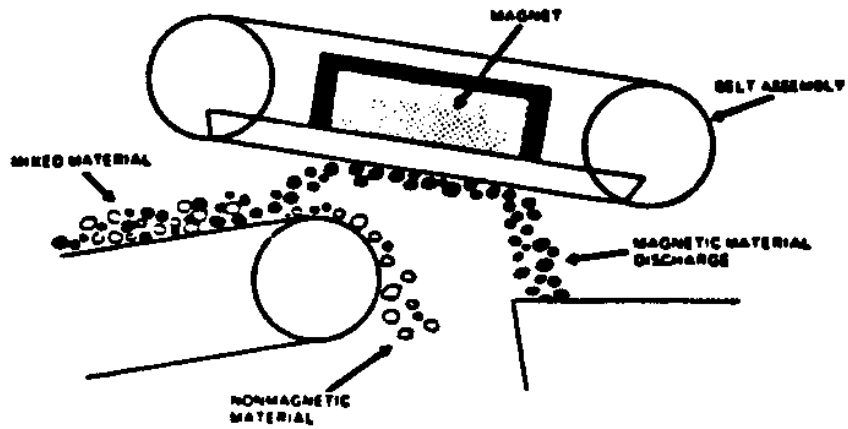

Figure 9  
Types of Air Classifiers



Overhead Belt Magnet

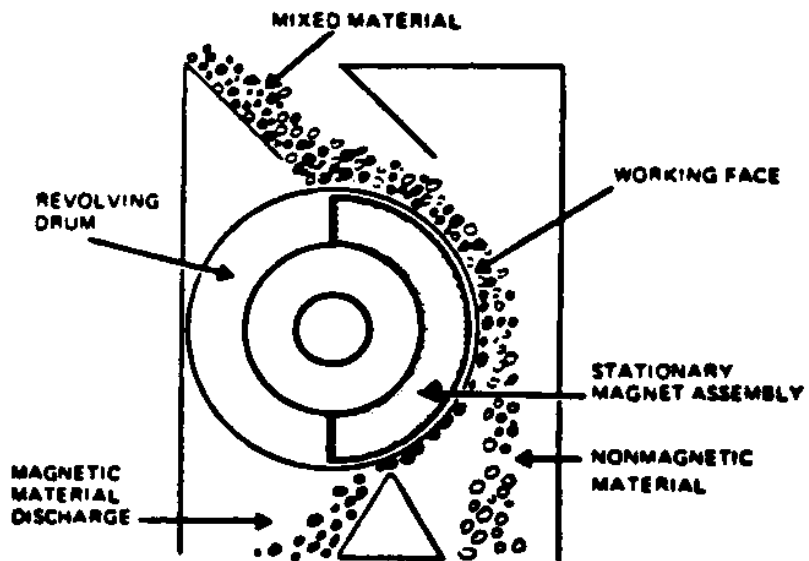

Figure 10  
Types of Magnetic Separation Systems

Source separation may also be instituted at commercial and institutional establishments. Generally, containers for each recyclable component are located at each work station, at a central collection area, both. The removal of stored material occurs at regular intervals depending on the type of component, the rate of recovery, and the material sales arrangements.

6.1.2 Size Reduction. Size reduction is a mechanical process whereby materials are reduced in size through breaking and tearing as a consequence of the action of rotating elements. The materials are held within a size reduction device until their particle sizes are less than those of the discharge opening(s) of the device. The top size of the size-reduced product and its size distribution are governed by a number of factors, including the configuration of the rotating elements, geometry of the discharge openings, the characteristics of the feedstock, and the feed rate. Hammermills are the most commonly employed pieces of size reduction equipment for processing refuse. Hammermills utilize high-speed, rotating hammers to achieve size reduction. Size reduction is often the first operation in a refuse processing system because it renders the waste more compatible with other processing equipment, and it liberates and exposes materials so that they can be separated downstream by other processing equipment.

Size reduction is also employed in some instances in landfilling applications where allowed by regulations, inasmuch as landfills composed of shredded waste (termed "shred fills") require less cover soil than the landfilling of unprocessed solid waste (i.e., direct from the collection vehicle).

6.1.3 Air Classification. Air classification is a process employing principles of aerodynamics to segregate materials into a "light fraction" and a "heavy fraction." Particles with a high drag-to-weight ratio are entrained in a stream of air and compose the light fraction. In the case of air classification of shredded solid waste, the light fraction is typically composed of paper, plastic, and very small particles of all material categories, and is termed a combustible fraction. Air-classified light fraction is one form of refuse-derived fuel (RDF). The particles not entrained in the air stream compose the heavy fraction. Metals, rock, leather, rubber, dense plastics, glass, and wet bulky materials such as garbage are concentrated in the air-classified heavy fraction. The concentration of recoverable materials in the heavy fraction (such as metal and glass) facilitates their recovery by subsequent processing equipment.

Air classification is also employed to remove contamination (e.g., paint and plastic) from highly concentrated fractions, such as ferrous scrap recovered using a magnetic separator.

6.1.4 Screening. Screening is a process whereby particles are segregated according to size in two dimensions. The desired segregation of particle sizes is effected by exposing the particles to a surface composed of openings of the appropriate size. The "oversized fraction" from a screen operation refers to particles that are either too large to penetrate the openings or are not exposed to openings due to interference. The "undersized fraction" refers to the materials that pass through the openings.

Three types of screens are used in the processing of refuse: trammel screens, flatbed screens, and disc screens. The first two types of screens employ rotating and vibrating actions, respectively, to cause material to repeatedly fall onto the screening surface (composed of wire mesh or perforated plate), and to progress along the screen. In the case of disc screens, a series of rotating discs move the material horizontally along the screen surface. Material falling through a disc screen is governed by the dimensions of the spaces between the discs and between the shafts on which the discs are mounted.

Screen openings generally are either round or square. The size of the opening varies from 0.5 inches (13 millimeters) to 4 inches (102 millimeters), depending on the location of the units within the overall processing plant.

Screening is typically used in solid waste processing systems to improve the quality of the stream fraction destined for use as a refuse-derived fuel. Quality improvement is accomplished by removing the finely sized particles. The finely sized particles are predominately high in ash content and in moisture content, and low in heating value. The average particle size of RDF can range from 1 inch (25 millimeters) to 4 inches (102 millimeters).

Screens can be used for several other purposes in solid waste processing such as scalping large pieces of cardboard from the raw solid waste stream, concentrating aluminum cans, and controlling the size of particles destined for incineration. The concentration of cardboard and cans is generally done with "pre-trommel screens," that is, screens employed prior to size reduction of raw solid wastes.

6.1.5 Magnetic Separation. Magnetic separation is a process whereby ferromagnetic materials are removed from a mixture of magnetic and nonmagnetic materials through the application of a magnetic field. Three types of magnetic separators are used in refuse processing systems, namely the overhead belt magnet, the magnetic head pulley, and the drum magnet. Each type of separator relies upon magnetic attraction and ballistics to effect the recovery of the magnetic ferrous materials. The purity of the recovered ferromagnetic material is a function of the extent of upstream processing, of the throughput, and of the strength and spatial arrangement of the magnetic separation system.

6.1.6 Densification. As it applies to refuse-derived fuel, densification consists of the formation of high density unit particles through the application of high pressure to a confined mass of properly prepared combustible fraction of solid waste. The unit particles can take the form of pellets, cubes, or briquettes and typically have linear dimensions on the order of 0.8 to 1.6 inches (20 to 40 millimeters). The rotary die pellet mill is the most commonly used device for the densification of refuse-derived fuel. In a typical pellet mill application, air-classified light fraction (or screened air-classified light fraction) is forced against the inner face of a cylindrical die whereby the material is extruded through radially oriented holes in the die. The feedstock is compressed as a result of friction between the material and the walls of the cylindrical die openings. Densified refuse-derived-fuel (termed "d-RDF") has a bulk density that is about 5 to 10 times that of the RDF feedstock, and is thus more easily transported and stored than fluff (i.e., loose) RDF. Also, combustion of d-RDF is the preferable form of RDF for some types of boilers.

6.1.7 Baling. A baler consists of a hydraulic ram that compresses solid waste into a confined space. The resulting bales can be tied either manually or automatically. Balers may be either batch fed or continuous fed, the later being more suitable for high production rates. Baling facilitates the handling, transport, and storage of refuse or of individually separated components of refuse. In some areas of the countr solid waste is baled and landfilled. Paper is typically compressed to a bulk density of 500 to 800 pounds per cubic yard (300 to 500 kilograms pe cubic meter) as a consequence of baling. Baled tin can stock reaches densities exceeding 2500 pounds per cubic yard (1500 kilograms per cubic meter).

## 6.2 Solid Waste Conversion Technologies.

6.2.1. Incineration/Energy Recovery. Solid waste may be burned in an incinerator to reduce the volume of waste requiring landfill disposal. Incineration of waste may be accompanied by energy recovery typically in form of hot water, steam, electric power, or a combination thereof. Waterwall incinerators and two-chambered modular incinerators are the prevalent technologies used for recovering heat energy from combustion of solid waste. For cases where the quantity of solid waste is less than 20 tons (180 metric tons) per day, factory-built, modular incineration syste appear to be the preferred choice of technology at the present time. In case of water-wall incinerators, water is circulated through pipes in the wall of the combustion chamber to produce saturated (or superheated) stea or hot water. Superheated steam may be used for the production of electrical energy, industrial process heat, space heating, air conditioni and hotel service dockside. Generally, in the case of modular incinerato only saturated steam or hot water is produced. The thermal efficiency of heat recovery incinerators (HRI) with capacities less than 200 tons (180 metric tons) per day typically is in the range of 50 to 70 percent.

The feedstock for a solid waste incineration system may be unprocesse or processed solid waste. The choice is primarily a matter of solid wast management objectives, degree of desired secondary material recovery, environmental considerations (e.g., ash disposal), and overall project economics.

In terms of land requirements, a 100 ton (90 metric ton) per day incineration plant operating 24 hours per day (with no preprocessing of t waste) Would occupy about 1/2 acre (2000 square meters), about half of wh would be used for tipping and storage of refuse. An illustration of a modular beat recovery incineration system is shown in Figure 11.

The Naval Civil Engineering Laboratory (NCEL), Port Hueneme, Californ has reviewed existing heat recovery incinerators (HRIS). In the matter o selecting and designing HRIS, reference is made to a NCEL publication on HRIS: CR84.014, Recommended Design of 50 TPD Facility. Also see heat recovery application guidance in MIL-HDBK-1003/2, Incinerators.

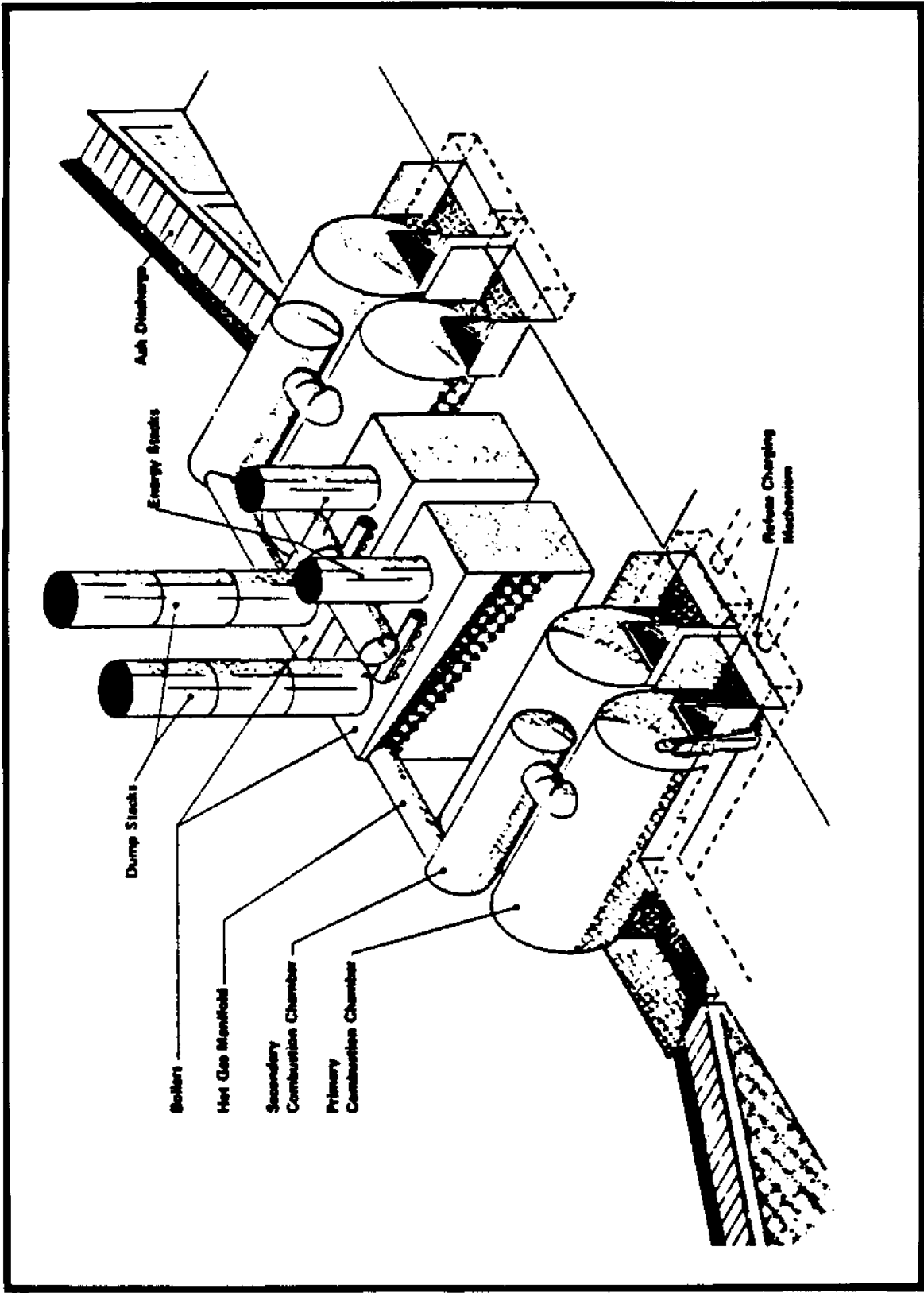

Figure 11  
Modular Heat Recovery Incineration System

6.2.2 Gasi fication. This technology is not practical for usage at this time. Do not use.

6.2.3 Composting. In the engineering sense, composting is the biostabilization of organic matter under controlled conditions. The orga matter in solid waste may be converted to a soil-like product through the composting process. The purpose of composting solid waste, or fractions derived therefrom, is to produce a usable product and to thereby reduce t mass of material requiring landfill disposal.

There are two basic types of composting processes. In anaerobic composting, decomposition and biostabilization of the organic material oc in the absence of molecular oxygen. On the other hand, in aerobic composting, decomposition and biostabilization of the material occur in a oxygen-rich environment. Aerobic composting has the disadvantage of requiring regular aeration of all parts of the composting mass. However, aerobic composting is generally considered preferable to anaerobic composting because biostabilization is achieved at a faster rate, less objectionable odors are produced, and the associated heat generation produces temperatures above the thermal death point of pathogens general l associated with solid waste (and sewage sludge, which is often added).

Generally, solid waste is processed before composting in order to rem most of the inorganic components. Drying, screening, and size reduction the composted material may be required after completion of the composting phase in order to meet user requirements. The extent of preprocessing an postprocessing depends on the composition of the solid waste feedstock, o the intended use of the produce, and on the economics of the project.

Three factors that generally affect the rate of aerobic composting, a the rate of aeration, the moisture content of the feedstock, and the rati of available carbon to nitrogen in the feedstock. The second and third factors can be beneficially influenced by the addition of sewage sludge t the solid waste fraction. At the same time, the utilization of solid was in the composting of sludge is beneficial in terms of providing bulk and porosity to the mixture, of lowering the moisture content, and of increas the carbon/nitrogen ratio.

Aeration of the composting mass is affected by regular turning, mixin and agitation of the mass or by forced aeration of the mass using an arra of perforated ducts embedded in the compost piles and blowers to supply t air. Mechanical mixing or forced aeration may be used as the aeration technique in open systems in which windrows (i.e., elongated piles of compost) are placed on the ground; or these processes may also be used in closed or semi-closed systems in which bins, silos, or other enclosures contain the composting mass.

For the case of composting 40 tons (35 metric tons) per day of organi materials derived from solid waste, an open windrow composting system wou require about 4.5 acres (20,000 square meters), exclusive of land requirements for preprocessing and postprocessing operations and storage finished compost. An enclosed composting system would require less land than an open windrow system, but would require a greater expenditure for equipment. An illustration of a turned windrow composting operation (utilizing a mechanical turning vehicle) is shown in Figure 12.

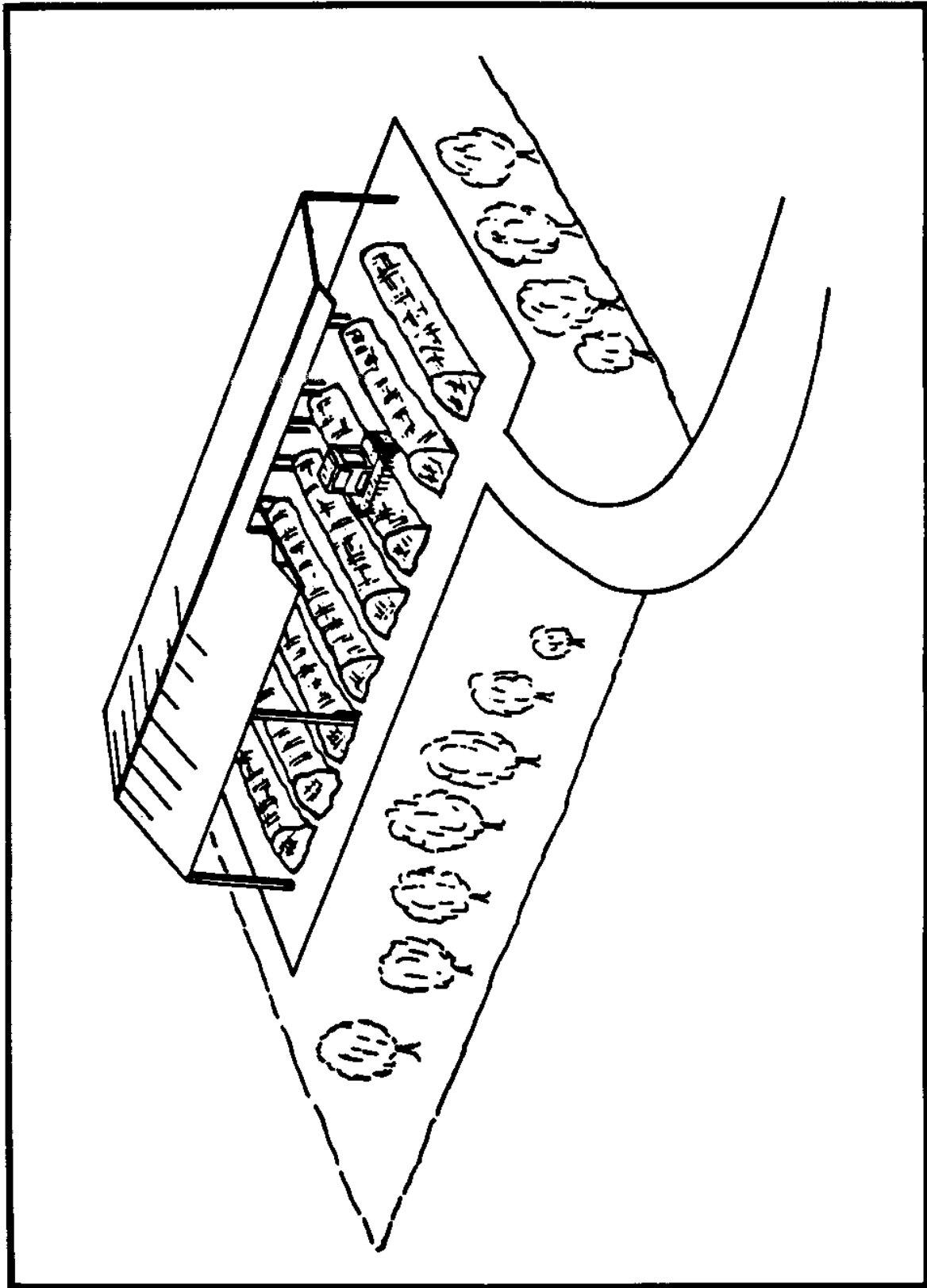

Figure 12  
Turned Windrow Composting Operation

6.3 Costs. The unit costs of refuse processing operations and conversion systems vary considerably depending on the mass throughput and the design of the system. Table 11 presents estimated order-of-magnitude costs for refuse processing operations and conversion systems capable of handling 20 tons (metric tons) per hour. The costs presented in Table 11 include amortization of the equipment, operating and maintenance labor, supplies, and energy.

The cost of a source separation program may be very low (a few dollars per ton) if the program is one in which people deposit their recyclables in bins at a centralized location and the materials are sold with a minimum of processing. On the other hand, a curbside collection program with a moderate amount of material processing may cost on the order of \$20 to \$150 per ton (\$18 to \$135 per metric ton). Administrative, organizational, and publicity efforts may contribute heavily to the cost of a source separation program, particularly in the early stages of the program.

Table 11  
Estimated Costs of Refuse Processing and Conversion Operations[\*]

| Operation                               | Unit cost<br>(\$/ton)[+] |
|---|--------------------------|
| Size Reduction                          | 5                        |
| Air Classification                      | 3                        |
| Screening                               | 1                        |
| Magnetic Separation                     | 1                        |
| Densification                           | 9                        |
| Baling                                  | 2                        |
| Incineration<br>(with steam generation) | 44[#][**]                |
| Composting                              | 40[++]                   |

[\*] Twenty tons per hour (18 metric tons per hour) throughput for each operation.

[+] \$1 Per ton = \$1.1 per metric ton.

[#] Does not include costs of ash disposal wastewater treatment, or utilizing steam or gas.

[\*\*] Feedstock is unprocessed municipal solid waste.

[++] Includes residue disposal and preprocessing and postprocessing.

## Section 7: SANITARY LANDFILLS

7.1 Introduction. Sanitary landfilling is the most acceptable and flexible method for ultimate disposal of solid waste. Other techniques such as land spreading and surface impoundments also provide ultimate waste disposal, these methods are generally more suited to liquid wastes and sludges. Ocean disposal is not practiced primarily because of the high transport costs and the concomitant environmental problems. Incineration, composting, and other processes are often called disposal methods, but cannot be considered as means for ultimate disposal of wastes, since residue from these processes requires disposal on land.

This section presents current technology for the design of sanitary landfills and related engineering considerations.

7.2 Site Selection. When evaluating alternative sites for a sanitary landfill, major technical and economic factors must be considered:

7.2.1 Site Life and Size. The site life is determined by the area of the site, cover soil availability, quantity and characteristics of the solid waste to be delivered, the landfilling method, and the projected in-place density of the compacted solid waste. The usable area of the site is determined by excluding from the gross area land for buffers between the site boundary and the filling area, access roads and soil stockpiles not located on the fill surface, and on-site structures and equipment storage areas. Typically, the usable fill area ranges from 50 to 80 percent of the gross area. Figure 13 is a formula for estimating landfill area requirements.

7.2.2 Location in Relation to Waste Generation Centers. The landfill site should be located as close as possible to areas of solid waste generation. This will reduce haul costs and total exhaust emissions from haul vehicles.

7.2.3 Topography. Landfills can be located in a wide range of terrain, including depressions, areas with relatively flat terrain, and canyons. Sites located in depressions (e.g., abandoned coal strip mines, clay or gravel pits, and natural depressions) generally have little or no cover soil available on-site. Therefore, site capacity for solid waste is reduced by the area of land needed for cover soil. Also, runoff management at depression areas is more critical. Offsite runoff must be diverted around the proposed landfill area. Runoff from incident precipitation in the filling area must be controlled to prevent contact with deposited wastes. If the runoff cannot be evaporated or percolated into site soils, it must be pumped to an offsite drainage channel.

$$\frac{\text{Quantity of Solid Waste (tons)} \times 2000 \text{ lb/ton} \times 27 \text{ (ft}^3\text{/yd}^3)}{\text{Density of Solid Waste (lb/yd}^3\text{)} \times \text{Depth of Solid Waste (ft)}} + \frac{\text{Volume of Cover (yd}^3\text{)} \times 27 \text{ ft}^3\text{/yd}^3}{\text{Average Depth of Cover (ft)}} = \text{Area Required (ac)}$$

43,560 ft<sup>2</sup>/acre

- (1) Soil cover volume/area requirements should not be included in formula if soil cover is to come from on-site areas that will be filled over.
- (2) See Section 7 for discussion on cover soil requirements (as rule of thumb, assumption is 1 part soil to 3 parts solid waste [by volume]).
- (3) In-place waste density generally ranges from 800 to 1200 lb/yd<sup>3</sup> (see Subparagraph 7.5.2 for attainable compaction densities with various equipment).
- (4) 1 ac = 0.4047 ha; 1 ton = 0.90718 metric tons; 1 lb = 453.6 grams; 1 ft<sup>3</sup> = 0.02832 m<sup>3</sup>; 1 yd<sup>3</sup> = 0.7646 m<sup>3</sup>; 1 ft = 0.308 m; 1 ft<sup>2</sup> = 0.093 m<sup>2</sup>.

Figure 13  
Formula for Determining Landfill Area Requirements

When a flat site is used for landfilling, the final site surface generally forms a mound above the surrounding grade. This is done to optimize filling capacity of the site. The final height of the mound is generally a function of aesthetics and availability of cover soil. Cover soil is generally obtained from excavation of onsite soils. The depth and areal extent of excavation is dependent on several factors including the ease of soil excavation, the depth to groundwater, and the ultimate height of the fill surface. Unless there is a ready demand for soil at another location, a balance is made between the volume of cover soil excavated and the soil required for landfill cover or other onsite uses (e.g., construction of a noise control berm). Offsite drainage must also be diverted around this type of site, especially when filling operations are being carried out in the excavated area. Figure 14 illustrates a disposal site constructed in this manner.

Canyon areas offer an ideal location for solid waste disposal provide that runoff from surrounding slopes is diverted around the disposal area, thereby preventing washouts, and sufficient soil is available on the canyon bottom and side slopes for use as waste cover, thereby allowing full canyon capacity for solid waste disposal.

7.2.4 Surface Water and Susceptibility to Flooding. Existing bodies of surface water and water courses on or near proposed sites should be mapped. Current and planned future use of this water should be determined. Certain areas such as wetlands and floodplains should be avoided whenever possible. Where it is necessary to construct a sanitary landfill in either wetlands or floodplains, the proponent should be prepared to provide for extensive water pollution controls, provide operational control of runoff and infiltration, investigate and project environmental conditions, and allow sufficient time to obtain approvals from regulatory agencies.

7.2.5 Soil. Soils to be used at a sanitary landfill and the site geology should be thoroughly characterized. Ideally, the site should have a sufficient volume of soil of suitable properties that can be used for all waste covering (daily, intermediate, and final) throughout the life of the landfill. Alternatively, soil can be imported from offsite locations, but importation can be expensive and off-site soils may not be readily available.

The ease by which the onsite soil can be excavated is a major consideration. For example, excavation of bedrock or hardpan is costly, the material is not well suited for cover. Seasonal variations in workability should be considered; soils with fines may be easy to excavate when moist, but may be like hardpan when dry or frozen. Important soil characteristics such as compaction, drainage, and slope stability are summarized in Table 12. Soil types will also influence vertical and lateral landfill gas migration from the site.

The design engineer must evaluate these design criteria when determine which soil type or types are best suited for the site's operating and environmental conditions. For example, in a dry, arid climate where leachate generation is not a problem, high-permeability soils may be used for cover. In addition, if there is development around the landfill that would be adversely impacted by lateral migration of landfill gas, high-permeability cover soil may be desirable to promote upward migration of gas from the site.

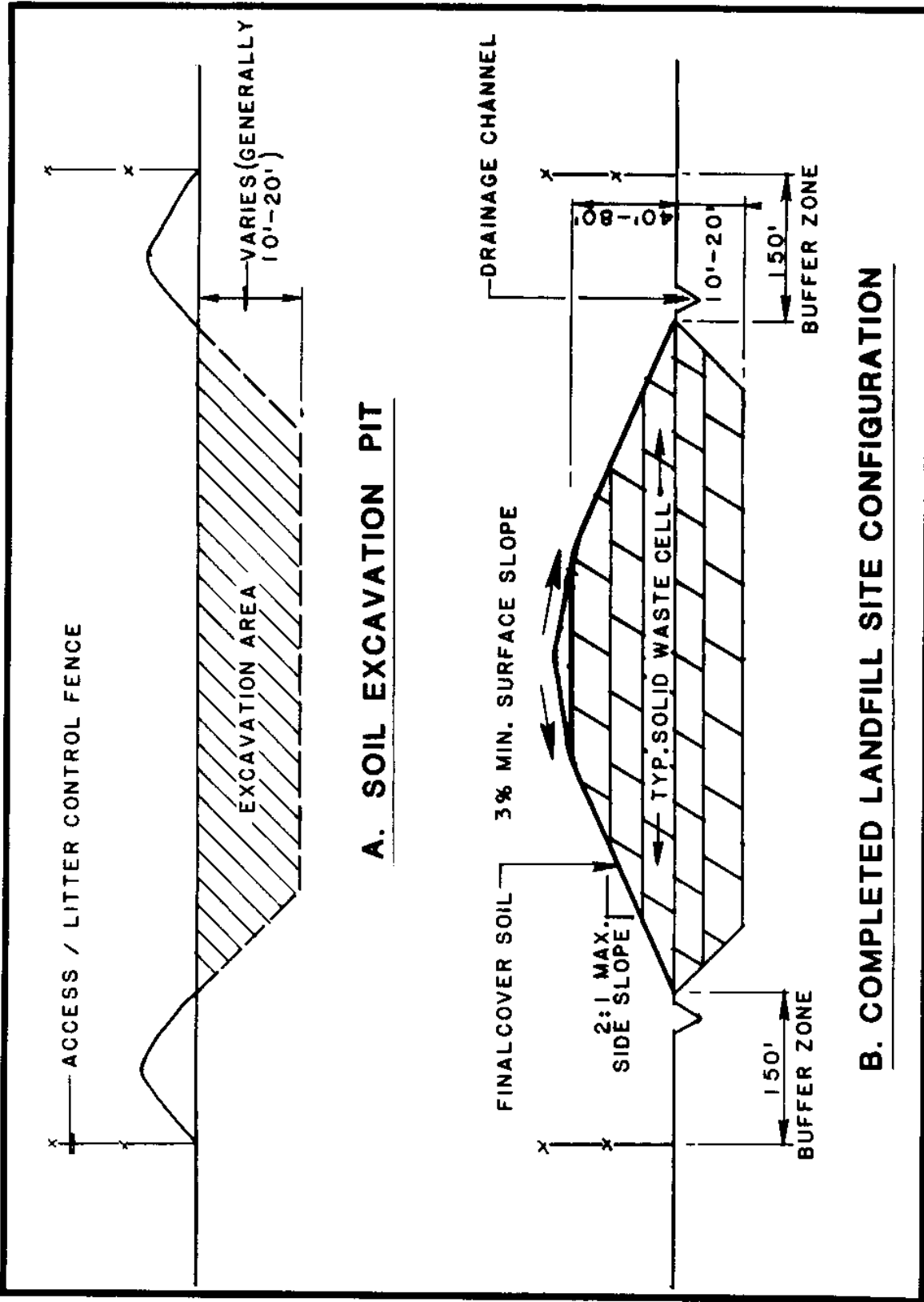

**A. SOIL EXCAVATION PIT**

**B. COMPLETED LANDFILL SITE CONFIGURATION**

Figure 14  
Landfill Constructed on Flat Terrain

Table 12  
 Ranking of USCS Soil Types According to Performance  
 of Landfill Cover Functions\*

| USCS<br>Symbol | Typical Soils   | Trafficability |              | Water Permeability               |                 | Gas Migration |        |
|----------------|---|----------------|--------------|----------------------------------|-----------------|---------------|--------|
|                |   | Stickiness     | Slipperiness | Impede<br>(k, cm/s) <sup>†</sup> | Assist          | Impede        | Assist |
| GW             | Well-graded gravels, gravel-sand mixtures, little or no fines   | I*             | I            | $k > 10^{-2}$                    | III             | X             | I      |
| GP             | Poorly graded gravels, gravel-sand mixtures, little or no fines   | I              | I            | $k > 10^{-2}$                    | I               | IX            | II     |
| GM             | Silty gravels, gravel-sand-silt mixtures  | III            | III          | $k = 10^{-3}$<br>to $10^{-6}$    | VI              | VII           | IV     |
| GC             | Clayed gravels, gravel-sand-clay mixtures   | VI             | V            | $k = 10^{-6}$<br>to $10^{-8}$    | VIII            | IV            | VII    |
| SW             | Well-graded sands, little or no fines   | II             | II           | $k > 10^{-3}$                    | IV              | VIII          | III    |
| SP             | Poorly graded sands, gravelly sands, little or no fines   | II             | II           | $k > 10^{-3}$                    | II              | VII           | IV     |
| SM             | Silty sands, sand-silt mixtures   | IV             | VI           | $k = 10^{-3}$<br>to $10^{-6}$    | V               | VI            | V      |
| SC             | Clayey sands, sand-clay mixtures  | VII            | VI           | $k = 10^{-6}$<br>to $10^{-8}$    | VII             | V             | VI     |
| ML             | Inorganic silts and very fine sands, rock flour, silty or clayey fine sands, or clayey silts with slight plasticity | V              | VII          | $k = 10^{-3}$<br>to $10^{-6}$    | IX              | III           | VIII   |
| CL             | Inorganic clays of low to medium plasticity, gravelly clays, sandy clays, silty clays, lean clays                   | VIII           | VIII         | $k = 10^{-6}$<br>to $10^{-8}$    | XI              | II            | IX     |
| OL             | Organic silts and organic silty clays of low plasticity   | V              | VII          | $k = 10^{-4}$<br>to $10^{-6}$    | NR <sup>‡</sup> | NR            | NR     |
| NH             | Inorganic silts, micaceous or diatomaceous fine sandy or silty soils, elastic silts                                 | IX             | IX           | $k = 10^{-4}$<br>to $10^{-6}$    | X               | NR            | NR     |
| CH             | Inorganic clays of medium to high plasticity, organic silts   | X              | X            | $k = 10^{-6}$<br>to $10^{-8}$    | XII             | I             | X      |
| OH             | Organic clays of medium to high plasticity, organic silts   | NR             | NR           | $k = 10^{-6}$<br>to $10^{-8}$    | NR              | NR            | NR     |
| Pt             | Peat and other highly organic soils   | NR             | NR           | NR                               | NR              | NR            | NR     |

**Table 12 (continued)**  
**Ranking of USCS Soil Types According to Performance**  
**of Landfill Cover Functions\***

| USCS<br>Symbol | Side Slope  |   |          | Discourage<br>Burrowing | Impede<br>Vector<br>Emergence | Discourage<br>Birds <sup>++</sup> | Support<br>Vegetation | Future Use |            |
|----------------|-------------|---|----------|-------------------------|-------------------------------|-----------------------------------|-----------------------|------------|------------|
|                | Stability** | Seepage                                     | Drainage |                         |                               |                                   |                       | Natural    | Foundation |
| GW             |             | k > 10 <sup>-2</sup>                        | III      | I                       | X                             |                                   | X                     | X          | I          |
| GP             |             | k > 10 <sup>-2</sup>                        | I        | I                       | X                             |                                   | X                     | X          | I          |
| GH             |             | k = 10 <sup>-3</sup><br>to 10 <sup>-4</sup> | VI       | III                     | VIII                          |                                   | VI                    | VI         | III        |
| GC             |             | k = 10 <sup>-4</sup><br>to 10 <sup>-8</sup> | VIII     | V                       | V                             |                                   | V                     | V          | V          |
| GW             |             | k > 10 <sup>-3</sup>                        | IV       | II                      | IX                            |                                   | IX                    | IX         | I          |
| GP             |             | k > 10 <sup>-3</sup>                        | II       | IX                      | IX                            |                                   | IX                    | IX         | I          |
| GH             |             | k = 10 <sup>-3</sup><br>to 10 <sup>-4</sup> | V        | VI                      | VII                           |                                   | II                    | II         | II         |
| GC             |             | k = 10 <sup>-4</sup><br>to 10 <sup>-8</sup> | VII      | VI                      | IV                            |                                   | I                     | I          | I          |
| ML             |             | k = 10 <sup>-3</sup><br>to 10 <sup>-6</sup> | IX       | VII                     | VI                            |                                   | III                   | III        | III        |
| CL             |             | k = 10 <sup>-6</sup><br>to 10 <sup>-8</sup> | XI       | VIII                    | III                           |                                   | VII                   | VII        | VII        |
| GL             |             | k = 10 <sup>-4</sup><br>to 10 <sup>-6</sup> | NR       | VII                     | VI                            |                                   | IV                    | IV         | IV         |
| MY             |             | k = 10 <sup>-4</sup><br>to 10 <sup>-6</sup> | X        | IX                      | II                            |                                   | IV                    | IV         | IV         |
| CH             |             | k = 10 <sup>-5</sup><br>to 10 <sup>-8</sup> | XII      | X                       | I                             |                                   | VIII                  | VIII       | VIII       |
| OH             |             | k = 10 <sup>-4</sup><br>to 10 <sup>-8</sup> | NR       | NR                      | NR                            |                                   | VIII                  | VIII       | VIII       |
| PL             |             | NR  | NR       | NR                      | NR                            |                                   | NR                    | NR         | NR         |

**Table 12 (continued)**  
**Ranking of USCS Soil Types According to Performance**  
**of Landfill Cover Functions\***

| USCS<br>Symbol | Fire<br>Resistance | <u>Erosion Control</u> |      | Dust<br>Control | <u>Reduce Freeze Action</u> |                       | Crack<br>Resistance |
|----------------|--------------------|------------------------|------|-----------------|-----------------------------|-----------------------|---------------------|
|                |                    | Water                  | Wind |                 | Fast Freeze                 | Saturation<br>(Heave) |                     |
| GW             | X                  | I                      | I    | I               | II                          | I                     | I                   |
| GP             | IX                 | I                      | I    | I               | IX                          | I                     | I                   |
| GM             | VII                | IV                     | III  | III             | VII                         | IV                    | III                 |
| GC             | IV                 | III                    | V    | V               | IV                          | VII                   | V                   |
| SW             | VIII               | II                     | II   | II              | VIII                        | II                    | I                   |
| SP             | VII                | II                     | II   | II              | VII                         | II                    | I                   |
| SM             | VI                 | VI                     | IV   | IV              | VI                          | V                     | II                  |
| SC             | V                  | VII                    | VI   | VI              | V                           | VI                    | IV                  |
| ML             | III                | XIII                   | VII  | VII             | III                         | X                     | VI                  |
| CL             | II                 | XII                    | VIII | VIII            | II                          | VIII                  | VIII                |
| OL             | MR                 | XI                     | VII  | VII             | MR                          | VIII                  | VII                 |
| MN             | MR                 | X                      | IX   | IX              | MR                          | IX                    | IX                  |
| CH             | I                  | IX                     | X    | X               | I                           | XII                   | X                   |
| OH             | MR                 | VIII                   | MR   | MR              | MR                          | MR                    | IX                  |
| PL             | MR                 | V                      | MR   | MR              | MR                          | MR                    | MR                  |

\* The ratings I to XIII are for best through poorest in performing the specified cover function.

+ k = Coefficient of permeability.

# MR = Not ranked.

\*\* Determined on basis of laboratory testing.

†† All soils are suitable.

The role of soil in landfills is to:

a) Provide Cover. Table 13 presents a system for ranking soil types according to the United Soil Classification System (USCS) in relation to landfill cover factor. Cover soil serves several functions including:

- 1) Control of water infiltration which in turn effects leachate production.
- 2) Support of vegetative growth.
- 3) Encapsulation of the deposited waste to isolate it from the local environment, and to reduce odor emissions and aesthetic impacts.
- 4) Impedance of fire propagation from cell to cell.

b) Attenuate Potential contaminants. Soil pH and cation exchange capacity (CEC) influence the ability of a soil to attenuate cations in leachate that may form. CEC and pH are influenced by clay content, free iron oxide content, organic matter, the lime concentration of a soil, and soil permeability. In general, as CEC and pH increase, heavy metals are more readily retained. Similarly, as the clay content, free iron oxide content, and lime concentration of a soil increase, its pH and CEC (i.e., attenuation capacity) generally increase. Table 14 shows typical ranges CEC values in various soils.

Soils can be modified to enhance their attenuation capacity. The easiest approach is to apply lime to the soil surface, which increases pH. The clay and free iron oxide content can also be modified, but with great difficulty and questionable success. Recent studies show that metal concentrations in leachate decrease when flow rates (or flux rates) decrease; however, further research is needed to determine the mechanisms associated with this phenomena and the others discussed above.

7.2.6 Geology. The geology of a site is an important consideration. Formations that have faults, major fractures, joint systems, and other discontinuities or are soluble should be avoided or provisions made in the landfill design to protect against groundwater contamination, if required. In general, limestone, dolomite, and heavily fractured crystalline rock are less desirable than siliceous sandstone, siltstone, and other consolidated alluvial bedrock.

7.2.7 Groundwater. Information required in assessing the groundwater conditions of a site should include:

a) Depth to groundwater from the bottom of the fill (including historical highs and lows), and knowledge of the properties of subgrade soils.

b) Direction of groundwater movement. By knowing the direction of groundwater movement under the site, potential impacted areas can be identified, and locations for onsite groundwater monitoring wells can be determined. Subsequently, when more specific site studies are conducted, hydraulic gradients can be computed.

c) Quality and availability of groundwater, its current and projected use, and the location of primary recharge and discharge zones. Example, a good landfill location may be a site overlying poor-quality low-yielding groundwater where the groundwater basin does not discharge to nearby water course.

Table 13  
Soil Characteristic Pertinent to Solid Waste Landfills, USCS

| USCS Symbol | Color  | Name  | Drainage Characteristics <sup>f</sup> | Value of Embankments  | Permeability cm per sec    | Compaction Characteristics <sup>g</sup>  | SLD ASTM Max Unit Dry Weight lb per cu ft <sup>h</sup> |
|-------------|--------|---|---------------------------------------|---|----------------------------|--|--|
| GM          | Red    | Well-graded gravels or gravel-sand mixtures, little or no fines                                   | Excellent                             | Very stable, pervious shells of dikes and dams  | $k > 10^{-2}$              | Good, tractor, rubber-tired steel-wheeled roller                               | 125-135  |
| GP          |        | Poorly graded gravels or gravel-sand mixtures, little or no fines                                 | Excellent                             | Reasonably stable, pervious shells of dikes and dams  | $k > 10^{-2}$              | Good, tractor, rubber-tired steel-wheeled roller                               | 115-125  |
| GM          |        | Silty gravels, gravel-sand-silt mixtures  | Fair to poor                          | Reasonably stable, not particularly suited to shells, but may be used for embankments or blankets | $k = 10^{-3}$ to $10^{-4}$ | Good, with close control, rubber-tired sheepsfoot roller                       | 120-135  |
| GC          | Yellow | Clayed gravels, gravel-sand-clay mixtures   | Poor to practically impervious        | Fairly stable, may be used for impervious core  | $k = 10^{-4}$ to $10^{-8}$ | Fair, rubber-tired, sheepsfoot roller  | 115-130  |
| SM          | Red    | Well-graded or gravelly sands little or no fines  | Excellent                             | Very stable, pervious sections slope protection required  | $k > 10^{-3}$              | Good, tractor  | 110-130  |
| SP          | Red    | Poorly graded sands or gravelly sands, little or no fines   | Excellent                             | Reasonably stable, may be used in dike section with flat slopes                                   | $k > 10^{-3}$              | Good, tractor  | 100-130  |
| SM          | Yellow | Silty gravels, sand-silt mixtures   | Fair to poor                          | Fairly stable, not particularly suited to shells, but may be used for impervious cores or dikes   | $k = 10^{-3}$ to $10^{-4}$ | Good, with close control, rubber-tired, sheepsfoot roller                      | 110-125  |
| SC          |        | Clayed sands, sand-clay mixtures  | Poor to practically impervious        | Fairly stable, may be used for impervious core (for flood control structures)                     | $k = 10^{-4}$ to $10^{-8}$ | Fair, sheepsfoot roller, rubber-tired  | 105-125  |
| ML          |        | Inorganic silts and very fine sands rock flour, silty or clayed fine sands with slight plasticity | Fair to poor                          | Poor stability, may be used for embankments with proper control                                   | $k = 10^{-3}$ to $10^{-4}$ | Good to poor, close control essential, rubber-tired, roller, sheepsfoot roller | 95-120   |
| CL          | Green  | Inorganic clays of low to medium plasticity, gravelly clays, sandy clays, silty clays loam clays  | Practically impervious                | Stable, impervious cores and blankets   | $k = 10^{-4}$ to $10^{-8}$ | Fair to good, sheepsfoot roller, rubber-tired                                  | 95-120   |
| OL          |        | Organic silts and organic silt-clays of low plasticity  | Poor                                  | Not suitable for embankments  | $k = 10^{-4}$ to $10^{-6}$ | Fair to good, sheepsfoot roller  | 80-100   |
| MH          |        | Inorganic silts, micaceous or diatomaceous fine sandy or silty soils, elastic silts               | Fair to poor                          | Poor stability, core of hydraulic dam, not desirable in rolled fill construction                  | $k = 10^{-4}$ to $10^{-4}$ | Poor to very poor, sheepsfoot roller   | 70-95  |
| OH          | Blue   | Inorganic clays of high plasticity, fat clays   | Practically impervious                | Fair stability with flat slopes, thin cores, blankets, and dike sections                          | $k = 10^{-4}$ to $10^{-4}$ | Fair to poor, sheepsfoot roller  | 75-105   |
| OR          |        | Organic clays of medium to high plasticity, organic silts   | Practically impervious                | Not suitable for embankments  | $k = 10^{-4}$ to $10^{-8}$ | Poor to very poor, sheepsfoot roller   | 65-100   |
| OL          | Orange | Peat and other highly organic soils   |                                       | Not Recommended for Landfill Construction   |                            |  |  |

<sup>f</sup> Values are for guidance only; design should be based on test results.

<sup>g</sup> The equipment listed will usually produce the desired densities after a reasonable number of passes when moisture conditions and thickness of lift are controlled.

<sup>h</sup> Compacted soil at optimum moisture for Standard ASTM (Standard Proctor) 60g compactive effort.

**Table 14**  
**Attenuation Properties of Representative Soil Series**

| Series              | Order*   | Solid Waste pH | Cation Exchange Capacity (meq/100 g) | Electrical Conductivity of Extract (μmhos/cm) | Column Bulk Density (g/cm <sup>3</sup> ) | Surface Area (m <sup>2</sup> /g) | Free Iron Oxides (%) | Total Mn (mg/l) | Texture (%)† |           | Major Clay Minerals‡ |                              |
|---------------------|----------|----------------|--------------------------------------|---|--|----------------------------------|----------------------|-----------------|--------------|-----------|----------------------|------------------------------|
|                     |          |                |                                      |   |  |                                  |                      |                 | Sand         | Silt Clay |                      |                              |
| Wagram              | Ultisol  | 4.2            | 2                                    | 225   | 1.89                                     | 8.0                              | 0.6                  | 50              | 88           | 8         | 4                    | Kaolinite, Chlorite          |
| Avs                 | Alfisol  | 4.5            | 19                                   | 157   | 1.45                                     | 61.5                             | 4.0                  | 360             | 10           | 60        | 31                   | Vermiculite, Kaolinite       |
| Kalkaska            | Spodosol | 4.7            | 10                                   | 237   | 1.53                                     | 8.9                              | 1.8                  | 80              | 91           | 4         | 5                    | Chlorite, Kaolinite          |
| Davidson            | Ullisol  | 6.2            | 9                                    | 169   | 1.89                                     | 51.3                             | 17.0                 | 4,100           | 19           | 20        | 61                   | Kaolinite                    |
| Molokai             | Oxisol   | 6.2            | 14                                   | 1,262   | 1.44                                     | 67.3                             | 23.0                 | 7,400           | 23           | 25        | 52                   | Kaolinite, Gibbsite          |
| Chalmers            | Mollisol | 6.6            | 26                                   | 288   | 1.60                                     | 125.6                            | 3.1                  | 330             | 7            | 48        | 35                   | Montmorillonite, Vermiculite |
| Micholson           | Alfisol  | 6.7            | 37                                   | 176   | 1.53                                     | 120.5                            | 5.6                  | 950             | 3            | 47        | 49                   | Vermiculite                  |
| Fanno               | Alfisol  | 7.0            | 33                                   | 392   | 1.48                                     | 122.1                            | 3.7                  | 280             | 35           | 19        | 46                   | Montmorillonite, Mica        |
| Mohave              | Aridisol | 7.3            | 10                                   | 615   | 1.78                                     | 38.3                             | 1.7                  | 825             | 52           | 37        | 11                   | Mica, Kaolinite              |
| Mohave (calcareous) | Aridisol | 7.8            | 12                                   | 510   | 1.54                                     | 127.5                            | 2.5                  | 770             | 32           | 28        | 40                   | Mica, Montmorillonite        |
| Anthony             | Entisol  | 7.8            | 6                                    | 328   | 2.07                                     | 19.8                             | 1.8                  | 275             | 71           | 14        | 15                   | Montmorillonite              |

\* U.S. Department of Agriculture Comprehensive Soil Classification System.

† U.S. Department of Agriculture System: Sand = 2 to 0.05 mm diameter; silt = 0.05 to 0.002 mm diameter; clay = < 0.002 mm diameter.

‡ The dominant mineral is listed first.

Solid waste should not be placed where there is a potential for direct contact with the groundwater table. Also, major recharge zones should be eliminated from consideration, particularly in areas overlying Environmental Protection Agency (EPA)-designated sole source aquifers which do or would provide significant quantities of drinking water. The separation between the bottom of the fill and the highest known level of groundwater should be maximized. State and local regulation may stipulate minimum acceptable separation. A 5-foot (1.5-meter) separation is a common regulatory stipulation, but may vary from state to state.

Sources of data on groundwater quality and movement include the U.S. Geological Survey (USGS), local well drillers, USDA soil surveys, state geological surveys, state health departments, other state environmental regulatory agencies, and samplings from nearby wells. USGS maintains a National Water Data Exchange (NAWDEX) which is developed from the National Water Data Storage and Retrieval System (WATSTORE) and contains EPA as well as USGS well and groundwater data. NAWDEX reports can be obtained from USGS headquarters on magnetic tape or computer printout or from any of the 79 regional USGS, NAWDEX, offices located in most states. Contact USGS headquarters for regional office locations or NAWDEX reports.

Determining the hydraulic gradient at a site is important in ascertaining the rate and direction of groundwater movement and whether or not hydraulic connections to surrounding aquifers exist. The hydraulic gradient can be determined by noting the depth to groundwater in nearby wells or borings, calculating the elevation of the groundwater, and drawing contour lines that connect wells of equal groundwater elevations.

Further background information on groundwater can be obtained through onsite drilling. At least three wells (and normally more) are needed to determine the direction of groundwater movement. Large sites, sites with complex hydrogeology, and relatively flat sites require more borings than small and steep sites. An experienced hydrogeologist should participate in planning the drilling program and in interpretation of background research and exploratory drilling.

**7.2.8 Vegetation.** The amount and type of existing vegetation on a prospective site should be considered in the selection process. Natural vegetation left at the site can serve to reduce dust, noise, odor, and visibility problems. Where extensive clearing and grubbing of vegetation is necessary, costs may increase significantly. Also, some areas may be habitats for endangered plant (and animal) species.

Vegetation can be planted during site operations to screen the site. Upon site closure, the filled areas can be replanted with either native or introduced species. The ability of soil, used as the final cover, to support planned revegetation should therefore be considered.

**7.2.9 Site Proximity and Accessibility.** A landfill site should be located as close as practical to the waste generation centroid since hauling costs are a significant part of total solid waste management costs.

The haul routes to the prospective sites should be over major roads to the installation to the maximum extent possible. The proximity of the site to these major roads is also a consideration since a well-graded onsite access road must be constructed from the haul route to the disposal area.

7.3 Land Use in the Area, Including Future Land Use Classification by the Respective Planning Jurisdiction(s). Compatibility of a sanitary landfill with existing and proposed surrounding site use should be considered. This is true both when the site is being operated as a landfill and after the site is closed. Completed landfills are generally converted to recreational end uses, though other uses (such as light industry) are also common.

Regional development in the larger community should also be considered in site selection, and existing master plans for the area should be consulted. For example, the evaluation of current and future development may present the opportunity for a more strategically centralized location offsite wastes will be deposited in the landfill. Moreover, the projected rate of industrial and municipal development and its location affect the size of the site needed to meet projected waste disposal demands.

7.3.1 Archaeological or Historic Significance. The archaeological or historical significance of the land involved in a potential site should be ascertained. The historical status of a potential site is usually addressed in an environmental impact report and should be performed by a qualified archaeologist or anthropologist. Due to the expense involved in such studies, archaeological and historical investigations are usually limited to the top ranking candidate sites. Excavation and preservation of significant archaeological finds must be arranged before the site can be approved and construction can begin.

7.3.2 Susceptibility to Flooding. Locating a landfill in a floodplain should be avoided, if possible. EPA, criteria for Classification of Solid Waste Disposal Facilities and Practices, 40 CFR 257, requires that waste disposal activities in floodplains shall not restrict the 100-year flood flow, reduce the floodplains temporary storage capacity, or result in a washout of solid waste so as to pose a hazard to human life, wildlife, land, or water.

To determine the upstream and downstream impact of landfilling within floodplain, a hydrological investigation should be conducted. The study should identify the prospective solid waste and existing floodplain boundaries, present hydrologic and hydraulic calculations, and locate the properties and activities that could be adversely affected by floodplain modifications. The study should also identify methodologies (e.g., dikes) for protecting the disposal site against flooding. A thorough study will also assess the potential hazards to human life, wildlife, land, and water.

7.3.3 Public Health and Safety. Sanitary landfills can affect public health and safety in several ways presented below.

7.3.3.1 Attractive Nuisance. Sites should be situated and designed to restrict access by unauthorized persons. Scavenging through deposited waste should be prohibited to prevent injury or death to scavengers.

7.3.3.2 Bird Hazards. Land disposal of putrescible wastes may attract birds. A solid waste disposal facility should be located no closer than 10,000 feet (3050 meters) from airports serving jet aircraft, and 5,000 feet (1,525 meters) from airports serving only propeller aircraft. These distances are stipulated by EPA to minimize the opportunity for birds fly from and to landfills to intercept a landing or departing airplane. Solid waste disposal sites within this "danger zone," as detailed by the Federal Register, are not prohibited, but special precautions must be taken to assure that bird hazards resulting from solid waste disposal do not occur.

7.3.4 Costs. Early in the selection process, the relative costs of alternative sites should be estimated for comparison. For valid cost comparisons, three cost elements should be estimated: capital costs over the life of the site, annual operating costs, and waste haul costs.

Capital costs should include primarily:

- a) Survey and geology work.
- b) Design engineering and Environmental Impact Statement (EIS) preparation.
- c) Legal costs (permitting, etc.).
- d) Land acquisition.
- e) Site improvement overhead (SIOH).
- f) Site preparation.
- g) Monitoring well installation.
- h) Equipment purchases (initial and recurring replacements).

Annual operating costs should be estimated for:

- a) Labor and benefits.
- b) Equipment, fuel, maintenance, and parts.
- c) Utilities.
- d) Laboratory analysis of water samples.
- e) Closure and postclosure operations.

Haul costs include estimates of the cost to transport wastes from point of generation to the disposal site. This cost would be higher as the distance increases. If a transfer station is used, the haul cost would include both the costs for station ownership/operation and the transport to the landfill by transfer rigs.

Once all of these costs are determined, the capital costs should be annualized and a life cycle cost estimate developed to allow direct comparison between sites with different site lives.

7.3.5 Site Selection Methodology. Candidate sites for a new sanitary landfill can be selected in the study area by first eliminating all unsuitable areas. Unsuitable areas include those that are already developed or set aside for other uses, areas with undesirable geology, soils, or surface or groundwater conditions (e.g., floodplains), areas with limited site capacity, and critical flora or fauna habitat, or archaeologically known areas.

Once several candidate sites have been selected for further consideration as sanitary landfills, they are assessed in relation to the criteria discussed above. A rating system similar to that outlined for transfer station site selection (see Section 5) can also be used for screening alternative sanitary landfill sites.

#### 7.4 Sanitary Landfill Design.

7.4.1 Introduction. This section provides guidance on design considerations for a sanitary landfill. The objectives of a landfill design are to:

- a) Ensure compliance with pertinent regulatory guidelines and requirements.
- b) Provide adequate present and long-term protection of the environment.
- c) Achieve cost-efficient utilization of site manpower, equipment, volume, and soil.
- d) Direct and guide operators toward proper construction and operation of the landfill.

7.4.2 Regulations and Permits. Many regulatory and approving agencies require permits before a landfill can be constructed or operated.

Permit requirements of state and local agencies vary depending on jurisdiction. In some areas, only one permit is needed. Other states may require several separate permits or stipulate that a new sanitary landfill proponent coordinate with several agencies.

Sanitary landfill regulations can be the responsibility of one or more state agencies. Table 1 (see Section 1) lists the various state agencies (including addresses and telephone numbers) responsible for solid waste disposal activities in those states.

Local regulatory agencies having regulatory authorization are given in Table 15.

The reviewing agency may require the submittal of information on standard forms or in a prescribed format in order to facilitate the review process. This process can take at least 1 month and usually 6 to 12 months or longer, depending on the degree of controversy and opposition. A conceptual landfill design is generally an integral part of the application for such permits. Accordingly, all pertinent agencies should be contacted early in the design phase to:

- a) Identify regulations impacting on the prospective landfill.
- b) Determine the extent, detail, and format of the application.
- c) Obtain permit application forms and other background information.

Table 15  
 Typical Local Regulatory Agencies Having Responsibility  
 for Sanitary Landfill Practices

| Agency                             | Responsibility   |
|------------------------------------|--|
| Health Departments                 | Assure that landfill operations do not be a hazard to public health. Issue operating permits. Permits periodically reviewed and renewed. |
| Planning and/or Zoning Commissions | Assure that potential landfills are compatible with existing and proposed land uses.   |
| Building Departments               | Regulate building construction on or near landfill sites.  |
| Highway Departments                | Assure that access highways to landfills can accommodate landfill truck traffic.   |
| Fire Department                    | Assure that fire breaks are provided around landfilling operations and that a fire safety plan is filed.                                 |

Two permits relevant to landfills are identified and mandated by these criteria: the National Pollutant Discharge Elimination System (NPDES) permit (402 and 404), and the Army Corps of Engineers Permit. The NPDES permit is required for location of a landfill in waters of the United States. It is also required for any point source discharges from sanitary landfills, such as from leachate collection systems. Army Corps of Engineers permit is required for the construction of any levee, dike, or other type of containment structure to be placed at a sanitary landfill located in waters of the United States.

7.4.3 Design Methodology and Data Compilation. Adherence to a carefully planned sequence of activities to develop a landfill design minimizes project delays and expenditures. A checklist of design activities is presented in Table 16, to aid in planning the design effort. These activities are listed in their general order of performance, but the order can vary considerably from site to site and from jurisdiction to jurisdiction, depending on specific conditions.

As shown in Table 16, initial tasks consist of compiling existing information and generating new information on solid waste characteristics and site conditions. Obviously, some of this information would have already been collected in the site selection phase. Generally, additional and more detailed information will have to be collected in the design phase. A listing of possible sources for existing information is shown on Table 17. A summary of methods to obtain new information is shown on Table 18.

Throughout the design phase, it is advisable to periodically contact regulatory agency representatives who participated in the site selection process to ensure that the design will meet any new requirements and procedures for permit application submittals. Maintenance of close liaison with state and local regulatory officials throughout the design effort is helpful in securing a permit without excessive redesigns, especially at a time when environmental protection legislation and regulations are rapidly changing.

Two general types of design packages are prepared for a sanitary landfill: conceptual or preliminary design plans, and construction documents. Conceptual design plans normally consist of the following elements provided in sufficient detail to describe proposed filling plans to regulatory agencies and the public. The conceptual design can also serve as a guide for landfilling operations in the event that design construction drawings are not required. Conceptual design plans include:

a) An installation map showing existing site conditions. The map should be of sufficient detail, with contour intervals of 1 foot (0.3 meter) to 5 feet (1.5 meters) and a scale of 1 inch = 50 feet (10 millimeter = 6 meters) to 1 inch = 200 feet (10 millimeter = 24 meters), depending on the steepness of the terrain and size of the landfill, respectively.

b) A site preparation plan locating the areas and depths designated for cover soil excavation and soil stockpile deposits. Also shown are site facilities locations such as structures, access roads, and utilities.

c) Development plans showing final filling and excavation contours. Development plans should show interim (4- to 6-year) filling and excavation contours if a long-lived site is planned.

Table 16  
Solid Waste Landfill Design Checklist

| Step | Task  |
|------|---|
| 1    | Determine solid waste quantities and characteristics <ul style="list-style-type: none"> <li>a. Existing</li> <li>b. Projected</li> </ul>  |
| 2    | Compile existing and generate new site information <ul style="list-style-type: none"> <li>a. Perform boundary and topographic survey</li> <li>b. Prepare base map of existing conditions onsite and near the site               <ul style="list-style-type: none"> <li>(1) Property boundaries</li> <li>(2) Topography and slopes</li> <li>(3) Surface water</li> <li>(4) Utilities</li> <li>(5) Roads</li> <li>(6) Structures</li> <li>(7) Land use</li> </ul> </li> <li>c. Compile hydrogeologic information and prepare location map               <ul style="list-style-type: none"> <li>(1) Soil (depth, texture, structure, bulk density, porosity, permeability, moisture content, ease of excavation, stability, pH, and cation exchange capacity)</li> <li>(2) Bedrock (depth, classification, presence of fractures, location of surface outcrops)</li> <li>(3) Groundwater (average depth, seasonal fluctuations, hydraulic gradient and direction of flow, rate of flow, quality, uses)</li> </ul> </li> <li>d. Compile climatological data               <ul style="list-style-type: none"> <li>(1) Precipitation</li> <li>(2) Evaporation</li> <li>(3) Temperature</li> <li>(4) Number of freezing days</li> <li>(5) Wind direction</li> </ul> </li> <li>e. Identify regulations (federal, state, and local) and design standards               <ul style="list-style-type: none"> <li>(1) Loading rates</li> <li>(2) Frequency of cover</li> <li>(3) Distances to residences, roads, and surface water</li> <li>(4) Monitoring</li> <li>(5) Roads</li> <li>(6) Building codes</li> <li>(7) Contents of application for permit</li> </ul> </li> </ul> |



Table 16 (Continued)  
Solid Waste Landfill Design Checklist

| Step | Task  |
|------|---|
|      | (1) Excavation plans (including benches)                                    |
|      | (2) Sequential fill plans   |
|      | (3) Completed fill plans  |
|      | (4) Fire, litter, vector, odor, and noise controls                          |
| c.   | Compute solid waste storage volume, soil requirement volumes, and site life |
| d.   | Develop final site plan showing:  |
|      | (1) Normal fill areas   |
|      | (2) Special working areas   |
|      | (3) Leachate controls   |
|      | (4) Gas controls  |
|      | (5) Surface water controls  |
|      | (6) Access roads  |
|      | (7) Structures  |
|      | (8) Utilities   |
|      | (9) Fencing   |
|      | (10) Lighting   |
|      | (11) Washracks  |
|      | (12) Monitoring wells   |
|      | (13) Landscaping  |
| e.   | Prepare elevation plans with cross sections of:                             |
|      | (1) Excavated fill  |
|      | (2) Completed fill  |
|      | (3) Phased development of fill at interim points                            |
| f.   | Prepare construction details  |
|      | (1) Leachate controls   |
|      | (2) Gas controls  |
|      | (3) Surface Water controls  |
|      | (4) Access roads  |
|      | (5) Structures  |
|      | (6) Monitoring wells  |
| g.   | Prepare ultimate land use plan  |
| h.   | Prepare cost estimate   |
| i.   | Prepare design report   |
| j.   | Submit application and obtain required permits                              |
| k.   | Prepare operator's manual   |

Table 17  
Sources of Existing Information

| General Information | Specific Information                        | Source   |
|---------------------|---|--|
| Base Map            | General                                     | County road department   |
|                     |   | City, county, or regional planning department  |
|                     |   | U.S. Geological Survey (USGS) office or outlets for USGC map sales (such as engineering supply stores and sporting goods stores) |
|                     | Topography and Sloper                       | U.S. Department of Agriculture (USDA), Agricultural Stabilization and Conservation Service (ASCS)                                |
|                     |   | Local office of USGS   |
|                     |   | County Department of Agriculture, Soil Conservation Service (SCS) Surveyors and aerial photographers in the area                 |
| Land Us.            | USGS topographic maps                       |  |
|                     | USDA, ARS, SCS aerial photos                |  |
|                     | City, county, or regional planning agency   |  |
| Vegetation          | County agricultural department              |  |
|                     | Agricultural department at local university |  |
| Soils               | General                                     | USDA, Soil Conservation Service (SCS), District Managers, Local Extension Service  |
|                     |   | USGS reports   |
|                     |   | Geology or Agriculture Department of local University  |
| Bedrock             | General                                     | USGS reports   |
|                     |   | State Geological Survey reports  |
|                     |   | Professional geologists in the area  |
|                     |   | Geology Department of local university   |

Table 17 (continued)  
Sources of Existing Information

| General Information             | Specific Information | Source   |
|---------------------------------|----------------------|--|
| Groundwater                     | General              | Water Supply Department                                    |
|                                 |                      | USGS water supply papers                                   |
|                                 |                      | State or regional water quality agencies                   |
|                                 |                      | USDA, SCS  |
|                                 |                      | State or Federal water resources agencies                  |
|                                 |                      | Local health department                                    |
| Climatology                     | General              | National Oceanic and Atmospheric Administration (NOAA)     |
|                                 |                      | Nearby airports  |
| Refuse Composition and Quantity |                      | State and local governments planning agencies, census data |

Table 18  
Field Investigation for blew Information

| General Information      | Specific Information      | Method and Equipment  |
|--------------------------|---------------------------|---|
| Base Flap                | Property Boundaries       | Field survey via transit  |
|                          | Topography                | Field survey via alidade  |
|                          | Surface Water             | Field survey via alidade  |
|                          | Utilities                 | Field survey via alidade  |
|                          | Roads                     | Field survey via alidade  |
|                          | Structures                | Field survey via alidade  |
|                          | Land Use                  | Field survey via alidade  |
|                          | Vegetation                | Field survey via alidade  |
| Soils                    | Depth                     | Soil boring and compilation of boring log                               |
|                          | Classification            | Soil sampling and testing via sedimentation methods (e.g., sieves)      |
|                          | Structure                 | Soil sampling and inspection  |
|                          | Bulk Density              | Soil sampling and testing via gravimetric gamma ray detection           |
|                          | Porosity                  | Calculation using volume of voids and total volume                      |
|                          | Permeability              | Soil sampling and testing via piezometers and lysimeters                |
|                          | Moisture                  | Soil sampling and testing via oven drying                               |
|                          | Ease of Excavation        | Test excavation with heavy equipment                                    |
|                          | Stability                 | Test excavation of trench and loading of sidewall or Hveem stabilometer |
|                          | pH                        | Soil sampling and testing via pH meter                                  |
| Cation Exchange Capacity | Soil sampling and testing |   |

Table 18 (continued)  
Field Investigation for New Information

| UAA |                           |  |
|---|---------------------------|--|
| 3 General   |                           |  |
| 3 Information   | 3 Specific Information    | 3 Method and Equipment                                     |
| 3AA |                           |  |
| 3 Bedrock   | 3 Depth                   | 3 Boring and compilation of boring log                     |
| 3   |                           |  |
| 3   | 3 Type                    | 3 Sampling and inspection                                  |
| 3   |                           |  |
| 3   | 3 Fractures               | 3 Field survey via alidade Brunton                         |
| 3   |                           |  |
| 3   | 3 Surface Outcrops        | 3 Field survey via alidade Brunton                         |
| 3   |                           |  |
| 3 Groundwater   | 3 Depth                   | 3 Well installation and initial readings                   |
| 3   |                           |  |
| 3   | 3 Seasonal Fluctuations   | 3 Well installation and year-round readings                |
| 3   |                           |  |
| 3   | 3 Hydraulic gradient      | 3 Multiple well installation and comparison of reading     |
| 3   |                           |  |
| 3   | 3 Rate of Flow            | 3 Calculation based on permeability and hydraulic gradient |
| 3   |                           |  |
| 3   | 3 Quality                 | 3 Groundwater sampling and testing                         |
| 3   |                           |  |
| 3   | 3 Uses                    | 3 Field survey via inspection                              |
| 3   |                           |  |
| 3 Climatology   | 3 Precipitation           | 3 Rain gauge   |
| 3   |                           |  |
| 3   | 3 Evaporation             | 3 Class A Evaporation Pan                                  |
| 3   |                           |  |
| 3   | 3 Temperature             | 3 Standard thermometer                                     |
| 3   |                           |  |
| 3   | 3 Number of Freezing Days | 3 Minimum-maximum temperature thermometer                  |
| 3   |                           |  |
| 3   | 3 Wind Direction          | 3 Wind arrow   |
| 3   |                           |  |
| AA  |                           |  |

d) Elevations showing cross sections to illustrate excavation and landfill surface development at several locations across the fill. Cross sections should be prepared for each phase of the development plan (i.e., interim and final).

e) Groundwater monitoring well locations, depths, and configurations

f) Details illustrating the types and locations for site facilities undimensioned configurations to be used, including drainage structures, liners, gas control vents, and onsite roads.

g) Conceptual site closure plan indicating the types of vegetation to be used for final site landscaping, onsite appurtenances, and other improvements.

h) A conceptual design report. Topics typically described in a conceptual design report are given in Table 19. Construction designs contain sufficient detail to enable a bid package to be advertised for a contractor to fully construct all plan elements at the appropriate time. For example, drainage structures are completely sized, precise locations noted by coordinates, bearing, and distance or other means; and environmental control systems, including those for leachate and landfill management, are fully designed. A landfill is an ongoing construction project in that its configuration is continually changing until completion. Thus, it is prudent to prepare construction documents for future phase development elements (e.g., a drainage channel) that are dependent on previous landfilling activities only when assured that the configuration location of the element shall not be impacted by landfilling activities prior to their construction.

7.4.4 Design Features. The designer of a solid waste sanitary landfill should prescribe the method of construction and the procedures to be followed in disposing of the solid waste. There is no one "best method" all sites, nor is one single method always best for any given site. The method(s) selected depends on the site's physical conditions and the amount and types of solid waste to be handled.

Virtually all sanitary landfill designs incorporate the solid waste cell as a basic element. All solid waste received is spread in 2- to 3-foot (0.6- to 0.9-meter) layers, and then compacted within a confined area. At the end of each working day, or more frequently, the solid waste cell is covered completely with a continuous compacted layer of soil at least 6 inches (150 millimeters) thick. The compacted waste and soil cover constitute a cell. A series of adjoining cells at the same height make up a lift (see Figure 15). The completed fill consists of one or more lifts.

Cell heights generally range from 8 to 15 feet (2.4 to 4.5 meters), although this range can be exceeded on either end, depending on the daily waste input. When deciding on the optimal lift height the designer should attempt to conserve available cover soil while adequately accommodating as much waste as possible.

Cover soil volume requirements are dependent on the surface area of waste to be covered and the thickness of soil needed to perform particular functions. Cell configuration can greatly affect the volume of cover material needed. The surface area of exposed solid waste to be covered should therefore be kept to a minimum. The width of the working face should be no wider than necessary to allow the delivery vehicles to safely unload without long delays. Typically, this distance is about four to five dozen widths wide.

Table 19  
Topics Typically Described in a Conceptual Design Report

UAA

30 Site Conditions

- 3
- 3 - Existing site
- 3 - Topography and slopes
- 3 - Surface water
- 3 - Utilities
- 3 - Roads
- 3 - Structures
- 3 - Land use
- 3 - Soil and groundwater
- 3 - Subsurface exploration data
- 3 - Bedrock
- 3 - Climatology conditions

30 Design Criteria

- 3
- 3 - Solid waste types and volumes expected
- 3 - Fill area dimensions
- 3 - Site life

30 Operational Procedures to Be Used to Implement Design

- 3
- 3 - Site preparation
- 3 - Solid waste unloading
- 3 - Handling
- 3 - Covering procedures
- 3 - Equipment and personnel requirements

30 Environmental Safeguards

- 3
- 3 - Control of leachate
- 3 - Surface water
- 3 - Gas
- 3 - Blowing paper
- 3 - Odor
- 3 - Vectors

30 Initial Site Preparation and Development Steps

30 Site Closure and Postclosure Monitoring and Maintenance Plan

30 Project Cost Estimates (Generally Prepared for In-House Use Only)

AA

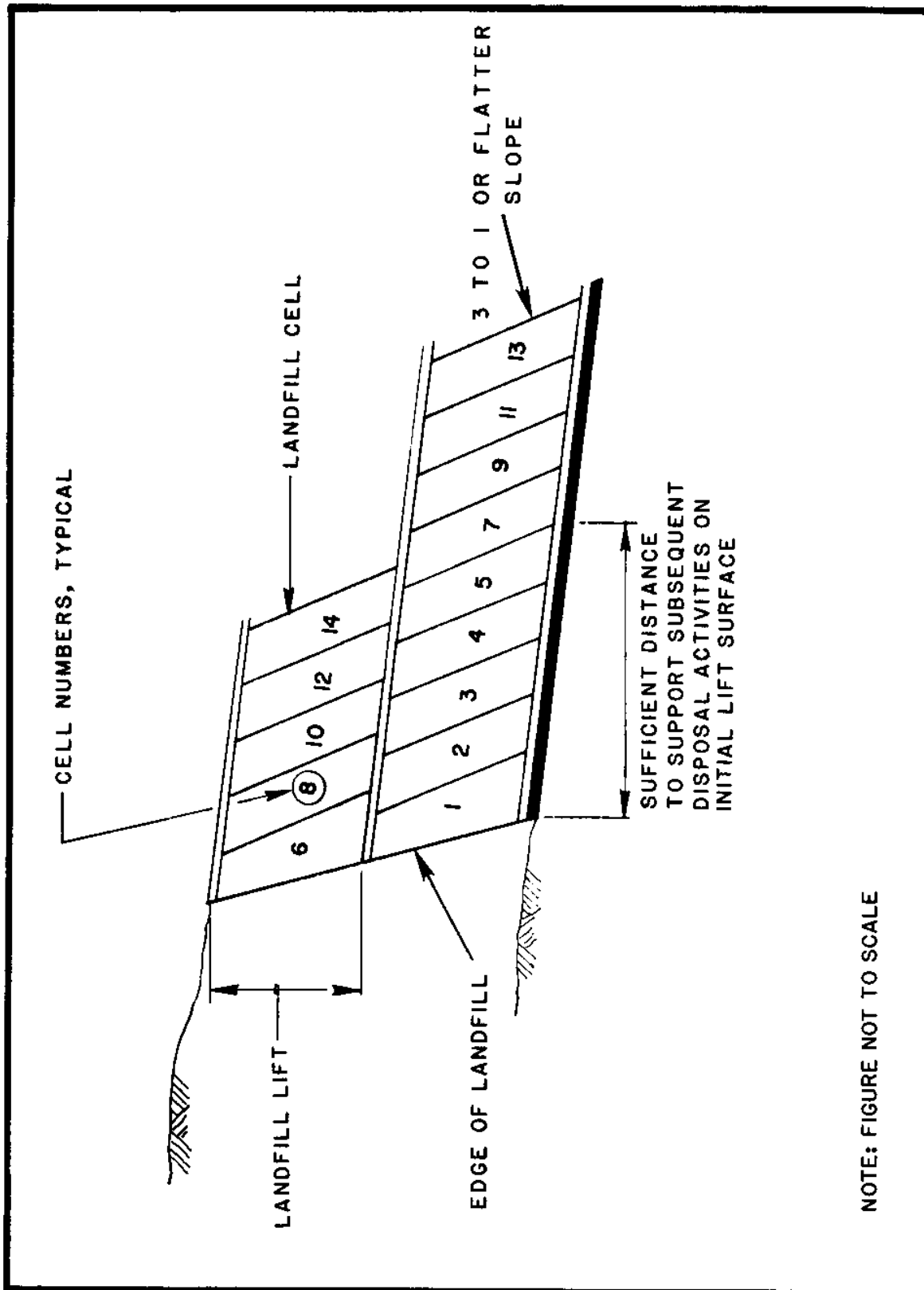

5.10-76

Figure 15  
Landfill Cell Lift Sequencing Diagram

A working face slope of 3 horizontal to 1 vertical will both minimize the surface area (and hence minimize the cover material volume) and aid in compacting the solid waste, particularly if the waste is deposited, then spread in layers not greater than about 3 feet (0.9 meters) thick and worked from the bottom of the slope towards the top.

7.4.4.1 Area Method. In this method, the waste is spread and compacted on the surface of the ground, and cover soil is spread and compacted over it (Figure 16). The area method is used on flat or gently sloping land and also in quarries, strip mines, ravines, valleys, canyons, or other land depressions. Cover soil is generally excavated from onsite sources as it is needed. This is an advantage over the trench method which requires that much of the cover soil be handled a minimum of two times, a more costly operation. Advantages and disadvantages of the area method are given in Table 20.

7.4.4.2 Trench Method. In this method, waste is spread and compacted in an excavated trench (Figure 17). Cover soil, which is taken from the excavation material, is spread and compacted over the waste to form the basic cell structure. Usually, cover soil is readily available as a result of the trench excavation. Excavated soil not needed for daily cover may be stockpiled and later used as a cover for a subsequent area fill operation on top of the completed trench fill.

In trench designs, the stability of the sidewall is critical. Sidewall stability, in turn, is determined by the characteristics of the soil, trench depth, distance between trenches, and slope of the sidewall. Clay, glacial till, and other fine grained, well-compacted soils permit maximum trench depths, and steep sidewall slopes. With coarser soils, flatter sidewall slopes are necessary to provide a more stable sidewall. Such conditions result in correspondingly lower waste volume capacities.

The trench can be as deep as soil and groundwater conditions safely allow. It should be as narrow as possible to reduce the amount of cover soil required. Its width is normally dictated by the number and type of vehicles using the site. Adequate dumping width must be maintained to allow space for delivery truck dumping and maneuverability. In any case, the trench should be at least twice as wide as any compacting equipment that will work in it. The equipment at the site may excavate the trench continuously at a rate geared to landfilling requirements. At small site excavation may be done periodically on a contract basis in advance of need.

A modification of the trench method involves initial excavation of a wide trench and subsequent operation perpendicular to the trench axis as an area fill. Soil for daily cover would be excavated from the trench "wall". As the filling progresses, cover soil excavations expand the area available for filling so that no new trenches need be excavated.

Advantages and disadvantages of the trench method are given in Table

7.4.5 Environmental Safeguards. Environmental factors that must be considered in sanitary landfill design (and operation) include those described below.

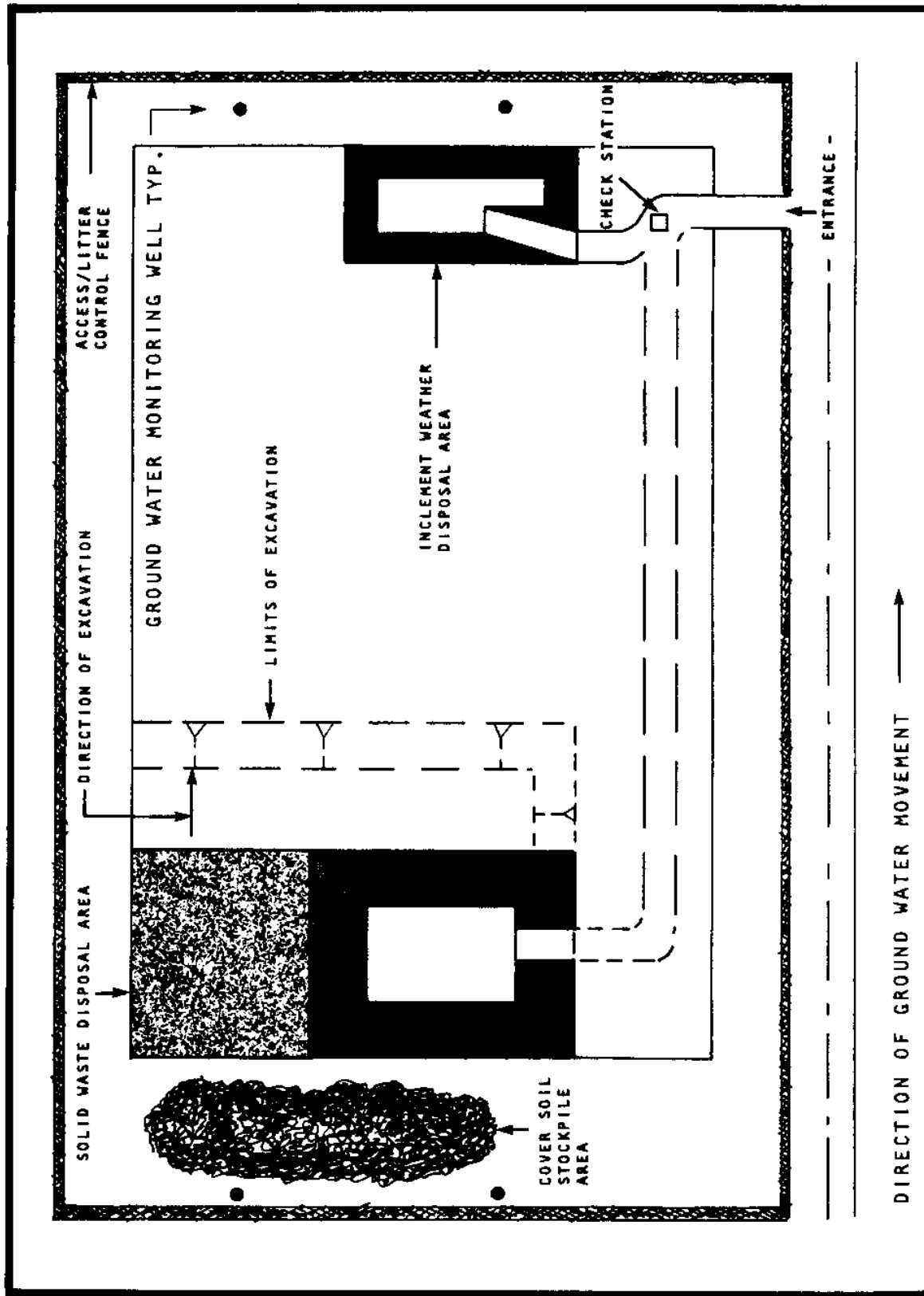
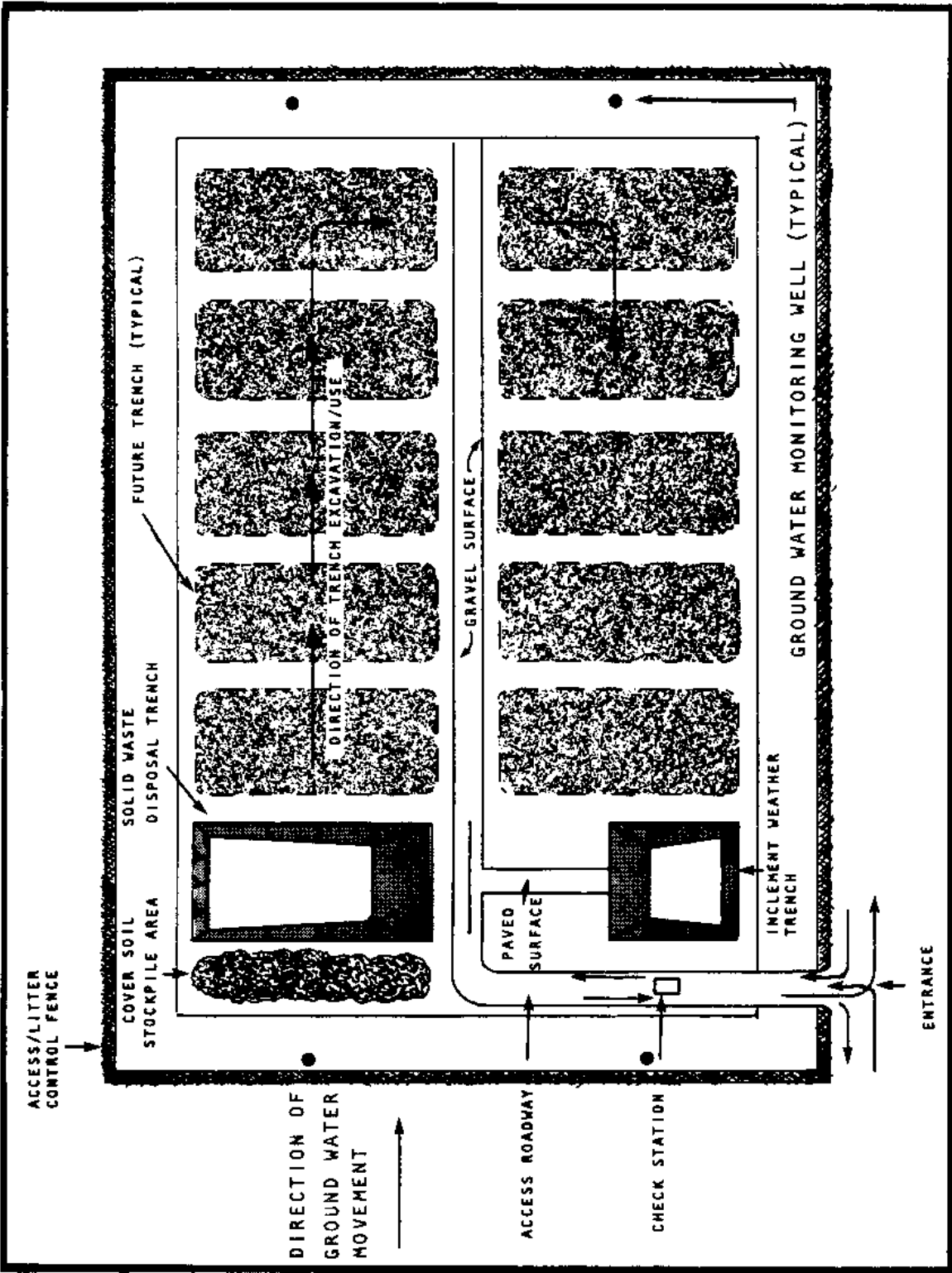

Figure 16  
Area method disposal Plan

Table 20  
Advantages and Disadvantages of the Area and Trench Method Landfilling Techniques

|               | Advantages  | Disadvantages   |
|---------------|---|---|
| Area Method   | <p>More of the site area and volume is available for waste disposal than in the trench method, since no barriers are required between trenches, nor are ramps needed for access into trenches.</p> <p>Traffic is easier to control; however, access for disposal vehicles can become a problem as the fill progresses upward unless onsite roads are carefully planned.</p> <p>Working area is easily expanded to accommodate varying volumes of waste.</p>   | <p>Litter is often more difficult to control than in the trench method, since more waste is exposed to wind.</p> <p>Drainage control may be more difficult due to steep slopes and rapid runoff.</p>  |
| Trench Method | <p>Good at low-volume disposal sites, since the exposed area of solid waste is minimized and confined in the trench.</p> <p>The sides of the trench are also the sides of the cell; excess soil can be stockpiled along each side of the trench to form a berm that helps to control blowing paper.</p> <p>More than one trench may be dug at a time. (Soil should be stockpiled for use as needed; while one trench is being filled, the adjacent trench is excavated and the excavated soil used for cover in the first.)</p> <p>Smaller sites may let contracts for excavation of several trenches in advance of need, thus allowing operation of landfill with lighter duty equipment than would be needed if excavation capabilities were also required.</p> | <p>Excavated trenches can fill up with precipitation; trench bottoms have to be properly graded and pumps used to prevent waste from contacting the accumulated water.</p> <p>Trench fills may require additional work effort, since the trench must first be excavated and then filled with solid waste. (About one half of the excavated soil must be handled twice.)</p> <p>Excess soil from trenches may have to be hauled off site.</p> <p>Usable soil is left in place as trench walls. This reduces volume of wastes that can be accepted at a given site.</p> |



5.10-80

Figure 17  
Trench Method Disposal Plan

7.4.5.1 Leachate Generation. Leachate is generated from moisture passing through the solid waste. It may be a result of moisture already present in the refuse, or from rainfall or irrigation infiltrating into and through the fill area. Regulations in most states require that sanitary landfills have facilities both to monitor for the presence of leachate and to control leachate that may otherwise adversely affect local water quality. There are presently no federal regulations concerning specific treatment or disposal methods for leachate generated at nonhazardous waste disposal sites. Some state agencies have implemented regulations governing leachate collection, treatment, and disposal methods. In addition, landfill leachate itself could be classified as a hazardous waste under RCRA, depending on chemical characteristics. Leachate that is classified as a hazardous waste would require treatment or disposal at a licensed hazardous waste facility.

A basic goal of a landfill design is to provide for features that minimize leachate production. In general, leachate generation can be minimized (or even eliminated in arid regions where evaporation significantly exceeds rainfall) by avoiding contact between waste material and groundwaters or surface waters; diverting offsite runoff away from the landfill; diverting onsite runoff away from active fill areas and minimizing runoff travel distances over filled surfaces; minimizing direct infiltration of precipitation into the fill by properly covering the solid waste with suitable soil or other material; and properly applying, compacting, and grading final soil cover (minimum 2- to 3-foot [0.6- to 0.9-meter] depth) when filling is completed in portions of the site.

Methods for mitigating adverse environmental effects of leachate include the use of a site that is hydrologically isolated from local aquifers or where natural conditions promote attenuation of leachate constituents via "filtering" through insitu soils, and the installation of a system to collect and subsequently treat the leachate generated before it contacts groundwaters or surface waters.

When natural conditions and contaminant attenuation through soils are proposed for mitigation of leachate impacts, the primary factors to be considered are the hydrogeological characteristics of the site, especially the hydraulic conductivity of the underlying strata, soil characteristics and the depth to usable groundwater. A soil that offers low permeability, high clay content, high cation exchange capacity (CEC), and relatively high pH (> 7.0) is preferred over soils composed of coarse-grained particles with high permeabilities and low CEC values.

The long-term effectiveness of contaminant removal via soil interaction processes is not verified, since the attenuating capacity of a soil is finite and not necessarily permanent. Further, if chemical loading rates exceed the soil's attenuative capacity, the quality of regional groundwater could be affected.

For site-specific information, subsurface investigations and soil tests should be performed onsite by qualified hydrogeologists and soil scientists.

Various leachate control and collection system designs are in use. Typically, a barrier of low-permeability soil or a flexible membrane liner is placed at the bottom of the site before initial placement of wastes to contain leachate that may percolate from above. The landfill bottom is prepared to accommodate the barrier, and is sloped to direct leachate to or more central collection sumps where it can be stored for subsequent onsite treatment or handling or be discharged to a sewer. Generally, leachate from solid waste is first channeled through a granular media (an often times perforated plastic collection pipes) placed atop the barrier liner layer. Figure 18 illustrates one design for a leachate collection system configuration.

Soil liners are usually constructed of clayey soils. These soils can often be obtained onsite, but imported clay minerals such as bentonite can also be used singularly or mixed with onsite soils if onsite soils are not suitable. If such soils are not available locally, the import by truck may be very expensive.

Flexible membrane liners can also be used in lieu of clay barriers. However, the long-term (>20-year) life of flexible membrane liners is not proven in a landfill environment, so a combination of clay and membrane liners are common. Manufacturers of synthetic polymeric liners (e.g., PV and chlorinated polyethylene) claim service lives from 15 to 30 years. However, a landfill may generate leachate for a significantly longer period. Table 21 presents a list of various materials used for landfill liners.

Collected leachate may be treated by one or more of the methods shown in Table 22.

Depending on the leachate characteristics, volume, and local regulations, it may be technically and economically practical to discharge untreated, collected leachate to an existing sewerage system for subsequent treatment along with municipal wastewater. The acceptability of disposal of leachate in this manner must be confirmed with local regulatory agencies.

If direct discharge to a sewerage system is not practical, onsite treatment or truck haul to a wastewater treatment plant or a hazardous waste facility are options.

**7.4.5.2 Landfill Gas.** Landfill gas (LFG) is produced by decomposition of the organic matter in solid waste. Immediately after solid waste is in place, and for several months thereafter decomposition occurs aerobically. The principal byproducts of aerobic decomposition are carbon dioxide gas and water. Once the free oxygen in the solid waste is depleted the decomposition process becomes anaerobic, and the principal byproducts are methane and carbon dioxide gases. Hydrogen sulfide, hydrogen, and some volatile organic gases are also sometimes generated. This methane-rich mixture of gases is called landfill gas.

The volume and composition of landfill gas produced depends on various factors, including the quantity and characteristics of solid waste deposited, the age of the landfill, and the amount of moisture present. Landfill gas is generated over an extended period. Landfill gas has been detected in landfills 75 years after site closure.

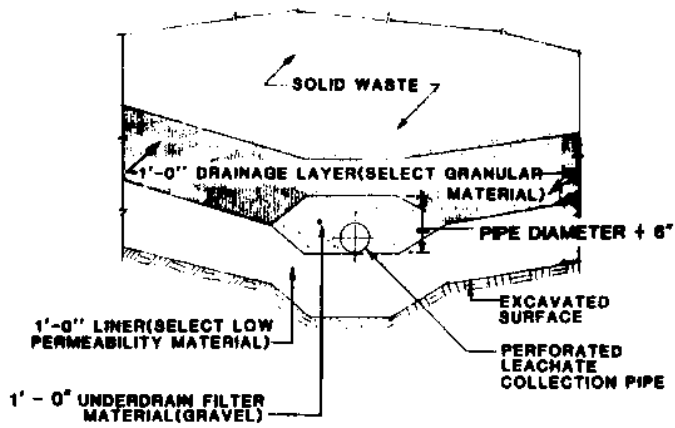

SECTION A-A

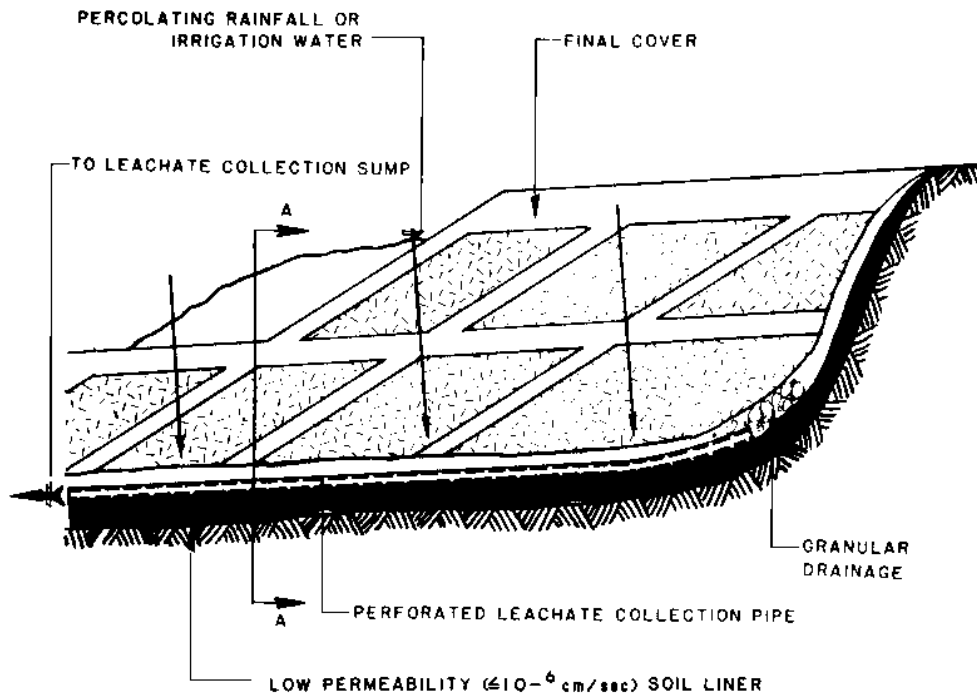

PLAN

**Figure 18**  
**Leachate Control System**

5.10-83

Table 21  
Materials Used for Landfill Liners

|  |  |   |
|--|--|---|
| UAAA |  |   |
| <sup>3</sup> o Asphalt compositions  |  | 3 |
| 3  |  | 3 |
| 3 - Asphaltic concrete   |  | 3 |
| 3 - Emulsified asphalt sprayed on soil or on fabric matting                |  | 3 |
| 3 - Soil asphalt mixtures  |  | 3 |
| 3 - Asphalt seals  |  | 3 |
| 3  |  | 3 |
| <sup>3</sup> o Portland cement compositions                                |  | 3 |
| 3  |  | 3 |
| 3 - Concrete with asphalt seals  |  | 3 |
| 3 - Soil cement with asphalt seals   |  | 3 |
| 3  |  | 3 |
| <sup>3</sup> o Soil sealants   |  | 3 |
| 3  |  | 3 |
| 3 - Chemical (soil amendments)   |  | 3 |
| 3 - Lime   |  | 3 |
| 3 - Rubber and plastic latexes   |  | 3 |
| 3 - Penetrating polymeric emulsions  |  | 3 |
| 3  |  | 3 |
| <sup>3</sup> o Liquid rubbers sprayed                                      |  | 3 |
| 3  |  | 3 |
| 3 - Rubber and plastic latexes   |  | 3 |
| 3 - Polyurethanes  |  | 3 |
| 3  |  | 3 |
| <sup>3</sup> o Synthetic polymeric membranes                               |  | 3 |
| 3  |  | 3 |
| 3 - Butyl rubber   |  | 3 |
| 3 - Ethylene propylene rubber (EPDM)                                       |  | 3 |
| 3 - Chlorosulfonated polyethylene  |  | 3 |
| 3 - Chlorinated polyethylene (CPE)   |  | 3 |
| 3 - Polyvinyl chloride (PVC)   |  | 3 |
| 3 - Polyethylene (PE)  |  | 3 |
| AAU  |  |   |

Table 22  
Leachate Treatment Methods

| Method  | Advantages  | Disadvantages   | Comments  |
|---|---|---|---|
| Discharge to a regional wastewater collection system or haul via truck directly to wastewater treatment plant or a licensed hazardous waste facility. | No onsite treatment required.   | Large volumes must be transported to be economically viable.  | Best method if distance to municipal wastewater treatment is small.   |
| Recycle through the landfill.   | Accelerated decomposition of the solid waste.<br>Reduction in the volume of leachate to be handled during dry periods due to evaporation.   | Odors.<br>Hazardous aerosols may be emitted and carried off by the wind.<br>Rainfall runoff may become contaminated.<br>Vegetation may be adversely affected.   | Normally an interim solution. Recycling is done via a subsurface pipe network or by spray irrigation.<br>Surface recycling is most appropriate in climates where evaporation rates exceed rainfall. In areas where the reverse is true, other leachate management systems may be needed in addition.  |
| Evaporation of leachate in collection ponds or impoundments.  | Low cost.<br>Does not affect ongoing landfill operations.   | Odors.<br>Large areas of land required.   | Evaporation ponds are most appropriate in climates where evaporation rates exceed rainfall. In some instances, it may be viable to channel leachate to evaporation ponds during the dry months of treatment during the rainy months.  |
| Onsite treatment in modular units for either biological or physical-chemical treatment.   | Depending on degree of treatment obtained, effluent may be discharged to nearby water courses.<br>Reduces possibility of shock loadings at sewage treatment plant if further treatment is required.<br>Does not affect ongoing landfill operations. | High cost.<br>Residual sludge may require disposal at a hazardous waste facility.<br>Requires skilled labor to operate and maintain.<br>May still require further treatment prior to discharge to water course. | Biological treatment generally consists of mechanical aeration for contaminant removal, including BOD reduction, odor control, and oxidation of iron, manganese, hydrogen sulfide, and various other contaminants.<br>Physical-chemical treatment processes are effective in treating leachate from landfills containing stabilized sludge or in removing organic matter from solid waste leachate.<br>Activated carbon and reverse osmosis is very expensive, and the viability of both processes on a large scale over extended periods as applied to leachate has not been verified. |

Methane, like carbon dioxide, is odorless. However, unlike carbon dioxide, methane is relatively insoluble in water. When methane is present in air in concentrations between 5 and 15 percent, it may be explosive. Methane can move both vertically and laterally from the landfill under a pressure gradient or a concentration gradient (diffusion). Generally, it vents into the atmosphere, where it is harmlessly dissipated. However, migrating landfill gas can seep into buildings, utilities, or other enclosed spaces, and create a hazardous condition. Migrating gas can also damage vegetation on the surface of a surrounding landfill by displacing oxygen from the root zone. The final landfill cover (e.g. soil, pavement, vegetation) can influence the extent of vertical and lateral landfill gas migration. Landfill gas is known to have migrated laterally several hundred feet from landfill sites.

In order to determine whether a potential hazard exists due to subsurface migration of LFG, a monitoring system is generally installed. A typical monitoring system consists of a series of monitoring wells constructed between the landfill and the area of concern (e.g., an inhabited structure). The wells are generally equipped with one to three monitoring probes for detecting LFG concentrations. Figure 19 shows a typical monitoring well configuration.

When monitoring wells indicate migration of potentially hazardous levels of methane gas (5 percent or greater), gas migration controls are required (RCRA requires that methane levels be maintained at 5 percent or less at the property boundary of the landfill, and less than 1.25 percent in any onsite structures.) Gas control techniques can generally be classified into two categories: passive or active methods. These methods are outlined in Table 23.

The various passive type LFG control systems commonly used are illustrated on Figures 20 and 21, Figure 22 illustrates a typical landfill gas extraction well configuration, and Figure 23 illustrates a forced air injection and landfill gas extraction system.

As shown on Figure 20, LFG interceptor trenches, barrier trenches, a combination of interceptor and barrier trenches are installed between the landfill and the structure(s) to be protected, or between the landfill and the property line if the structure is located offsite. Generally, trenches are installed as close to the structure(s) or property line as practical to be protected. Sufficient space should be left between the structure(s) or property line to allow for installation of monitoring wells to monitor trench effectiveness.

The spacing (D) of the air injection and gas extraction wells shown on Figure 23 is dependent upon several factors including:

- a) Landfill depth.
- b) Horizontal versus vertical soil permeabilities in which wells are placed.
- c) Distance between the landfill and structure(s) or property line to be protected.

Figure 24 provides an example calculation for determining injection and extraction well spacing in soil.

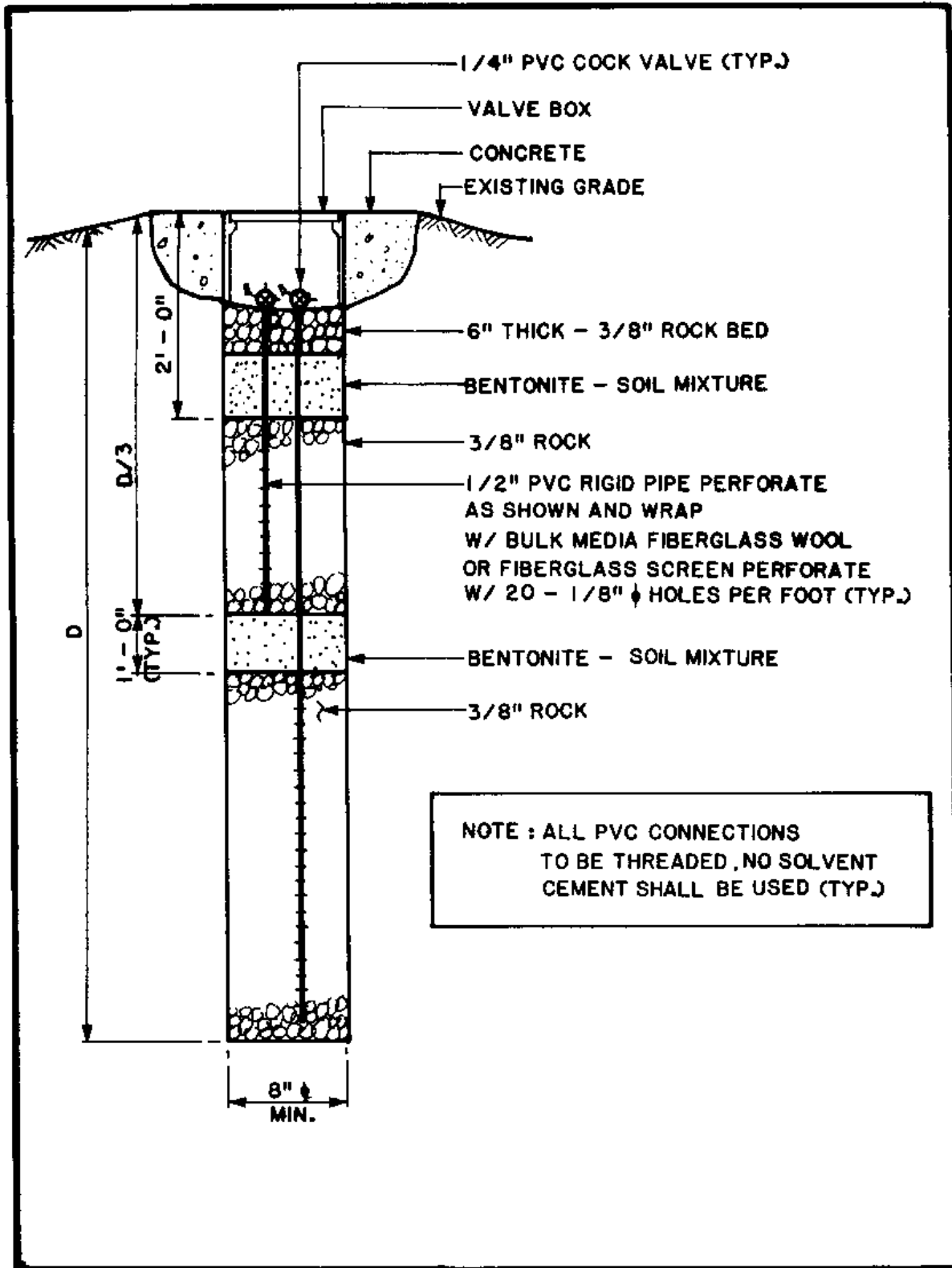
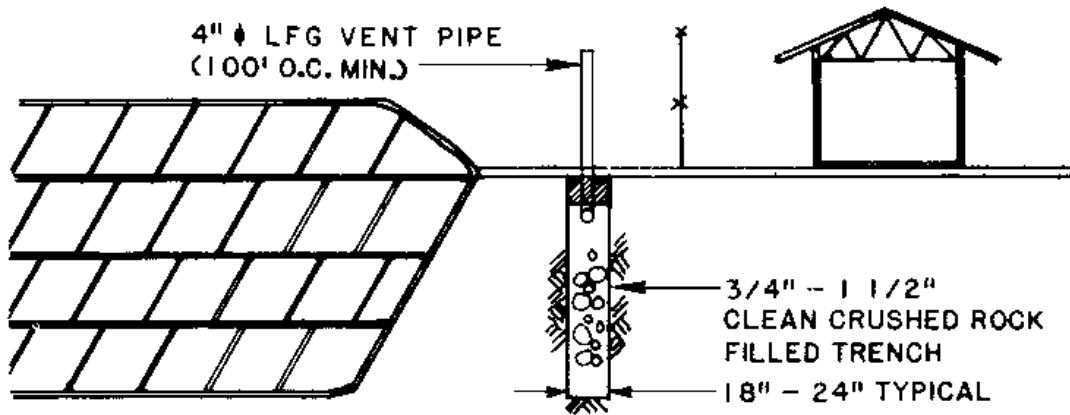

Figure 19  
Landfill Gas Monitoring Well

Table 23  
Control Techniques for Landfill Gas (LFG)

| Method   | Comments  |
|--|---|
| <b>PASSIVE SYSTEMS</b>   |   |
| Gravel-filled trenches or low-permeability barriers installed between the landfill and the area to be protected (see Figure 20). | Trenches and barrier effective they air a landfill or extend t groundwater surface.   |
| Synthetic membrane barriers installed beneath or within the building floor, slab (see Figure 21).                                | Membranes control ve migration into struc System most effectiv submembrane ventilat (e.g., a gravel laye vent pipes). Suffici must be provided to pressure buildup und  |
| Raised floor foundation with natural ventilation of the subfloor area.   | The number and size openings should be c (e.g., provide a saf   |
| A combination of the above.  |   |
| <b>ACTIVE SYSTEMS</b>  |   |
| Vacuum extraction (see Figures 22, 23, and 24).  | Systems draw LFG fro landfill or surround a central locati on v compressor where the flared or otherwise control odors. LFG the subsurface envir a well system or a g trench.   |
| Forced air injection (see Figures 22, 23, and 24).   | Systems are effectiv lateral LFG migratio injected into the so landfill via either gravel-filled trench "curtain" or barrier migration. Forced a also be used to flus subfloor and subslab of structures locate landfill sites. |



**GRAVEL FILLED LFG INTERCEPTOR TRENCH**

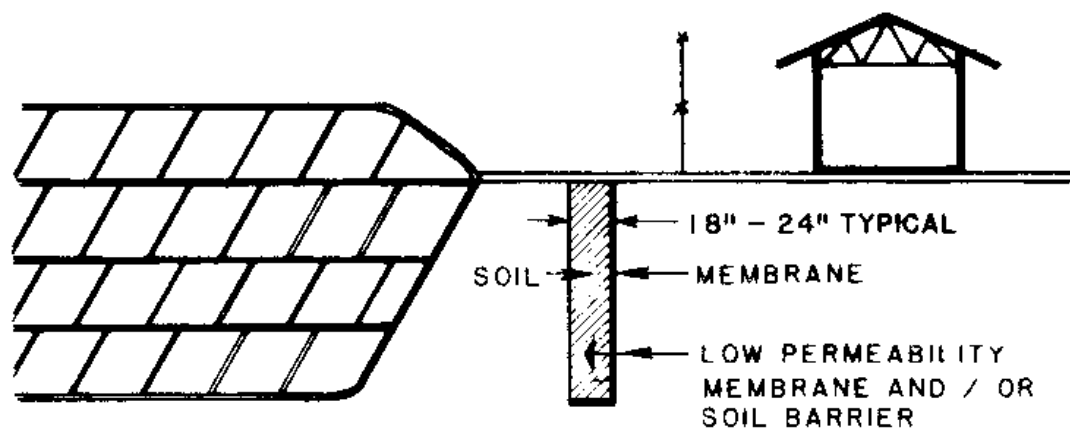

**LOW PERMEABILITY BARRIER LFG MIGRATION**

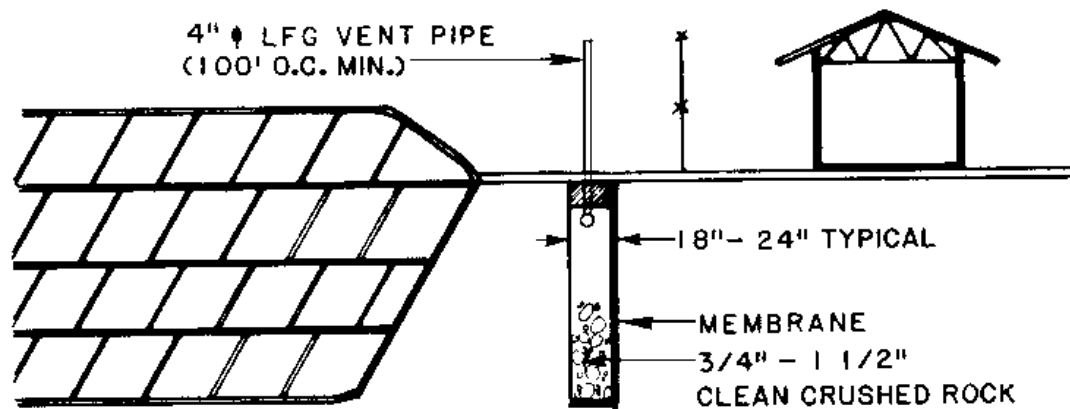

**COMBINATION INTERCEPTOR / BARRIER TRENCH**

Figure 20  
Passive Trench Landfill Gas Control System

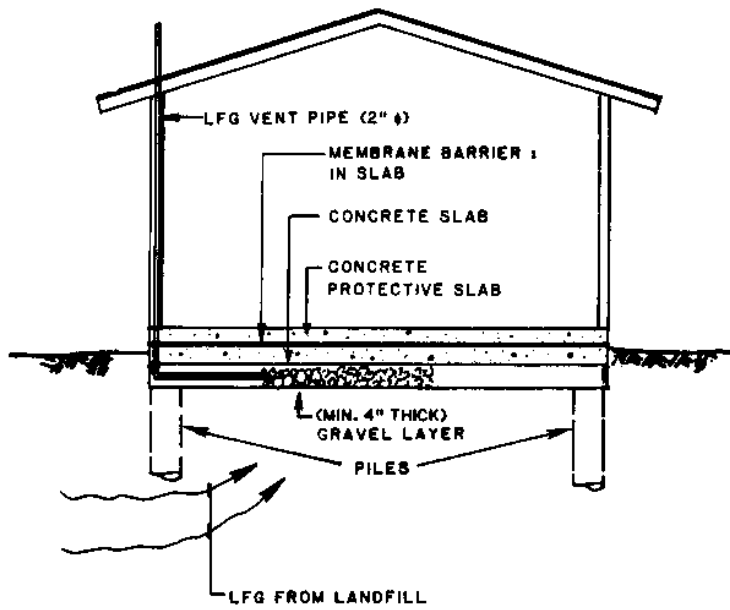

Typical Membrane Barrier System for Structure Built on Landfill

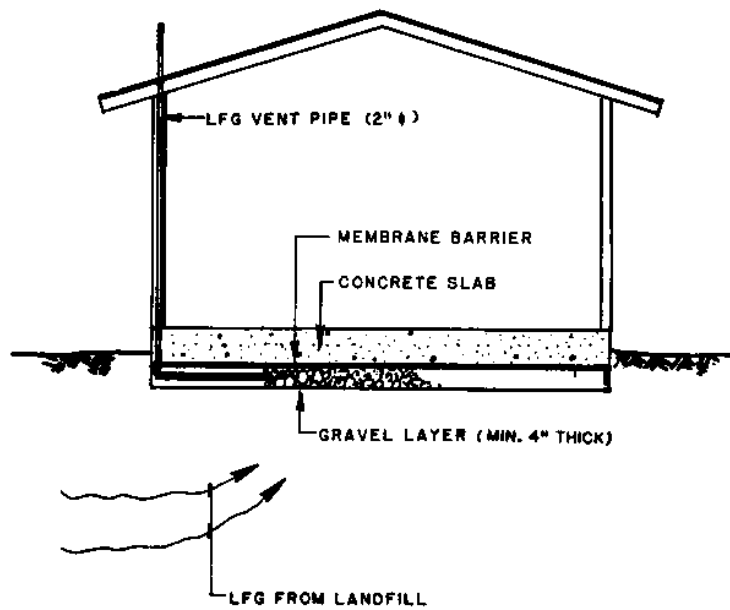

Typical Membrane Barrier System for Structure Built Adjacent Landfill

Figure 21  
Typical Membrane Barrier Systems

5.10-90

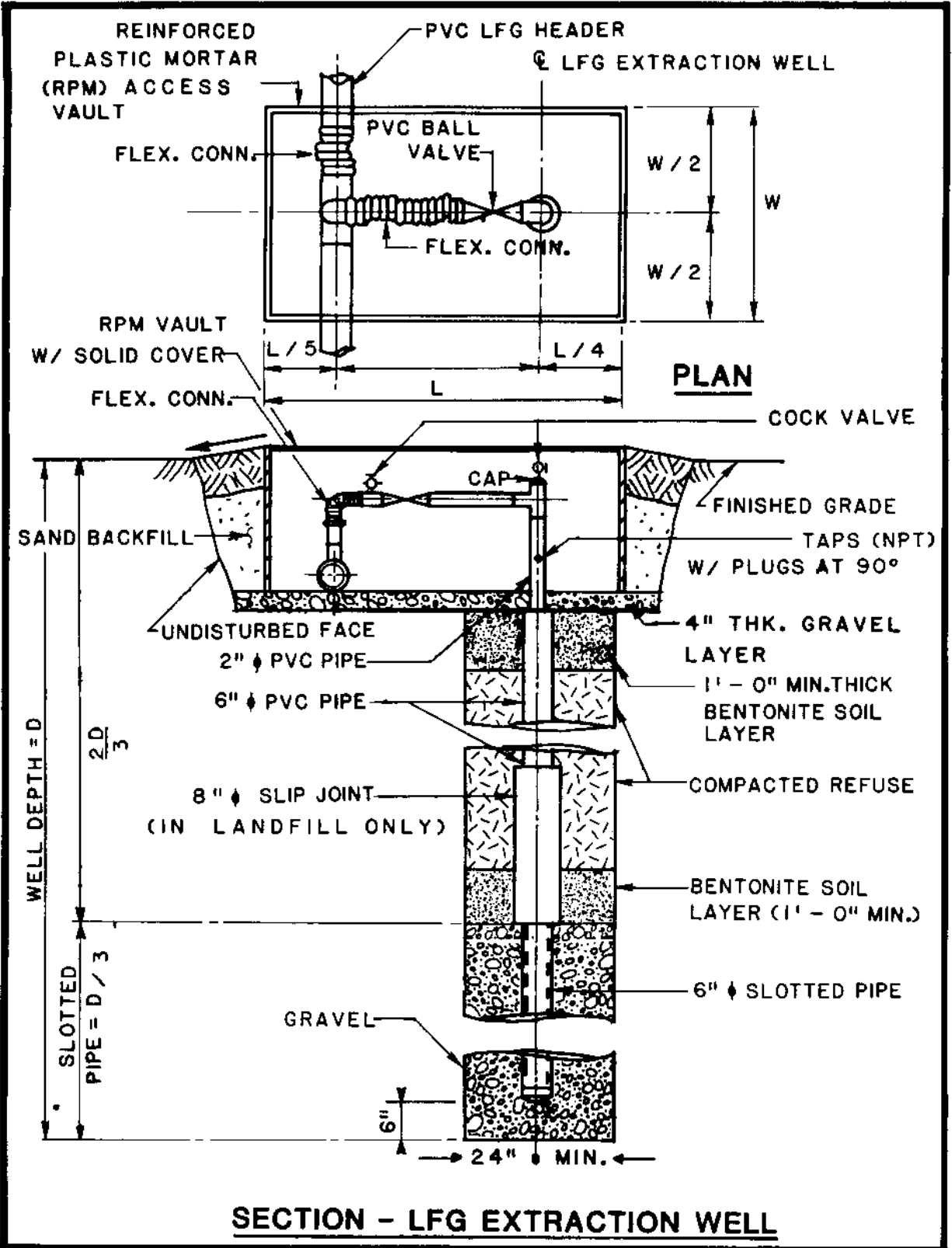

Figure 22  
Landfill Gas Extraction Well

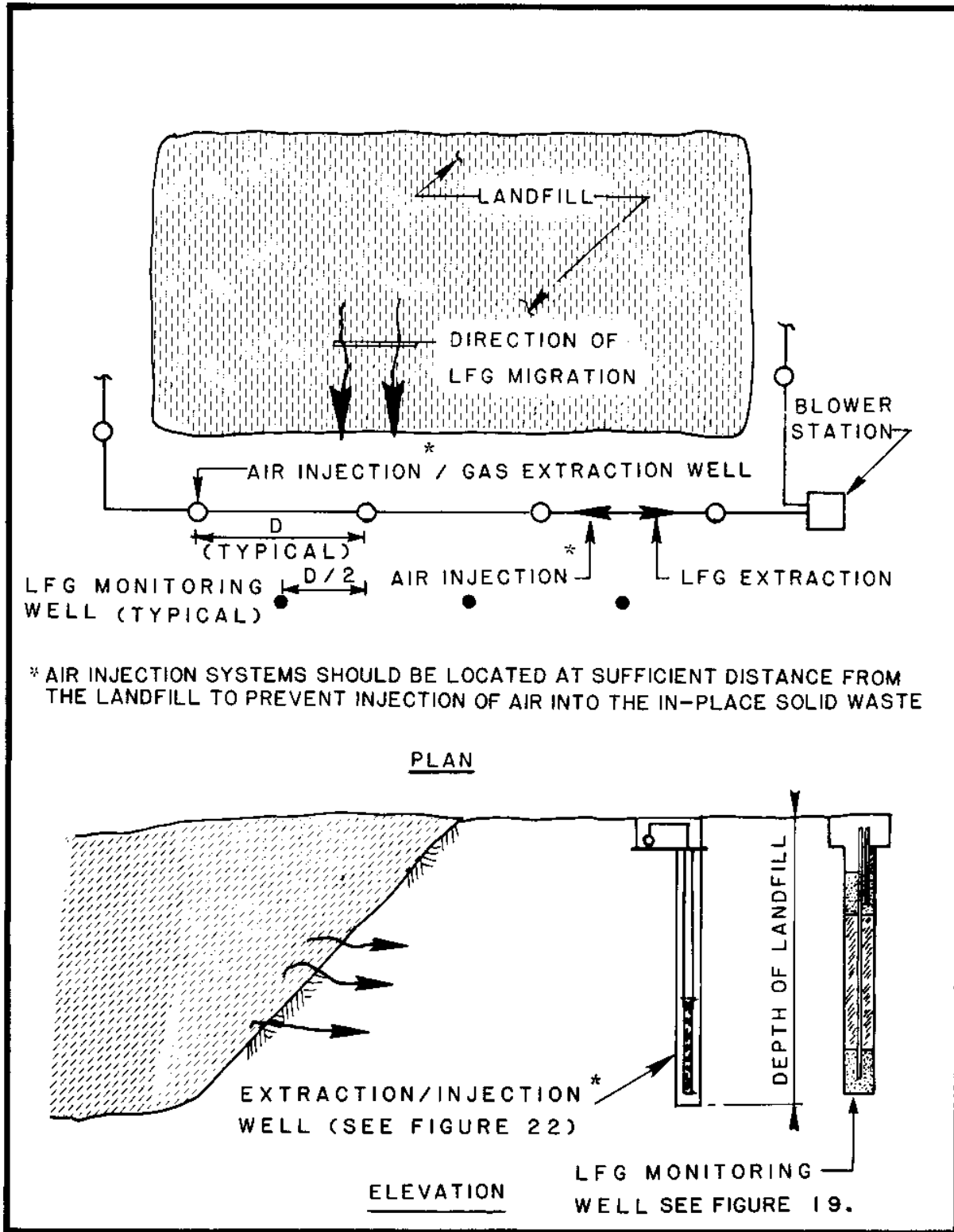

Figure 23  
Active Landfill Gas Control System - Outside of Landfill

Given:

- Landfill depth = 50 ft (15 m).
- Horizontal to vertical soil permeability ratio = 2/1.
- Distance from landfill to nearest structure = 100 ft (30 m).

Assume:

- Well depth = Landfill depth.
- Unperforated section of well casing = 2/3 of well depth = 33 ft (10 m).

Calculation:

- Radius of influence around each well = Depth of unperforated section of well casing x horizontal to vertical soil permeability ratio (2/1) = 33 ft (10 m) x 2/1 = 66 ft (20 m).
- Well spacing = 2 x radius of influence = 2 x 66 ft (20 m) = 132 ft (40 m).

Note:

The minimum distance from extraction wells to the landfill to minimize air injection into landfill (air injection system only) = Radius of influence of well. However, a safety factor of 25 percent or greater is recommended.

Thus, in this instance, the recommended distance from wells to landfill = 66 ft (20 m) x 1.25 = 82 ft (25 m)

This places the wells about 18 ft (6 m) from the nearest structure which is adequate to install monitoring wells for measuring injection/extraction well effectiveness.

Figure 24  
Example Calculation for Determining Injection/Extraction Well Spacing

Landfill gas recovery systems are similar to extraction type landfill gas control systems except that the objective is recovery of combustible gases rather than migration control. Recovery systems are designed to recover as much landfill gas as practical from the landfill while extract at a rate that does not introduce air into the landfill through the surface or sideslopes. Air kills the methane producing anaerobic bacteria and can inadvertently begin a fire in the fill. Typical landfill gas generation recovery rates for a landfill range from 0.04 to 0.15 cubic feet per pound (0.003 to 0.009 cubic meters per kilogram) per year.

Extracted landfill gas can be used as recovered with some minor processing (e.g., moisture dropout) for use as a medium-Btu (e.g., 500 Btu per cubic foot [18 620 kilojoule per cubic meter]) boiler fuel or for powering a gas turbine or internal combustion engine to generate electricity. Recovered landfill gas can also be upgraded to pipeline quality gas (i.e., 1,000 Btu per cubic foot [37 245 kilojoule per cubic meter]) by various methods for introduction into the natural gas distribution system. The upgrading of recovered landfill gas to pipeline quality gas is very capital-intensive and would not generally be practical for construction of a Navy installation.

7.4.5.3 Odors. Odors originate from the waste as it is delivered; from decomposing waste in place at the landfill; and from leachate seeps, pond and treatment systems. Odors from refuse can usually be mitigated by applying cover rapidly and ensuring that the cover is maintained intact.

7.4.5.4 Noise. Noise sources at landfills include operating equipment and haul vehicles. Generally, the noise is similar to that generated by any heavy construction activity, and is confined to the site and the streets used to bring solid waste to the site. To minimize the effect, every effort should be made to route traffic through the least populated areas. Further, the site can be isolated so that the noise cannot carry to nearby neighborhoods. The use of earthen berms and trees as noise barriers can be very effective. On the site, noise protection for employees will be governed by existing Occupational Safety and Health Act (OSHA) standard, CFR 1910.95, Occupational Noise Exposure.

7.4.5.5 Air Pollution. The two sources of air pollution (other than from odor and dust) are from the equipment working on the site and from vehicles bringing refuse to the site. Proper control of equipment emissions should minimize any potential air pollution sources.

7.4.5.6 Fires. Fires in landfills can result from the unknowing disposal of a hot load, sparks from vehicles, or deliberate ignition. The latter is prohibited at a well-run sanitary landfill. Hot loads can be minimized by proper policing of incoming trucks; these loads should be deposited away from the working face and immediately extinguished by water or covering with soil. Adequate daily soil cover and cover between cells are helpful in preventing and controlling fires by providing natural barriers.

7.4.5.7 Vectors. Vectors at landfills include flies, mosquitos, and rodents. Flies can be best controlled by placing adequate compacted cover soil as frequently as possible. Studies have shown that a daily cover consisting of 6 inches (150 millimeters) of compacted low-clay content soil will prevent fly emergence. However, even under the best of conditions, landfill should have a regular inspection and fly control program. Mosquito control is best accomplished by preventing development of stagnant water bodies anywhere on the site. Continuous grading to fill low spots is essential.

Occasionally, rats and mice are delivered to the site along with the solid waste. If harborage is available adjacent to the site or in some neglected area of the site, extermination will become necessary. This is best conducted by the local health department or an experienced commercial exterminator. Employees should be trained to recognize burrows and other signs so that control can be accomplished before a problem arises.

7.4.5.8 Storm Water Management. All upland drainage should be diverted around the landfill. Drainage may be channeled under the landfill via an enclosed pipe, but only if absolutely necessary. The drainage channels may be constructed of earth, corrugated metal pipe (CMP), sodded gunite-swales, and stone-lined swales. If the access or onsite roads of the landfill are paved, they may be used to channel drainage across a landfill. Drainage structure sizing should be based on hydrology studies and hydraulic design for the specific site. Design storm frequency selection should be consistent with state or local ordinances and calculation procedures.

On the landfill itself, all active and completed site working areas should be properly graded. The surface grade should be greater than 2 percent to promote runoff and inhibit ponding of precipitation, but less than 5 percent to reduce flow velocities and minimize soil erosion. If necessary, siltation ponds should be constructed to settle the solids contained in the runoff from the site. Straw bales, berms, and vegetation may supplement ponds or be used in conjunction with them to control runoff velocities and siltation on the site. Since the location of active fill areas are constantly changing, portable drainage structures may be more economical than permanent facilities in some instances.

7.4.5.9 Access Roads. As a minimum, a paved onsite road should be provided from the public road system to the site. The onsite roadway should be 20 to 24 feet (6 to 7 meters) wide for two-way traffic. For smaller operations 15 feet (5 meters) wide road can suffice. As a minimum, the roadway should be gravel-surfaced in order to provide access regardless of weather conditions. Grades should not exceed equipment limitations. For loaded vehicles, most uphill grades should be less than 7 percent and downhill grades less than 10 percent.

Temporary roads are used to deliver the solid waste to the working area from the permanent road system. Temporary roads may be constructed by compacting the natural soil present and by controlling drainage, or by topping them with a layer of gravel, crushed stone, cinders, crushed concrete, mortar, bricks, lime, cement, or asphalt binders to make the roads more serviceable.

7.4.6 Soil Availability. The estimated quantity and adequacy of onsite soil for use as cover soil will have been determined during the site selection process. The logistics of soil excavation, stockpiling, and placement should be more thoroughly evaluated during design. Excavation stockpiling of soil should be closely coordinated with soil use for the following reasons:

a) Soil determined to be readily excavatable and suitable for use as cover may be located in only certain areas of the site. The excavator should designate that soil be removed from these areas before filling has proceeded atop them.

b) Accelerated excavating programs may be desirable during warm weather to avoid the need to excavate frozen soil during cold weather.

c) Soil stockpiles should be located out of the way of haul vehicles using the landfill, but convenient for daily placement of cover. This consideration is critical in order to avoid unnecessary material handling and to maintain a clean site.

d) Soil stockpiles should be laid out and maintained to minimize erosion from rainfall runoff.

e) Stockpiling of soil atop already filled areas can accelerate settlement, thereby increasing site capacity.

7.4.7 Special Working Areas. Special working areas should be designated the site plan for inclement weather (e.g., wet weather), special wastes, other contingency situations. Access roads to these areas should be of all-weather construction and the area kept grubbed and graded. Arrangements for special working areas may include locating such areas closer to the landfill entrance gate. If private vehicles deliver waste, an onsite transfer station or solid waste bin can be maintained to reduce passenger car and truck traffic conflicts.

In addition to being readily accessible, areas for disposal in inclement weather should be constructed to allow unhindered refuse disposal. Vehicles should not become mired in a muddy surface. All rainfall runoff should be diverted around or away from these areas. They should either be constructed on natural ground or over refuse which has been in place for preferably one year, and which is covered with a compacted soil layer a minimum of 2 feet (0.6 meter) thick. In either case, a final, low moisture-penetrating, hardened surface (such as crushed rock or crushed concrete) should be placed atop the inclement weather area.

7.4.8 Buildings and Structures. Buildings and structures typically provided at landfill sites include:

- a) Office.
- b) Employee facilities (e.g., lunchroom, showers, sanitary facilities).
- c) Equipment storage and maintenance.

Buildings on sites that will be used for less than 10 years can be temporary, mobile structures. If possible, structures or buildings should be located on natural ground a sufficient distance from the landfill to preclude hazard from subsurface LFG migration. A good rule of thumb is a minimum distance of 1000 feet (310 meters) from the landfilling area. However, a greater distance may be required if the subsurface soils are highly permeable and upward migration of LFG to atmosphere through the surface is impeded by vegetation or pavement. If this is impractical, the design and location of all structures should consider gas movement and, if located over refuse, the differential settlement caused by decomposing so waste.

7.4.9 Aesthetics. Maintaining a satisfactory appearance at the landfill is an effective means of promoting good relations and ensuring user cooperation in landfill operations. When clearing the area, trees and bushes can be left at or transplanted to the perimeter of the site to provide screening and buffering. The entrance and weigh station should be attractive, as should other facilities. Completed areas should be landscaped as soon as possible after completion.

7.4.10 Scales. Recording the weights of solid waste delivered to a site can help regulate the landfill operation as well as the solid waste collection system that serves it.

Scales range from simple, separate axle-loading scales to sophisticated electronic scales that feature printed outputs. Usually a portable scale is sufficient for small operations with a limited site life.

Alternatively, smaller sites may elect to use a portable scale once a year for a week or so to record "typical" waste quantities.

The platform and scale should be compatible with the trucks and loads that are routinely handled at the site. In most cases, a platform between 10 and 35 feet (3 to 11 meters) will be sufficient for collection vehicle and one of 50 feet (15 meters) will handle most trucks with trailers. A scale that records up to 35 tons (31 800 kilograms) should be adequate for most landfills.

7.4.11 Utilities. Larger landfills should have electrical, water, communication, and sanitary services. Remote sites may have to extend existing services or use acceptable substitutes. Portable chemical toilets can be used to avoid the high cost of extending sewer lines; potable water may be trucked in; and an electric generator may be used instead of having power lines run into the site.

Water should be available for drinking, dust control, washing mud from haul vehicles before entering the public road, employee sanitary facilities and fire control. A sewer line may be desirable, especially at large sites for conveying leachate to the domestic wastewater treatment plant.

Telephone or radio communications may be necessary since accidents can occur that necessitate the ability to respond to calls for assistance.

7.4.12 Fencing. Access to landfills should be limited to one or two entrances that have gates that can be locked when the site is unattended. Depending on the topography and vegetation on the site and adjoining area entrance gates may suffice to prevent unauthorized vehicular access. At some sites it is desirable to construct periphery fences to keep out any trespassers and animals.

Fencing requirements will be greatly influenced by the relative isolation of the site. Sites close to housing developments may require fencing to keep out children and to provide a visual screen for the landfill. Landfills that are in relatively isolated areas or a shore installation may require a less expensive fence or only fencing at the entrance and other places to keep out unauthorized vehicles.

If vandalism and trespassing are to be discouraged, a 6-foot (1.8-meter) high chain link fence is desirable (although expensive). A wood fence or a hedge may be used to screen the operation from view. A 4-foot (1.2-meter) high barbed wire fence will keep cattle or sheep off the site.

Portable fencing at the working face will help contain wind-blown litter. For trench operations, a 4-foot (1.2-meter) fence will usually be adequate, but 6 to 10 feet (1.8 to 3 meters) or higher litter fences may be necessary in area operations. Specially designed portable litter fences are available that are easily moved across the working face.

7.4.13 Lighting. If disposal operations occur at night, portable lighting should be provided at the operating area. Alternatively, lights may be affixed to haul vehicles and onsite equipment. These lights should be situated to provide illumination to areas not covered by the regular headlights of the vehicle.

If the landfill has structures (employee facilities, administrative offices, equipment repair or storage sheds, etc.), or if there is an access road in continuous use, permanent security lighting might be desirable.

7.4.14 Wash Rack. To prevent trucks from carrying litter and mud on surrounding roadways, the design plans should include a washrack. This is particularly true in large sites, in wet climates where the soil is heavy and for sites near residential or commercial areas.

7.4.15 Landscaping. Landscaping for the site should be selected based on the following criteria:

- a) Proposed interim and end uses.
- b) Degree of tolerance to adverse soil conditions (e.g., concentrations of landfill gas in the soil interstices).
- c) Depth of root zone.
- d) Amount of water required to sustain growth.
- e) Final landfill configuration.
- f) Ability to control erosion.

Table 24 lists several trees and grasses that have proven to be tolerant to conditions at sanitary landfills.



## 7.5 Equipment.

7.5.1 Introduction. Equipment at solid waste landfills should be selected in relation to the following parameters:

- a) Waste quantities and types to be handled, including peak waste quantities and projected future waste quantities.
- b) Daily and seasonal variations.
- c) Soil excavation, haul, and cover application, including type and quantity of onsite soils and haul distance.
- d) Time requirement for waste covering and soil compaction.
- e) Site conditions, including clearing and grubbing requirements, topography, and climate.
- f) Auxiliary functions, including road construction and maintenance, construction and maintenance of drainage facilities, assistance with vehicle unloading, and movement of other materials or equipment at the site.
- g) Standby or backup equipment needs.
- h) Maintenance requirements, including maintenance history and record at other sites, and availability of parts or of manufacturers' local skilled maintenance personnel.
- i) Operator comfort.
- j) Costs.

7.5.2 Equipment Types and Characteristics. Figure 25 illustrates the major types of earthmoving and compaction equipment commonly found in landfill sites. In general, sanitary landfills sized for Navy shore installations would require one or two of the equipment units discussed below.

7.5.2.1 Track Machines. As a result of their versatility, track machines are one of the most commonly used machines at solid waste landfills. There are two types: dozers and loaders. Other common names for them are bulldozers, crawler dozers, track dozers, track loaders, crawler loaders, front-end loaders, and bullclams; trade names are also used. They all have good flotation and traction capabilities because their self-laying tracks provide large ground contact areas. Track machines are excellent for excavation work and moving over unstable surfaces, but they can only operate at about 3 to 4 miles (5 to 6 kilometers) per hour, in forward or reverse.

The track dozer is excellent for grading and can be economically used for spreading waste or earth over distances of up to 300 feet (91 meters). It is usually fitted with a straight dozer blade for earthwork; however, for solid waste, it should be equipped with a U-shaped blade that has been fitted with a top extension (trash or landfill blade) to push more solid waste.

Waste densities achieved with a track dozer generally range from 800 to 1,000 pounds per cubic yard (475 to 600 kilograms per cubic meter) or greater, depending on the solid waste composition and skill of the operator. The track loader is able to spread less solid waste than the track dozer; however, the track loader is an excellent excavator and can carry soil (economically) as much as 300 feet (91 meters).

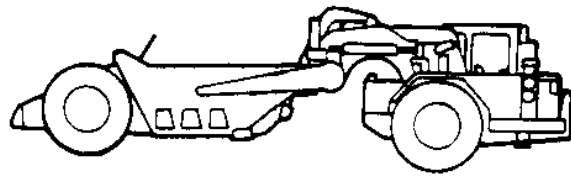

SELF PROPELLED SCRAPER

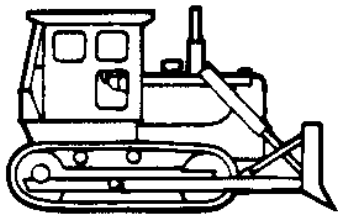

TRACK DOZER

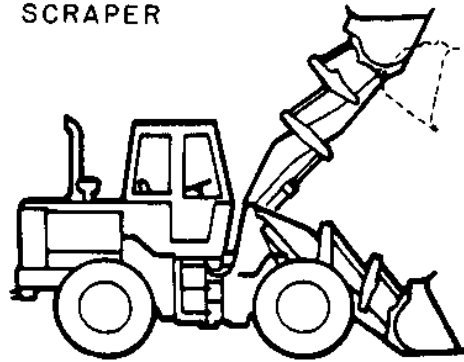

WHEEL LOADER

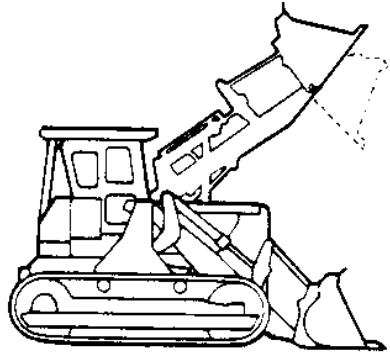

TRACK LOADER

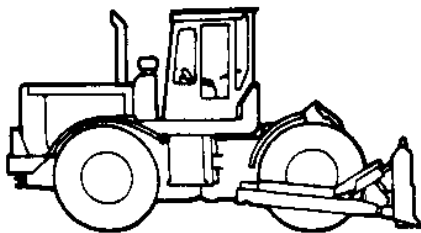

WHEEL DOZER

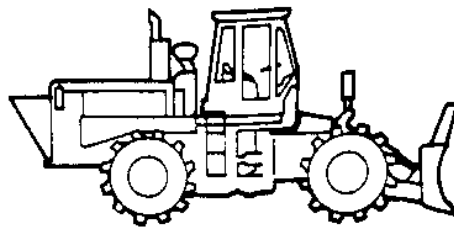

LANDFILL COMPACTOR

Figure 25  
Landfill Earthmoving/Compaction Equipment

7.5.2.2 Rubber-Tired Machines. Both dozers and loaders are available with rubber-tired wheels. Rubber-tired machines are not generally used at solid waste landfills, since operating conditions can cause tire punctures. Moreover, the rough spongy surfaces at landfills, combined with reduced traction and flotation, limit the effectiveness of rubber-tired machines spreading wastes, grading, and excavating.

Because of its high operating speed, up to 29 miles (47 kilometers) per hour on solid ground, the rubber-tired loader is suited for carrying cover material economically over distances of up to 600 feet (180 meters), and putting cover material into haul trucks. Rubber-tired machines used extensively on landfills should be equipped with steel-guarded tires (rock tires). Alternatively, tires can be filled with foam to reduce the frequency of punctures. Solid waste compaction densities of 900 to 1,100 pounds per cubic yard (530 to 650 kilograms per cubic meter) can be obtained using a wheel loader.

7.5.2.3 Landfill Compactors. Several equipment manufacturers market landfill compactors equipped with large trash blades. In general, these machines are modifications of road compactors and log skidders. The power train and structure of landfill compactors are similar to those of rubber-tired machines, and their major asset is their steel wheels. The wheels are either rubber tires sheathed in steel or hollow steel cores. Both types are studded with load concentrators. Rubber-tired dozers and loaders have also been modified for use as landfill compactors.

Steel-wheeled landfill compactors impart greater crushing and compact effort than do rubber-tired or crawler machines. A large landfill compactor can reportedly produce in-place solid waste densities of 1,200 to 1,600 pounds per cubic yard (710 to 950 kilograms per cubic meter).

The landfill compactor is an excellent machine for spreading and compacting on flat or level surfaces and operates fairly well on moderate slopes, but it lacks traction when operating on steep slopes or when excavating. For this reason, landfill compactors are best used for spreading and compacting solid waste and cover material, and an additional piece of equipment will be required for soil excavation, hauling, and spreading. If the cover material is clay, it may become lodged between the load concentrators (together with solid waste). When this occurs, the concentrators must be continually scraped with cleaner bars.

7.5.2.4 Scrapers. Scrapers are excellent for earthmoving and excavation. Scrapers are also effective in applying interim and final cover. Because their tires are susceptible to punctures on landfills, and because of the low clearance, they are not well suited for applying cover directly over waste. However, they are useful for applying cover over daily and interim soil layers. There are three types of scrapers: nonmechanized pulled scrapers, self-propelled scrapers, and self-loading elevating scrapers.

Pulled scrapers require the use of a track dozer for excavation and hauling operations. They are most appropriate for use on small landfills. Although pull scrapers are low-production machines, they are inexpensive purchase and maintain.

Self-propelled and self-loading elevating scrapers are particularly useful in Sites that require extensive soil stockpiling and handling. They can economically haul cover soil over distances in excess of 1,000 feet (meters). Hauling capacities range from 9 cubic yards (7 cubic meters) to just over 50 cubic yards (38 cubic meters).

Because self-propelled scrapers are costly to purchase, smaller sites should investigate leasing, renting, borrowing, or contracting arrangements before purchasing. For example, a single scraper, operating for a month less, could excavate and stockpile enough soil for an entire year for small landfills.

7.5.2.5 Draglines. The dragline is an excellent excavating machine. However, since the unit cost of excavating soil with a dragline is higher than that of scrapers, its use is usually limited to sites with high rainfall or wet soils, where its ability to excavate soils while based in one location enables it to operate effectively. The dragline is most commonly found at large landfills where the trench method is used or where cover material is obtained from a borrow pit. As a rule of thumb, the boom length should be two times the trench width. Buckets used at landfills usually range from 1 to 3 cubic yards (0.8 to 2.3 cubic meters)

7.5.3 Equipment Selection. No one machine is capable of performing all functions equally well. However, for the majority (if not all) Naval base landfills, one piece of equipment (e.g., a track loader) could suffice as the only piece of full-time equipment required for landfilling operations. Guides that have been proposed by equipment manufacturers and others should be considered only rough estimates of equipment needs for a particular landfill (see Table 25).

7.6 Closure and Postclosure. A sanitary landfill should be closed in accordance with the design plan prepared for the site. Prior to closure, it is expeditious to have determined the site's end use. A discussion of possible end uses is given in Table 26.

Once the site closure plan has been approved and the site closed in accordance with that plan, the postclosure monitoring and maintenance program will then begin. Closure and postclosure monitoring activities include:

- a) Bringing all areas of the site surface to final grade.
- b) Application of final cover soil. The minimum depth of final cover should be 2 feet (0.6 meter). To cut down on water infiltration, additional cover thickness or a specialized cover configuration (see Figure 26 derived from California Water Regulations, subchapter 15, Waste Disposal to Land) may be required. Also, site areas landscaped with deep rooted plants will require greater soil depths, perhaps up to 5 or 6 feet (1.5 to 1.8 meters).
- c) Construction of all permanent drainage facilities.
- d) Completion of site landscaping for aesthetics and dust and erosion control.
- e) Installation of permanent leachate and gas control or recovery facilities that may not have previously been installed.

Table 25  
Waste Handling and Compaction  
Equipment Sizing Table[\*]

| UAA |            |                   |                 |               |     |
|---|------------|-------------------|-----------------|---------------|-----|
| 3   | Handled    | Equipment         | Track-Type      | Track-Type    | Whe |
| 3   | (Tons/8    | Characteristics   | Tractor         | Loader        | Co  |
| 3   | Hours) [+] |                   |                 |               |     |
| 3AA |            |                   |                 |               |     |
| 3   | Up to 40   | Horsepower        | 75 - 80         | 75 - 80       |     |
| 3   |            | Wt. (kips) [#]    | 16 - 20         | 21 - 25       |     |
| 3   |            | Blade (ft) [**]   | 8 - 10-1/2      |               |     |
| 3   |            | Bucket (yd³) [++] |                 | 1-1/4 - 1-1/2 |     |
| 3   | 25 - 90    | Horsepower        | 105 - 140       | 95 - 130      | 15  |
| 3   |            | Wt. (kips)        | 26 - 32         | 27 - 33       | 3   |
| 3   |            | Blade (ft)        | 10-1/4 - 12     |               |     |
| 3   |            | Bucket (yd³)      |                 | 1-3/4 - 2     |     |
| 3   | 60 - 180   | Horsepower        | 140 - 150       | 130 - 145     | 15  |
| 3   |            | Wt. (kips)        | 30 - 32         | 32 - 34       | 3   |
| 3   |            | Blade (ft)        | 10-1/4 - 12-3/4 |               | 1   |
| 3   |            | Bucket (yd³)      |                 | 1-3/4 - 2-1/4 |     |
| 3   | 125 - 225  | Horsepower        | 150 - 190       | 190 - 200     | 17  |
| 3   |            | Wt. (kips)        | 41 - 49         | 48 - 50       | 3   |
| 3   |            | Blade (ft)        | 11-1/2 - 14-1/4 |               | 1   |
| 3   |            | Bucket (yd³)      |                 | 2-1/2 - 3-1/4 |     |
| AA  |            |                   |                 |               |     |

[\*] Based on ability of one machine in stated class to spread, compact, within 300 ft (92 meters) of working face.

[+] 1 ton/8 hours = 0.90718 metric tons/8 hours.

[#] 1 kip = 453.6 kg.

[\*\*] 1 ft = 0.305 m.

[++] 1 yd³ = 0.7646 m³.

Table 26  
End Uses for Landfill Sites

| End Use   | Comments   |
|---|--|
| Recreation  | Major problems encountered include damaged landscaping due to landfill gas settlement (generally only a major problem in ball fields or other developed areas); broken water irrigation lines due to differential settlement.  |
| - Golf courses  |  |
| - Parks and Play areas, including ball diamonds                   |  |
| - Archery ranges  |  |
| - Open space with passive recreation; walking, bird walking, etc. |  |
| Commercial and Light Industrial Development                       | Typically, the structures are placed on piles to Protect against different settlements. Although some small buil (10 feet x 15 feet [3 meters x 5 mete have been constructed using floating foundations. Significant maintenance required in both cases: landfill grad adjacent to buildings on piles requir almost continuous raising due to sett and areas adjacent to buildings place floating slabs require periodic level and adjustment of surface grades due differential settlement. |
| Landfill Gas Recovery   | Landfill gas can be recovered in conj with other site end uses, including recreation, commercial development, e Coordination between activities is im since access to recovery wells and collection header piping must be main   |

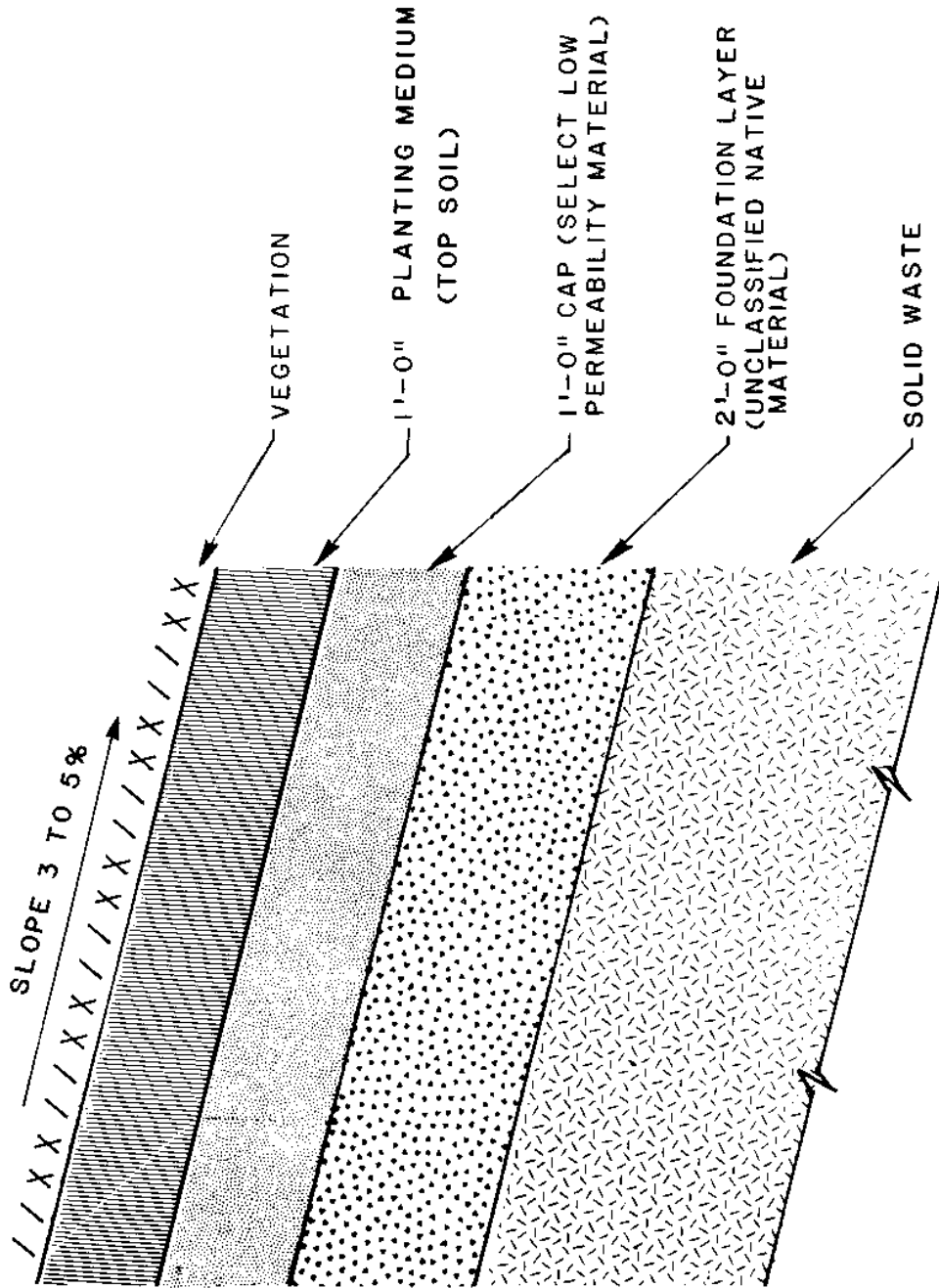

Figure 26  
Final Landfill Surface for Leachate Control

f) Approval of site closure plan report. Many states require that a final site closure plan report be submitted for approval before a landfill site can be officially closed. The closure plan report incorporates the above-mentioned activities. The required components of the closure plan report are given in Table 27.

g) Postclosure monitoring. The monitoring schedule will call for frequent monitoring initially (e.g., once per month) with these frequencies generally reduced after a year or so if there are no problems during that time. Postclosure monitoring elements to be covered include:

- 1) Groundwater quality.
- 2) Leachate volumes generated and effectiveness of leachate control facilities in controlling infiltration into groundwater.
- 3) Surface water quality.
- 4) Effectiveness of landfill gas control facilities in controlling landfill gas migration.
- 5) Settlement and subsequent surface ponding.

h) Postclosure maintenance. Maintenance of mechanical items will generally be per manufacturer's recommendation. Maintenance frequencies other items will be based on need. Typical maintenance items include:

- 1) Clearing drainage and flood control facilities of debris (e.g., mud, leaves, and plant growth if natural channels are employed).
- 2) Filling surface depressions caused by differential settlement.
- 3) Replacement of trees and other vegetation destroyed by landfill gas in the root zone.
- 4) Eroded slopes.
- 5) Ensure that landfill gas control equipment is working and is being utilized.
- 6) Maintain pumps to remove collected leachate.
- 7) Repair damaged road surfaces.

7.7 Personnel. The variety of positions and subsequently, the number of employees required at a landfill depends on the size of the operation. For small sites handling less than 50 to 70 tons (45 to 64 metric tons) per day a single full-time operator may be able to satisfactorily operate equipment, record waste quantities, and perform administrative and maintenance functions. Larger sites will require more positions, including one or more of the following:

- a) Supervisor
- b) Equipment operator.
- c) Check station attendant.
- d) Mechanics.
- e) Laborers.



7.8 Management. The manager of a landfill site has the following responsibilities:

- a) Assure that operations are in conformance with design plans and regulations.
- b) Strive to make daily operations run smoothly.
- c) Maintain site security.
- d) Purchase equipment and assure appropriate maintenance.
- e) Personnel training and safety.
- f) Personnel and user relations.
- g) Record keeping (equipment, personnel, and operations).
- h) Budgets.

7.9 Costs. It is important to keep cost records. Figures 27 through 29 illustrate cost accounting forms for land, equipment, and other facilities. The figures are taken from SCS Engineers, Sanitary Landfill Design and Operations Practices. Some of the columns may therefore not be applicable to the Navy.

Sanitary landfill costs can be categorized into capital costs and operating costs.

7.9.1 Capital Costs. Capital costs are meant to include all initial expenses required prior to the startup of operation. Capital costs generally include:

- a) Land acquisition.
- b) Planning and design.
- c) Site preparation (i.e., clearing and grubbing, road construction, surface water and leachate controls, soil stockpiles, monitoring).
- d) Facilities (i.e., offices, personnel shelters, garages, etc.).
- e) Equipment purchase. The cost of equipment may be the greatest portion of initial expenditures. The landfill equipment market is competitive, but rough approximations of costs can be obtained from a local equipment supplier. As a rule of thumb, a piece of landfill equipment used for excavating, spreading, and compacting has a useful life of 5 years or 10,000 operating hours, whichever comes first. Due to the high cost of equipment, however, it may be prudent to overhaul the machine at the end of 5 years or 10,000 operating hours, and then replace the machine after another 2 to 3 years, or 5,000 to 7,000 hours.

7.9.2 Operating Costs. Operating costs are expenses incurred during the ongoing operation of the landfill.

It is common to compute operating costs as cost per unit of solid waste received. This is usually expressed in dollars per ton, or occasionally dollars per cubic yard. Figure 30 is an example of an accounting form used to record operating costs. Using the depreciation schedule, capital and operating costs are combined and expressed as total costs per unit of solid waste disposed. A more complete discussion of landfill costs is presented in Booz, Allen, and Hamilton, Cost Estimating Handbook for Transfer, Shredding, and Sanitary Landfilling of Solid Waste.



Sites: \_\_\_\_\_

Period of Report: from \_\_\_\_\_ to \_\_\_\_\_

|                     | Data                                | Actual<br>this period | \$ var.<br>from<br>budget | \$ var.<br>from last<br>period | \$ var.<br>this period<br>last year |
|---------------------|-------------------------------------|-----------------------|---------------------------|--------------------------------|-------------------------------------|
| Totals              | Total tons received                 |                       |                           |                                |                                     |
|                     | Total operating cost                |                       |                           |                                |                                     |
|                     | Total operating cost/ton            |                       |                           |                                |                                     |
| Unit costs*         | Labor/ton                           |                       |                           |                                |                                     |
|                     | Cover material/ton                  |                       |                           |                                |                                     |
|                     | Equipment operation/ton             |                       |                           |                                |                                     |
|                     | Overhead/ton                        |                       |                           |                                |                                     |
| Efficiency factors* | Cover material utilized             |                       |                           |                                |                                     |
|                     | Overtime hours/total<br>labor hours |                       |                           |                                |                                     |
|                     | Labor efficiency                    |                       |                           |                                |                                     |
|                     | Equipment % downtime                |                       |                           |                                |                                     |
|                     | Equipment utilization               |                       |                           |                                |                                     |
|                     | Equipment efficiency                |                       |                           |                                |                                     |

\* Calculations: Unit cost = aggregate cost ÷ tons solid waste received. Note that cover material unit cost is cover material cost ÷ tons of solid waste received.

Cover material utilization = cover material used ÷ tons of solid waste received.

Labor efficiency = tons received ÷ labor hours.

Equipment utilization = tons received ÷ equipment hours.

Equipment efficiency = equipment cost ÷ equipment hours.

Equipment % downtime = total hours ÷ total equipment hours.

Figure 28  
Landfill Cost Data Sheet

Site: \_\_\_\_\_

Date: \_\_\_\_\_

| Item or Category      | Description | Date put in use | New cost | Estimated total life | Other comments | Annual depreciation | Monthly depreciation |
|-----------------------|-------------|-----------------|----------|----------------------|----------------|---------------------|----------------------|
| Land                  |             |                 |          |                      |                |                     |                      |
| Roads                 |             |                 |          |                      |                |                     |                      |
| Lights                |             |                 |          |                      |                |                     |                      |
| Fences                |             |                 |          |                      |                |                     |                      |
| Surveys               |             |                 |          |                      |                |                     |                      |
| Stormwater            |             |                 |          |                      |                |                     |                      |
| Management facilities |             |                 |          |                      |                |                     |                      |
| Monitoring wells      |             |                 |          |                      |                |                     |                      |
| Scales                |             |                 |          |                      |                |                     |                      |
| Garages               |             |                 |          |                      |                |                     |                      |
| Buildings             |             |                 |          |                      |                |                     |                      |
| Other                 |             |                 |          |                      |                |                     |                      |
| Totals                |             |                 |          |                      |                |                     |                      |

Instructions: To be completed by supervisor or accounting department, if they have data available. "Estimated total life" should be based on remaining life as estimated by the supervisor. Land purchased subsequent to the original land purchase should be included. Depreciation may be either straight-line or on an accelerated basis.

Figure 29  
Operating Costs

LANDFILL TOTAL COST REPORT

Site: \_\_\_\_\_ Period of Report: from \_\_\_\_\_ to \_\_\_\_\_

| Data                         | For this period | Budget-this period | Year to date | Budget-year to date |
|------------------------------|-----------------|--------------------|--------------|---------------------|
| Tons of solid waste received |                 |                    |              |                     |
| Total operating cost         |                 |                    |              |                     |
| Total depreciation cost      |                 |                    |              |                     |
| Total cost                   |                 |                    |              |                     |
| Operating cost per ton       |                 |                    |              |                     |
| Depreciation cost per ton    |                 |                    |              |                     |
| Total cost per ton           |                 |                    |              |                     |

Instructions: To be completed by the accounting department, when requested or periodically, from data available in operating cost report or capital cost reports. Copies sent to the city manager (or his equivalent).

Figure 30  
Total Cost Per Unit of Solid Waste

Typical costs are difficult to assess since local conditions vary considerably. A hauling operation that has good roads, light traffic, and moderate weather conditions would have a lower cost than the average. Operating costs generally include:

- a) Equipment fuel.
- b) Equipment maintenance and parts. Equipment maintenance and repair costs (both parts and labor) vary widely; but assuming a useful life of 10,000 hours, maintenance costs can be expected to total approximately one-half of the initial cost of the machine. To make these costs more predictable, most equipment dealers offer lease agreements and maintenance contracts. Long downtimes usually associated with major repairs can be reduced by taking advantage of programs offered by equipment dealers.
- c) Office trailer rental.
- d) Supplies and materials.
- e) Utilities (i.e., electricity, heating oil, water, sewer, gas telephone, etc.).
- f) Laboratory analyses.
- g) Personnel.
- h) Ongoing inspection and engineering.

## REFERENCES

Atomic Energy Act of 1954, as amended, 68 Stat. 923, available from the Superintendent of Documents, U.S. Government Printing Office, Washington DC 20402.

Cost Estimating Handbook for Transfer, Shredding, And Sanitary Landfill in of Solid Waste; Booz, Allen, and Hamilton; New York, NY, August 1976.

Department of Defense Manuals; government activities may obtain from Nava Publications and Forms Center, 5801 Tabor Avenue, Philadelphia, PA 19120; private organizations may purchase from the Superintendent of Documents, U.S. Government Printing Office, Washington, DC 20402.

DOD 4165.60                      Solid Waste Management - Collection, Disposal, Resource Recovery and Recycling Programs "A and L", October 1976.

DOD 4270.1-M                    Construction Criteria Manual, June 1978.

Environmental and Natural Resources Manual, OPNAVINST 5090.1, available from Naval Publications and Forms Center, 5801 Tabor Avenue, Philadelphia PA 19120, May 1983.

Environmental Protection Agency (EPA) guidelines, available from the Superintendent of Documents, U.S. Government Printing Office, Washington, DC 20402.

40 CFR 240                      Guidelines for the Thermal Processing of Solid Wastes

40 CFR 241                      Guidelines for the Land Disposal of Solid Wastes

40 CFR 243                      Guidelines for the Storage and Collection of Residential, Commercial, and Institutional Solid Waste

40 CFR 245                      Promulgation Resources Recovery Facilities Guidelines

40 CFR 246                      Sources Separation for Materials Recovery

40 CFR 247                      Guidelines for Procurement of Products that Contained Recycled Material

40 CFR 255                      Identification of Regions and Agencies for Solid Waste Management

40 CFR 256                      Guidelines for Development and Implementation of State Solid Waste Management Plans

40 CFR 257                      Criteria for classification of Solid Waste Disposal Facilities and Practices

Moisture-Density Relations of Soils and Soil-Aggregate Mixture, D-698, American Society for Testing and Materials, 1916 Race Street, Philadelphia PA 19103.

National Water Data Exchange, U.S. Geological Survey, Reston, VA, Phone (703) 648-6818 or 648-5000. Note that reports or regional office location can be obtained from USGS by telephone.

Naval Facilities Engineering Command (NAVFAC) Design Manuals (DM), Maintenance Operation Manuals (MO), and Military Handbooks (MIL-HDBK) available from Naval Publications and Forms Center, 5801 Tabor Avenue, Philadelphia, PA 19120.

|                 |   |
|-----------------|---|
| DM-5.01         | Surveying   |
| DM-5.02         | Hydrology   |
| DM-5.03         | Drainage Systems  |
| DM-5.04         | Pavements   |
| DM-5.05         | General Provisions and Geometric Design for Roads, Streets, Walks, and Open Storage Areas |
| DM-5.08         | Domestic Wastewater Control.  |
| DM-5.09         | Industrial and Oily Wastewater Control.   |
| DM-5.12         | Fencing, Gates, and Guard Towers  |
| DM-5.13         | Hazardous Waste Storage and Transfer Facilities   |
| DM-5.14         | Groundwater Pollution Control   |
| MO-213          | Solid Waste Management  |
| MIL-HDBK-1003/2 | Incinerators  |

Occupational Noise Exposure, 29 CFR 1910.95, Occupational Safety and Health Act (OSHA) Standard, available from superintendent of Documents, U.S. Government Printing Office, Washington, DC 20402.

Phase II of the Waste Assessment for Navy Shore Activities: Proposed Survey Method, Naval Civil Engineering Laboratory Technical Notes TN-1712, available from Naval Civil Engineering Laboratory, Port Hueneme, CA 93043 October 1984.

Recommended Design of 50 TDP Facility, Naval Civil Engineering Laboratory 84.014, available from Naval Civil Engineering Laboratory, Port Hueneme, CA 93043.

Resources Conservation and Recovery Act of 1976, Subtitle C of Public Law 94-580, available from Superintendent of Documents, U.S. Government Printing Office, Washington, DC 20402.

Stearns, Conrad, and Schmidt Engineers, 4014 Long Beach Boulevard, Long Beach, CA 90807

Analysis of Responses to Questionnaires for Naval Shore Facilities, So Waste Management Practices and Procedures, CR 73.012

Sanitary Landfill Design and Operation Procedures, EPA Contract No. 68-01-3915

Solid Waste Composition and Emission Factors for Selected Naval Activities, CR 73.011

Waste Disposal to Land, Subchapter 15, California Water Regulations, California State Resources Central Board, Division of Water Quality, P.O. Box 100, Sacramento, CA 95801



# INDEX

|                                       | Page   |
|---------------------------------------|--------|
| A                                     |        |
| Access roads                          | 5. 10- |
| Aesthetics                            | 5. 10- |
| Air classification                    | 5. 10- |
| Air quality                           |        |
| Landfill site                         | 5. 10- |
| Transfer stations                     | 5. 10- |
| Archaeological significance           | 5. 10- |
| Attractive nuisance                   | 5. 10- |
| B                                     |        |
| Baling                                | 5. 10- |
| Bird hazards                          | 5. 10- |
| C                                     |        |
| Closure and postclosure,<br>Landfills | 5. 10- |
| Collection and hauling<br>options     | 5. 10- |
| Collection vehicles                   | 5. 10- |
| Compaction systems                    | 5. 10- |
| Composting                            | 5-10-  |
| D                                     |        |
| Densification                         | 5-10-  |
| E                                     |        |
| Environmental impacts                 | 5. 10- |
| Environmental safeguards              | 5. 10- |
| F                                     |        |
| Fencing                               | 5. 10- |
| Fires                                 | 5. 10- |
| G                                     |        |
| Gasification                          | 5. 10- |
| Geology                               | 5. 10- |
| Groundwater                           | 5. 10- |
| H                                     |        |
| Hauling, waste                        | 5. 10- |
| I                                     |        |
| Incineration                          | 5. 10- |
| L                                     |        |

|              |       |
|--------------|-------|
| Landfill     |       |
| Equipment    | 5.10- |
| Location     | 5.10- |
| Methods      | 5.10- |
| Landfill gas | 5.10- |
| Leachate     | 5.10- |
| Lighting     | 5.10- |
| Litter       | 5.10- |

M

|                      |       |
|----------------------|-------|
| Magnetic separation  | 5.10- |
| Management, landfill | 5.10- |

N

|       |       |
|-------|-------|
| Noise | 5.10- |
|-------|-------|

O

|       |       |
|-------|-------|
| Odors | 5.10- |
|-------|-------|

P

|                          |       |
|--------------------------|-------|
| Personnel                | 5.10- |
| Policies                 | 5.10- |
| Public health and safety | 5.10- |

R

|                   |       |
|-------------------|-------|
| Regulations       | 5.10- |
| Resource recovery | 5.10- |

S

|        |       |
|--------|-------|
| Scales | 5-10- |
|--------|-------|

# INDEX

|                                     | Page   |
|-------------------------------------|--------|
| Screening                           | 5. 10- |
| Site life, landfill                 | 5. 10- |
| Site proximity                      | 5. 10- |
| Site selection, landfill            | 5. 10- |
| Size reduction                      | 5. 10- |
| Soils                               |        |
| Cover                               | 5. 10- |
| Attenuate potential<br>contaminants | 5. 10- |
| Solid waste                         |        |
| From foreign sources                | 5. 10- |
| Quantities                          | 5. 10- |
| Onsite                              | 5. 10- |
| Storage                             | 5. 10- |
| Types                               | 5. 10- |
| Source separation                   | 5. 10- |
| Special working areas               | 5. 10- |
| Storm water management              | 5. 10- |
| Surface water                       | 5. 10- |
| T                                   |        |
| Topography                          | 5. 10- |
| Traffic congestion                  | 5. 10- |
| Transfer stations                   |        |
| Siting                              | 5. 10- |
| Types                               | 5. 10- |
| U                                   |        |
| Utilities                           | 5. 10- |
| V                                   |        |
| Vegetation                          | 5. 10- |
| Vectors                             | 5. 10- |
| W                                   |        |
| Wash rack                           | 5. 10- |
| Water contamination                 | 5. 10- |

5. 10-120

\*U. S. GOVERNMENT PRINTING OFFICE : 1987 0 - 175-980