

# CIVE1400: An Introduction to Fluid Mechanics

**Dr P A Sleigh**

P.A.Sleigh@leeds.ac.uk

**Dr CJ Noakes**

C.J.Noakes@leeds.ac.uk

January 2008

Module web site:

[www.efm.leeds.ac.uk/CIVE/FluidsLevel1](http://www.efm.leeds.ac.uk/CIVE/FluidsLevel1)

Unit 1: Fluid Mechanics Basics	3 lectures
Flow	
Pressure	
Properties of Fluids	
Fluids vs. Solids	
Viscosity	
Unit 2: Statics	3 lectures
Hydrostatic pressure	
Manometry/Pressure measurement	
Hydrostatic forces on submerged surfaces	
Unit 3: Dynamics	7 lectures
The continuity equation.	
The Bernoulli Equation.	
Application of Bernoulli equation.	
The momentum equation.	
Application of momentum equation.	
Unit 4: Effect of the boundary on flow	4 lectures
Laminar and turbulent flow	
Boundary layer theory	
An Intro to Dimensional analysis	
Similarity	

# Notes For the First Year Lecture Course: An Introduction to Fluid Mechanics

School of Civil Engineering, University of Leeds.

**CIVE1400 FLUID MECHANICS**

**Dr Andrew Sleigh**

January 2008

## Contents of the Course

### **Objectives:**

The course will introduce fluid mechanics and establish its relevance in civil engineering.

Develop the fundamental principles underlying the subject.

Demonstrate how these are used for the design of simple hydraulic components.

### **Civil Engineering Fluid Mechanics**

Why are we studying fluid mechanics on a Civil Engineering course? The provision of adequate water services such as the supply of potable water, drainage, sewerage is essential for the development of industrial society. It is these services which civil engineers provide.

Fluid mechanics is involved in nearly all areas of Civil Engineering either directly or indirectly. Some examples of direct involvement are those where we are concerned with manipulating the fluid:

Sea and river (flood) defences;

Water distribution / sewerage (sanitation) networks;

Hydraulic design of water/sewage treatment works;

Dams;

Irrigation;

Pumps and Turbines;

Water retaining structures.

And some examples where the primary object is construction - yet analysis of the fluid mechanics is essential:

Flow of air in buildings;

Flow of air around buildings;

Bridge piers in rivers;

Ground-water flow – much larger scale in time and space.

Notice how nearly all of these involve water. The following course, although introducing general fluid flow ideas and principles, the course will demonstrate many of these principles through examples where the fluid is water.

**Module Consists of:**Lectures:

20 Classes presenting the concepts, theory and application.

Worked examples will also be given to demonstrate how the theory is applied. You will be asked to do some calculations - so **bring a calculator**.

Assessment:

**1 Exam of 2 hours**, worth 80% of the module credits.

This consists of 6 questions of which you choose 4.

**2 Multiple choice question (MCQ) papers**, worth 10% of the module credits (5% each).

These will be for 30mins and set after the lectures. The timetable for these MCQs and lectures is shown in the table at the end of this section.

**1 Marked problem sheet**, worth 10% of the module credits.

Laboratories: 2 x 3 hours

These two laboratory sessions examine how well the theoretical analysis of fluid dynamics describes what we observe in practice.

During the laboratory you will take measurements and draw various graphs according to the details on the laboratory sheets. These graphs can be compared with those obtained from theoretical analysis.

You will be expected to draw conclusions as to the validity of the theory based on the results you have obtained and the experimental procedure.

After you have completed the two laboratories you should have obtained a greater understanding as to how the theory relates to practice, what parameters are important in analysis of fluid and where theoretical predictions and experimental measurements may differ.

The two laboratories sessions are:

1. Impact of jets on various shaped surfaces - a jet of water is fired at a target and is deflected in various directions. This is an example of the application of the momentum equation.
2. The rectangular weir - the weir is used as a flow measuring device. Its accuracy is investigated. This is an example of how the Bernoulli (energy) equation is applied to analyses fluid flow.

[As you know, these laboratory sessions are **compulsory** course-work. You must attend them. Should you fail to attend either one you will be asked to complete some extra work. This will involve a detailed report and further questions. The simplest strategy is to do the lab.]

Homework:

*Example sheets:* These will be given for each section of the course. Doing these will **greatly** improve your exam mark. They are course work but do not have credits toward the module.

*Lecture notes:* Theses should be studied but explain only the basic outline of the necessary concepts and ideas.

*Books:* It is very important do some extra reading in this subject. To do the examples you will definitely need a textbook. Any one of those identified below is adequate and will also be useful for the fluids (and other) modules in higher years - and in work.

Example classes:

There will be example classes each week. You may bring any problems/questions you have about the course and example sheets to these classes.

## Schedule:

Lecture	Month	Date	Week	Day	Time	Unit	
1	January	15	0	Tue s	3.00 pm	<b>Unit 1: Fluid Mechanic Basics</b>	Pressure, density
2		16	0	Wed	9.00 am		Viscosity, Flow
Extra		22	1	Tue s	3.00 pm	Presentation of Case Studies	double lecture
3		23	1	Wed	9.00 am		Flow calculations
4		29	2	Tue s	3.00 pm	<b>Unit 2: Fluid Statics</b>	Pressure
5		30	2	Wed	9.00 am		Plane surfaces
6	February	5	3	Tue s	3.00 pm		Curved surfaces
7		6	3	Wed	9.00 am	Design study 01 - Centre vale park	
8		12	4	Tue s	3.00 pm	<b>Unit 3: Fluid Dynamics</b>	General
9		13	4	Wed	9.00 am		Bernoulli
10		19	5	Tue s	3.00 pm		Flow measurement
MCQ					4.00 pm	<b>MCQ</b>	
11		20	5	Wed	9.00 am		Weir
12	surveyin g	26	6	Tue s	3.00 pm		Momentum
13		27	6	Wed	9.00 am	Design study 02 - Gaunless + Millwood	
12	March	4	7	Tue s	3.00 pm		Applications
13		5	7	Wed	9.00 am	Design study 02 - Gaunless + Millwood	
14		11	8	Tue s	3.00 pm		Applications
15		12	8	Wed	9.00 am	problem sheet given out	Calculation
			Vacatio n				
16	April	15	9	Tue s	3.00 pm	<b>Unit 4: Effects of the Boundary on Flow</b>	Boundary Layer
17		16	9	Wed	9.00 am		Friction
18		22	10	Tue s	3.00 pm		Dim. Analysis
19		23	10	Wed	9.00 am	problem sheet handed in	Dim. Analysis
20		29	11	Tue s	3.00 pm	<b>Revision</b>	
MCQ					4.00 pm	<b>MCQ</b>	
21		30	11	Wed	9.00 am		

**Books:**

Any of the books listed below are more than adequate for this module. (You will probably not need any more fluid mechanics books on the rest of the Civil Engineering course)

Mechanics of Fluids, Massey B S., Van Nostrand Reinhold.

Fluid Mechanics, Douglas J F, Gasiorek J M, and Swaffield J A, Longman.

Civil Engineering Hydraulics, Featherstone R E and Nalluri C, Blackwell Science.

Hydraulics in Civil and Environmental Engineering, Chadwick A, and Morfett J., E & FN Spon - Chapman & Hall.

**Online Lecture Notes:**

**<http://www.efm.leeds.ac.uk/cive/FluidsLevel1>**

There is a **lot** of extra teaching material on this site: Example sheets, Solutions, Exams, Detailed lecture notes, Online video lectures, MCQ tests, Images etc. This site DOES NOT REPLACE LECTURES or BOOKS.

### ***Take care with the System of Units***

As any quantity can be expressed in whatever way you like it is sometimes easy to become confused as to what exactly or how much is being referred to. This is particularly true in the field of fluid mechanics. Over the years many different ways have been used to express the various quantities involved. Even today different countries use different terminology as well as different units for the same thing - they even use the same name for different things e.g. an American pint is 4/5 of a British pint!

To avoid any confusion on this course we will always use the SI (metric) system - which you will already be familiar with. It is essential that all quantities are expressed in the same system or the wrong solutions will result.

Despite this warning you will still find that this is the most common mistake when you attempt example questions.

### ***The SI System of units***

The SI system consists of six **primary** units, from which all quantities may be described. For convenience **secondary** units are used in general practice which are made from combinations of these primary units.

### **Primary Units**

The six **primary** units of the SI system are shown in the table below:

<b>Quantity</b>	<b>SI Unit</b>	<b>Dimension</b>
Length	metre, m	L
Mass	kilogram, kg	M
Time	second, s	T
Temperature	Kelvin, K	$\theta$
Current	ampere, A	I
Luminosity	candela	Cd

In fluid mechanics we are generally only interested in the top four units from this table.

Notice how the term 'Dimension' of a unit has been introduced in this table. This is not a property of the individual units, rather it tells what the unit represents. For example a metre is a length which has a dimension L but also, an inch, a mile or a kilometre are all lengths so have dimension of L.

(The above notation uses the MLT system of dimensions, there are other ways of writing dimensions - we will see more about this in the section of the course on dimensional analysis.)

**Derived Units**

There are many **derived** units all obtained from combination of the above **primary** units. Those most used are shown in the table below:

Quantity	SI Unit		Dimension
Velocity	m/s	ms <sup>-1</sup>	LT <sup>-1</sup>
acceleration	m/s <sup>2</sup>	ms <sup>-2</sup>	LT <sup>-2</sup>
force	N kg m/s <sup>2</sup>	kg ms <sup>-2</sup>	M LT <sup>-2</sup>
energy (or work)	Joule J N m, kg m <sup>2</sup> /s <sup>2</sup>	kg m <sup>2</sup> s <sup>-2</sup>	ML <sup>2</sup> T <sup>-2</sup>
power	Watt W N m/s kg m <sup>2</sup> /s <sup>3</sup>	Nms <sup>-1</sup> kg m <sup>2</sup> s <sup>-3</sup>	ML <sup>2</sup> T <sup>-3</sup>
pressure ( or stress)	Pascal P, N/m <sup>2</sup> , kg/m/s <sup>2</sup>	Nm <sup>-2</sup> kg m <sup>-1</sup> s <sup>-2</sup>	ML <sup>-1</sup> T <sup>-2</sup>
density	kg/m <sup>3</sup>	kg m <sup>-3</sup>	ML <sup>-3</sup>
specific weight	N/m <sup>3</sup> kg/m <sup>2</sup> /s <sup>2</sup>	kg m <sup>-2</sup> s <sup>-2</sup>	ML <sup>-2</sup> T <sup>-2</sup>
relative density	a ratio no units		1 no dimension
viscosity	N s/m <sup>2</sup> kg/m s	N sm <sup>-2</sup> kg m <sup>-1</sup> s <sup>-1</sup>	M L <sup>-1</sup> T <sup>-1</sup>
surface tension	N/m kg /s <sup>2</sup>	Nm <sup>-1</sup> kg s <sup>-2</sup>	MT <sup>-2</sup>

The above units should be used at all times. Values in other units should NOT be used without first converting them into the appropriate SI unit. If you do not know what a particular unit means - **find out**, else your guess will probably be wrong.

More on this subject will be seen later in the section on dimensional analysis and similarity.

## Properties of Fluids: Density

There are three ways of expressing density:

### 1. Mass density:

$\rho =$  mass per unit volume

$$\rho = \frac{\text{mass of fluid}}{\text{volume of fluid}}$$

**(units: kg/m<sup>3</sup>)**

### 2. Specific Weight:

**(also known as specific gravity)**

$\omega =$  weight per unit volume

$$\omega = \rho g$$

**(units: N/m<sup>3</sup> or kg/m<sup>2</sup>/s<sup>2</sup>)**

### 3. Relative Density:

$\sigma =$  ratio of mass density to  
a standard mass density

$$\sigma = \frac{\rho_{\text{substance}}}{\rho_{H_2O(\text{at } 4^\circ \text{C})}}$$

**For solids and liquids this standard mass density is the maximum mass density for water (which occurs at 4° c) at atmospheric pressure.**

**(units: none, as it is a ratio)**

## Pressure

**Convenient to work in terms of pressure,  $p$ ,  
which is the force per unit area.**

$$\text{pressure} = \frac{\text{Force}}{\text{Area over which the force is applied}}$$

$$p = \frac{F}{A}$$

**Units: Newtons per square metre,  
 $N/m^2$ ,  $kg/m\ s^2$  ( $kg\ m^{-1}\ s^{-2}$ ).**

**Also known as a Pascal,  $Pa$ , i.e.  $1\ Pa = 1\ N/m^2$**

**Also frequently used is the alternative SI unit the *bar*,  
where  $1\ bar = 10^5\ N/m^2$**

**Standard atmosphere =  $101325\ Pa = 101.325\ kPa$**

**$1\ bar = 100\ kPa$  (kilopascals)**

**$1\ mbar = 0.001\ bar = 0.1\ kPa = 100\ Pa$**

### **Uniform Pressure:**

**If the pressure is the same at all points on a surface  
*uniform* pressure**

## Pascal's Law: pressure acts equally in all directions.

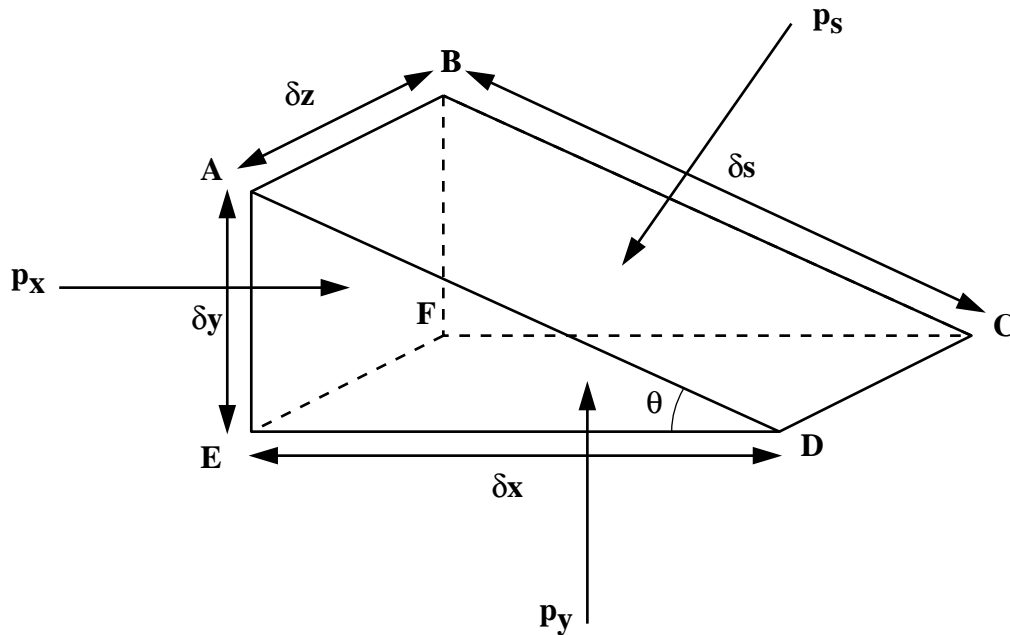

**No shearing forces :**

**All forces at right angles to the surfaces**

**Summing forces in the x-direction:**

**Force in the x-direction due to  $p_x$ ,**

$$F_{x_x} = p_x \times \text{Area}_{ABFE} = p_x \delta x \delta y$$

**Force in the x-direction due to  $p_s$ ,**

$$F_{x_s} = -p_s \times \text{Area}_{ABCD} \times \sin \theta$$

$$= -p_s \delta s \delta z \frac{\delta y}{\delta s}$$

$$= -p_s \delta y \delta z$$

$$(\sin \theta = \frac{\delta y}{\delta s})$$

**Force in x-direction due to  $p_y$ ,**

$$F_{x_y} = 0$$

**To be at rest (in equilibrium) sum of forces is zero**

$$F_{x_x} + F_{x_s} + F_{x_y} = 0$$

$$p_x \delta x \delta y + (-p_s \delta y \delta z) = 0$$

$$p_x = p_s$$

**Summing forces in the y-direction.**

**Force due to  $p_y$ ,**

$$F_{y_y} = p_y \times \text{Area}_{EFCD} = p_y \delta x \delta z$$

**Component of force due to  $p_s$ ,**

$$F_{y_s} = -p_s \times \text{Area}_{ABCD} \times \cos \theta$$

$$= -p_s \delta s \delta z \frac{\delta x}{\delta s}$$

$$= -p_s \delta x \delta z$$

$$(\cos \theta = \frac{\delta x}{\delta s})$$

**Component of force due to  $p_x$ ,**

$$F_{y_x} = 0$$

**Force due to gravity,**

$$\begin{aligned} \text{weight} &= -\text{specific weight} \times \text{volume of element} \\ &= -\rho g \times \frac{1}{2} \delta x \delta y \delta z \end{aligned}$$

**To be at rest (in equilibrium)**

$$F_{y_y} + F_{y_s} + F_{y_x} + \text{weight} = 0$$

$$p_y \delta x \delta y + (-p_s \delta x \delta z) + \left( -\rho g \frac{1}{2} \delta x \delta y \delta z \right) = 0$$

**The element is small i.e.  $\delta x$ ,  $\delta y$ , and  $\delta z$ , are small,  
so  $\delta x \times \delta y \times \delta z$ , is very small  
and considered negligible, hence**

$$p_y = p_s$$

**We showed above**

$$p_x = p_s$$

**thus**

$$p_x = p_y = p_s$$

**Pressure at any point is the same in all directions.**

**This is Pascal's Law and applies to fluids at rest.**

## **Change of Pressure in the Vertical Direction**

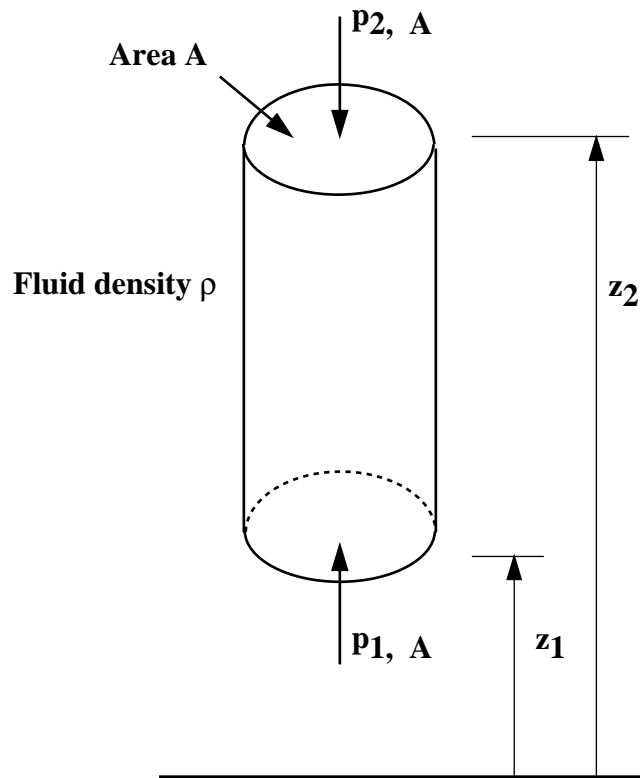

**Cylindrical element of fluid, area =  $A$ , density =  $\rho$**

**The forces involved are:**

**Force due to  $p_1$  on  $A$  (upward) =  $p_1 A$**

**Force due to  $p_2$  on  $A$  (downward) =  $p_2 A$**

**Force due to weight of element (downward)**

**=  $mg = \text{density} \times \text{volume} \times g$**

**=  $\rho g A(z_2 - z_1)$**

**Taking upward as positive, we have**

$$p_1 A - p_2 A - \rho g A(z_2 - z_1) = 0$$

$$p_2 - p_1 = -\rho g(z_2 - z_1)$$

**In a fluid pressure decreases linearly with increase in height**

$$p_2 - p_1 = -\rho g(z_2 - z_1)$$

**This is the hydrostatic pressure change.**

**With liquids we normally measure *from the surface*.**

**Measuring *h down* from the free surface so that  $h = -z$**

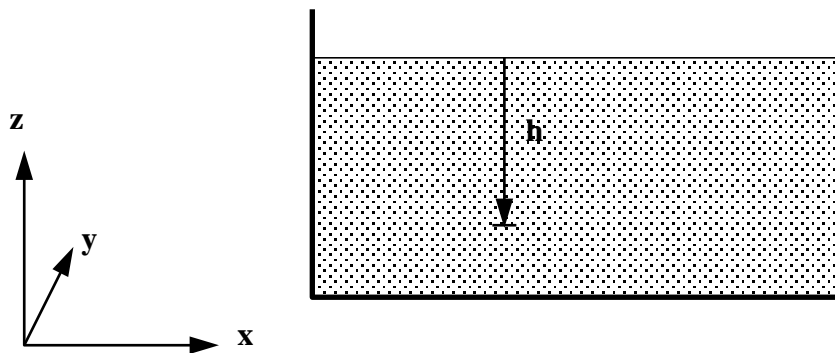

**giving**  $p_2 - p_1 = \rho g h$

**Surface pressure is atmospheric,  $p_{\text{atmospheric}}$**

$$p = \rho g h + p_{\text{atmospheric}}$$

**It is convenient to take atmospheric pressure as the datum**

**Pressure quoted in this way is known as gauge pressure i.e.**

**Gauge pressure is**

$$p_{gauge} = \rho g h$$

**The lower limit of any pressure is the pressure in a perfect vacuum.**

**Pressure measured above a perfect vacuum (zero) is known as absolute pressure**

**Absolute pressure is**

$$p_{absolute} = \rho g h + p_{atmospheric}$$

***Absolute pressure = Gauge pressure + Atmospheric***

## Pressure density relationship

### Boyle's Law

$$pV = \text{constant}$$

### Ideal gas law

$$pV = nRT$$

where

$p$  is the absolute pressure,  $\text{N/m}^2$ , Pa

$V$  is the volume of the vessel,  $\text{m}^3$

$n$  is the amount of substance of gas, moles

$R$  is the ideal gas constant,

$T$  is the absolute temperature. K

In SI units,  $R = 8.314472 \text{ J mol}^{-1} \text{ K}^{-1}$   
(or equivalently  $\text{m}^3 \text{ Pa K}^{-1} \text{ mol}^{-1}$ ).

## Lecture 2: Fluids vs Solids, Flow

### What makes fluid mechanics different to solid mechanics?

**Fluids are clearly different to solids.  
But we must be specific.**

**Need definable basic physical  
difference.**

**Fluids *flow* under the action of a force,  
and the solids don't - but solids do  
deform.**

- fluids lack the ability of solids to resist deformation.**
- fluids change shape as long as a force acts.**

**Take a rectangular element**

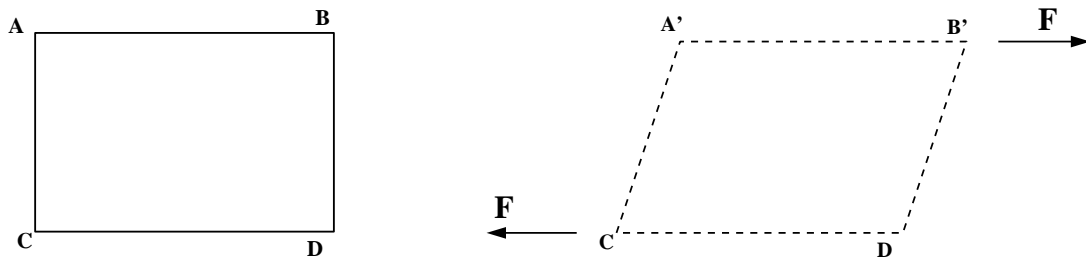

**Forces acting along edges (faces), such as  $F$ , are known as *shearing forces*.**

**A Fluid is a substance which deforms continuously, or flows, when subjected to *shearing forces*.**

**This has the following implications for fluids at rest:**

**If a fluid is at rest there are NO shearing forces acting on it, and any force must be acting perpendicular to the fluid**

## Fluids in motion

Consider a fluid flowing near a wall.  
- in a pipe for example -

Fluid next to the wall will have zero velocity.

The fluid “sticks” to the wall.

Moving away from the wall velocity increases  
to a maximum.

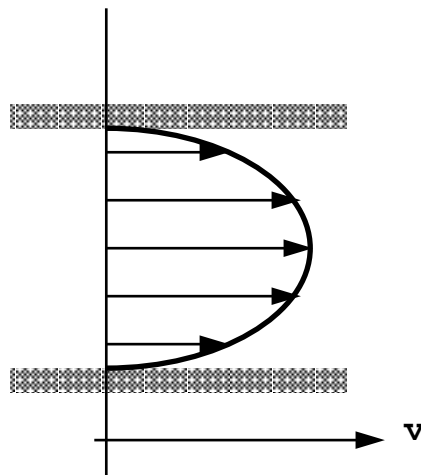

Plotting the velocity across the section gives  
“velocity profile”

Change in velocity with distance is

$$\text{“velocity gradient”} = \frac{du}{dy}$$

**As fluids are usually near surfaces there is usually a velocity gradient.**

**Under normal conditions one fluid particle has a velocity different to its neighbour.**

**Particles next to each other with different velocities exert forces on each other (due to intermolecular action) .....**

**i.e. shear forces exist in a fluid moving close to a wall.**

**What if not near a wall?**

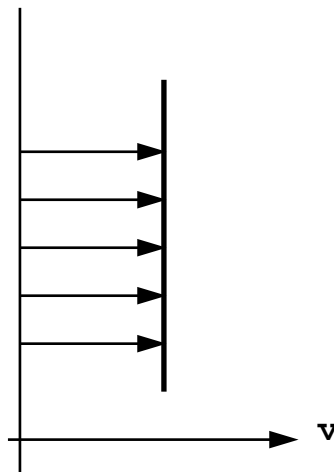

**No velocity gradient, no shear forces.**

## **What use is this observation?**

**It would be useful if we could quantify this shearing force.**

**This may give us an understanding of what parameters govern the forces different fluid exert on flow.**

**We will examine the force required to deform an element.**

**Consider this 3-d rectangular element, under the action of the force  $F$ .**

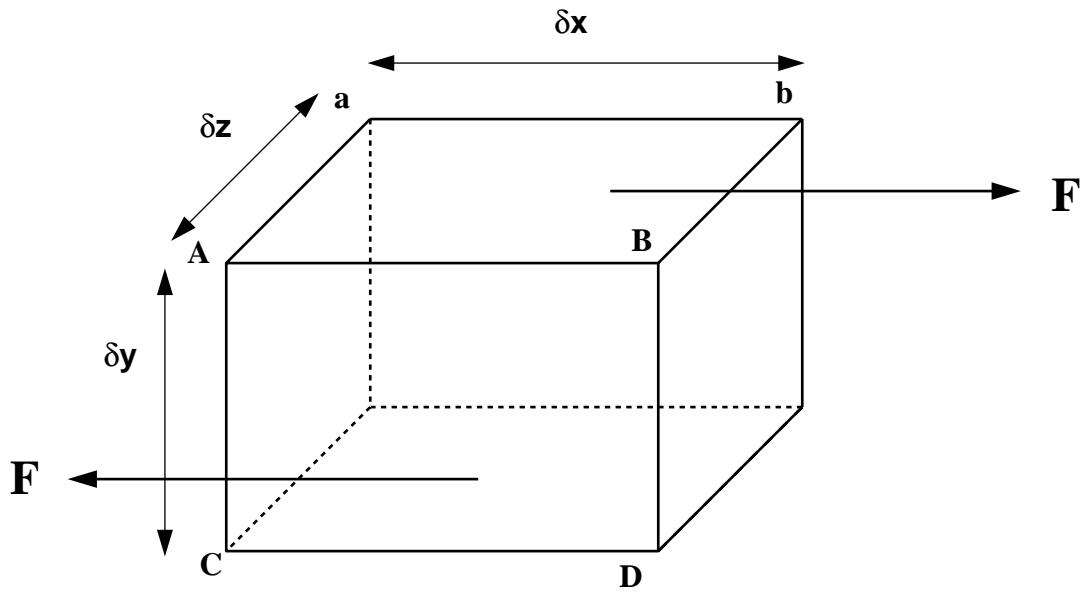

**under the action of the force F**

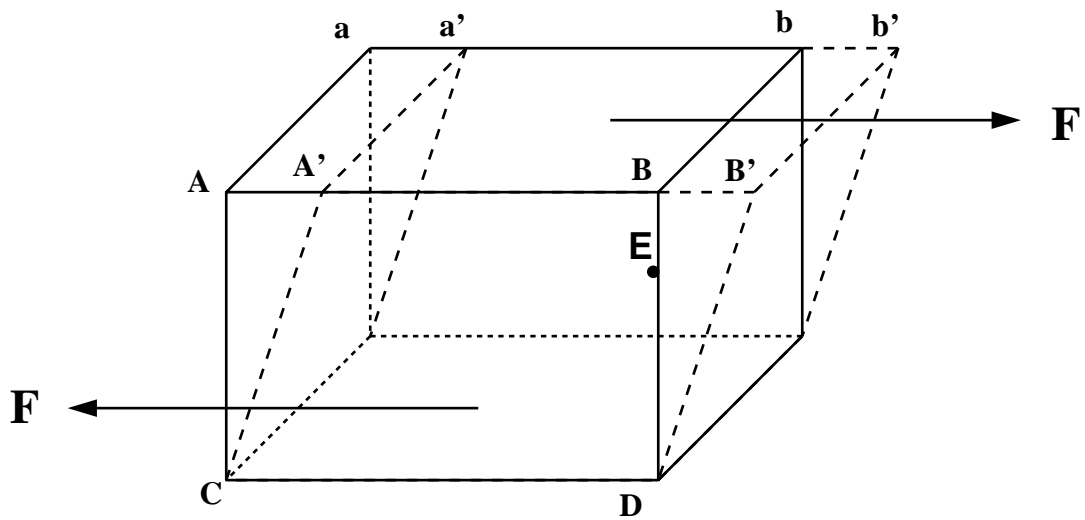

A 2-d view may be clearer...

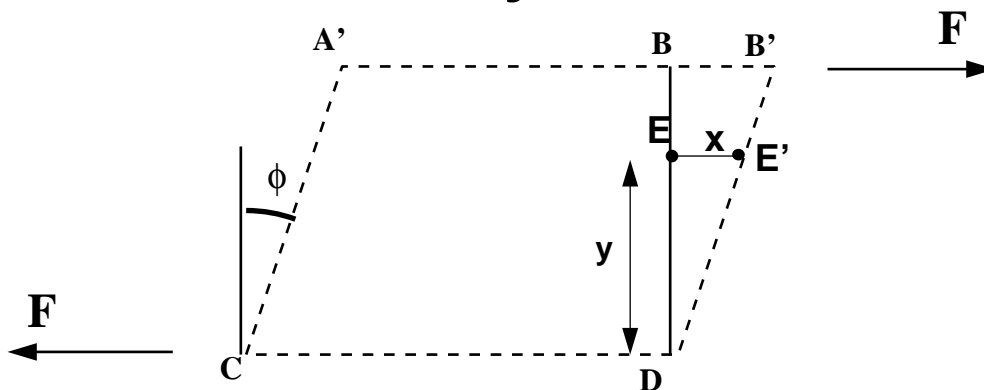

The shearing force acts on the area

$$A = \delta z \times \delta x$$

**Shear stress,  $\tau$ , is the force per unit area:**

$$\tau = \frac{F}{A}$$

The deformation which shear stress causes is measured by the angle  $\phi$ , and is known as shear strain.

Using these definitions we can amend our definition of a fluid:

In a fluid  $\phi$  increases for as long as  $\tau$  is applied - the fluid flows

In a solid shear strain,  $\phi$ , is constant for a fixed shear stress  $\tau$ .

It has been shown experimentally that the *rate of shear strain* is directly proportional to *shear stress*

$$\tau \propto \frac{\phi}{\text{time}}$$

$$\tau = \text{Constant} \times \frac{\phi}{t}$$

We can express this in terms of the cuboid.

If a particle at point E moves to point E' in time t then:

for small deformations

$$\text{shear strain } \phi = \frac{x}{y}$$

$$\text{rate of shear strain} = -$$

$$= \text{---} = \text{---}$$

$$= -$$

(note that  $\frac{x}{t} = u$  is the velocity of the particle at E)

So

$$\tau = \text{Constant} \times \frac{u}{y}$$

$u/y$  is the rate of change of velocity with distance,  
in differential form this is  $\frac{du}{dy}$  = velocity gradient.

The constant of proportionality is known as  
the *dynamic viscosity*,  $\mu$ .

giving

$$\tau = \mu \frac{du}{dy}$$

which is known as *Newton's law of viscosity*

A fluid which obeys this rule is known as a  
*Newtonian Fluid*

(sometimes also called *real fluids*)

Newtonian fluids have constant values of  $\mu$

## Non-Newtonian Fluids

**Some fluids do not have constant  $\mu$ .  
They do not obey Newton's Law of viscosity.**

**They do obey a similar relationship and can  
be placed into several clear categories**

**The general relationship is:**

$$\tau = A + B \left( \frac{\delta u}{\delta y} \right)^n$$

**where A, B and n are constants.**

**For Newtonian fluids  $A = 0$ ,  $B = \mu$  and  $n = 1$**

This graph shows how  $\mu$  changes for different fluids.

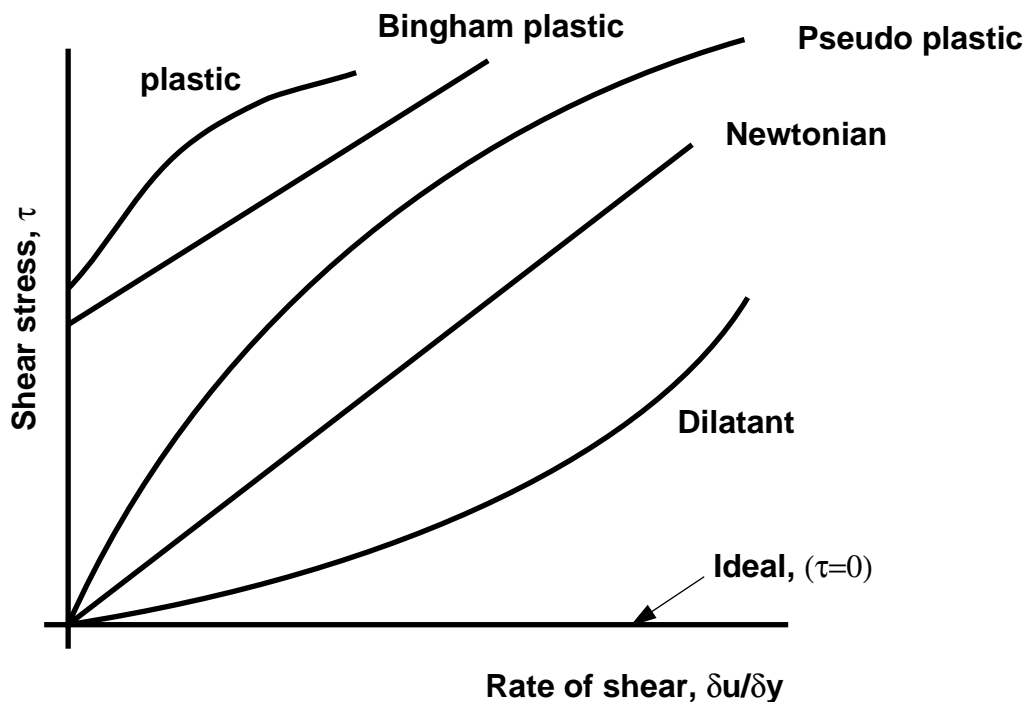

- **Plastic:** Shear stress must reach a certain minimum before flow commences.
- **Bingham plastic:** As with the plastic above a minimum shear stress must be achieved. With this classification  $n = 1$ . An example is sewage sludge.
- **Pseudo-plastic:** No minimum shear stress necessary and the viscosity decreases with rate of shear, e.g. colloidal substances like clay, milk and cement.
- **Dilatant substances;** Viscosity increases with rate of shear e.g. quicksand.
- **Thixotropic substances:** Viscosity decreases with length of time shear force is applied e.g. thixotropic jelly paints.
- **Rheopectic substances:** Viscosity increases with length of time shear force is applied
- **Viscoelastic materials:** Similar to Newtonian but if there is a sudden large change in shear they behave like plastic

## Viscosity

There are two ways of expressing viscosity

## Coefficient of Dynamic Viscosity

$$\mu = \frac{\tau}{du/dy}$$

Units: N s/m<sup>2</sup> or Pa s or kg/m s

The unit Poise is also used where 10 P = 1 Pa·s

Water  $\mu = 8.94 \times 10^{-4}$  Pa s

Mercury  $\mu = 1.526 \times 10^{-3}$  Pa s

Olive oil  $\mu = .081$  Pa s

Pitch  $\mu = 2.3 \times 10^8$  Pa s

Honey  $\mu = 2000 - 10000$  Pa s

Ketchup  $\mu = 50000 - 100000$  Pa s (non-newtonian)

## Kinematic Viscosity

$\nu$  = the ratio of dynamic viscosity to mass density

$$\nu = \frac{\mu}{\rho}$$

Units m<sup>2</sup>/s

Water  $\nu = 1.7 \times 10^{-6}$  m<sup>2</sup>/s.

Air  $\nu = 1.5 \times 10^{-5}$  m<sup>2</sup>/s.

## Flow rate

### Mass flow rate

$$\dot{m} = \frac{dm}{dt} = \frac{\text{mass}}{\text{time taken to accumulate this mass}}$$

A simple example:

An empty bucket weighs 2.0kg. After 7 seconds of collecting water the bucket weighs 8.0kg, then:

$$\begin{aligned} \text{mass flow rate} = \dot{m} &= \frac{\text{mass of fluid in bucket}}{\text{time taken to collect the fluid}} \\ &= \frac{8.0 - 2.0}{7} \\ &= 0.857 \text{ kg / s} \end{aligned}$$

## Volume flow rate - Discharge.

More commonly we use volume flow rate

Also known as *discharge*.

The symbol normally used for discharge is  $Q$ .

$$\text{discharge, } Q = \frac{\text{volume of fluid}}{\text{time}}$$

A simple example:

If the bucket above fills with 2.0 litres in 25 seconds, what is the discharge?

$$\begin{aligned} Q &= \frac{2.0 \times 10^{-3} \text{ m}^3}{25 \text{ sec}} \\ &= 0.0008 \text{ m}^3 / \text{s} \\ &= 0.8 \text{ l} / \text{s} \end{aligned}$$

## Discharge and mean velocity

If we know the discharge and the diameter of a pipe, we can deduce the mean velocity

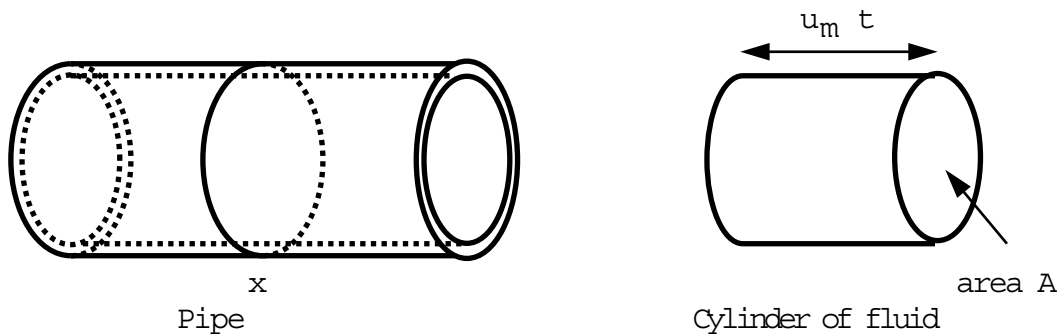

Cross sectional area of pipe is  $A$

Mean velocity is  $u_m$ .

In time  $t$ , a cylinder of fluid will pass point X with a volume  $A \times u_m \times t$ .

The discharge will thus be

$$Q = \frac{\text{volume}}{\text{time}} = \frac{A \times u_m \times t}{t}$$

$$Q = Au_m$$

A simple example:

If  $A = 1.2 \times 10^{-3} \text{ m}^2$

And discharge,  $Q$  is 24 l/s,  
mean velocity is

$$\begin{aligned} u_m &= \frac{Q}{A} \\ &= \frac{2.4 \times 10^{-3}}{1.2 \times 10^{-3}} \\ &= 2.0 \text{ m/s} \end{aligned}$$

Note how we have called this the mean velocity.

This is because the velocity in the pipe is not constant across the cross section.

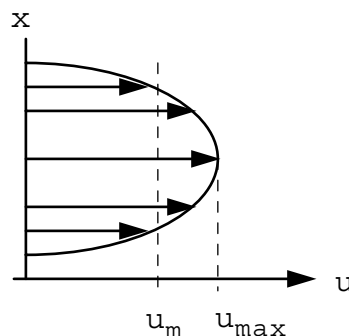

This idea, that mean velocity multiplied by the area gives the discharge, applies to all situations - not just pipe flow.

# Continuity

This principle of *conservation of mass* says matter cannot be created or destroyed

This is applied in fluids to fixed volumes, known as control volumes (or surfaces)

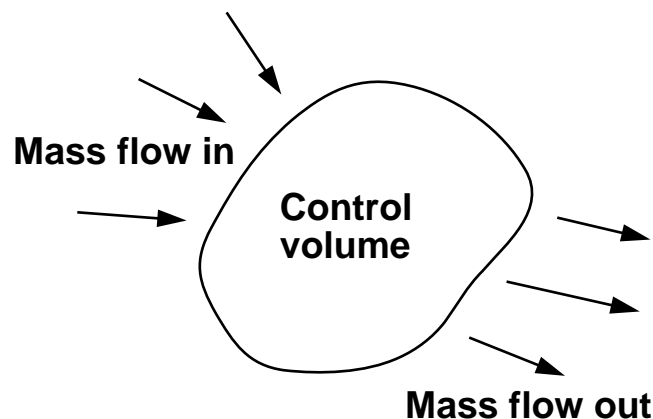

For any control volume the principle of *conservation of mass* says

$$\text{Mass entering per unit time} = \text{Mass leaving per unit time} + \text{Increase of mass in control vol per unit time}$$

For steady flow there is no increase in the mass within the control volume, so

For steady flow

$$\text{Mass entering} = \text{Mass leaving}$$

In a real pipe (or any other vessel) we use the *mean velocity* and write

$$\rho_1 A_1 u_{m1} = \rho_2 A_2 u_{m2} = \text{Constant} = \dot{m}$$

For incompressible, fluid  $\rho_1 = \rho_2 = \rho$   
(dropping the  $m$  subscript)

$$A_1 u_1 = A_2 u_2 = Q$$

This is the continuity equation most often used.

This equation is a **very powerful** tool.

It will be **used repeatedly** throughout the rest of this course.

# **Lecture 3: Examples from** **Unit 1: Fluid Mechanics Basics**

## ***Units***

1.

A water company wants to check that it will have sufficient water if there is a prolonged drought in the area. The region it covers is 500 square miles and various different offices have sent in the following consumption figures. There is sufficient information to calculate the amount of water available, but unfortunately it is in several different units.

Of the total area 100 000 acres are rural land and the rest urban. The density of the urban population is 50 per square kilometre. The average toilet cistern is sized 200mm by 15in by 0.3m and on average each person uses this 3 time per day. The density of the rural population is 5 per square mile. Baths are taken twice a week by each person with the average volume of water in the bath being 6 gallons. Local industry uses 1000 m<sup>3</sup> per week. Other uses are estimated as 5 gallons per person per day. A US air base in the region has given water use figures of 50 US gallons per person per day.

The average rain fall in 1in per month (28 days). In the urban area all of this goes to the river while in the rural area 10% goes to the river 85% is lost (to the aquifer) and the rest goes to the one reservoir which supplies the region. This reservoir has an average surface area of 500 acres and is at a depth of 10 fathoms. 10% of this volume can be used in a month.

- a) What is the total consumption of water per day?
- b) If the reservoir was empty and no water could be taken from the river, would there be enough water if available if rain fall was only 10% of average?

# Fluid Properties

1. The following is a table of measurement for a fluid at constant temperature. Determine the dynamic viscosity of the fluid.

$du/dy$ ( $s^{-1}$ )	0.0	0.2	0.4	0.6	0.8
$\tau$ ( $N\ m^{-2}$ )	0.0	1.0	1.9	3.1	4.0

2. The density of an oil is  $850 \text{ kg/m}^3$ . Find its relative density and Kinematic viscosity if the dynamic viscosity is  $5 \times 10^{-3} \text{ kg/ms}$ .

3. The velocity distribution of a viscous liquid (dynamic viscosity  $\mu = 0.9 \text{ Ns/m}^2$ ) flowing over a fixed plate is given by  $u = 0.68y - y^2$  ( $u$  is velocity in m/s and  $y$  is the distance from the plate in m).  
What are the shear stresses at the plate surface and at  $y=0.34\text{m}$ ?

4.  $5.6\text{m}^3$  of oil weighs 46 800 N. Find its mass density,  $\rho$  and relative density,  $\gamma$ .

5. From table of fluid properties the viscosity of water is given as 0.01008 poises. What is this value in  $\text{Ns/m}^2$  and Pa s units?

6. In a fluid the velocity measured at a distance of 75mm from the boundary is 1.125m/s. The fluid has absolute viscosity 0.048 Pa s and relative density 0.913. What is the velocity gradient and shear stress at the boundary assuming a linear velocity distribution.

# Continuity

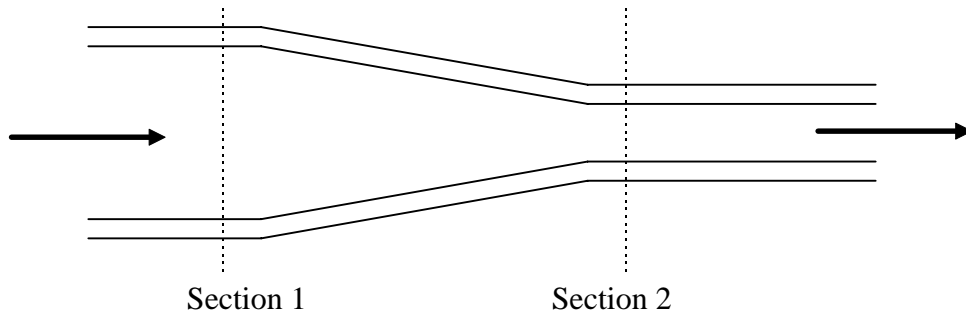

A liquid is flowing from left to right.

**By continuity**

$$A_1 u_1 \rho_1 = A_2 u_2 \rho_2$$

**As we are considering a liquid (incompressible),**

$$\rho_1 = \rho_2 = \rho$$

$$Q_1 = Q_2$$

$$A_1 u_1 = A_2 u_2$$

**If the area  $A_1 = 10 \times 10^{-3} \text{ m}^2$  and  $A_2 = 3 \times 10^{-3} \text{ m}^2$**

**And the upstream mean velocity  $u_1 = 2.1 \text{ m/s}$ .**

**What is the downstream mean velocity?**

Now try this on a *diffuser*, a pipe which expands or diverges as in the figure below,

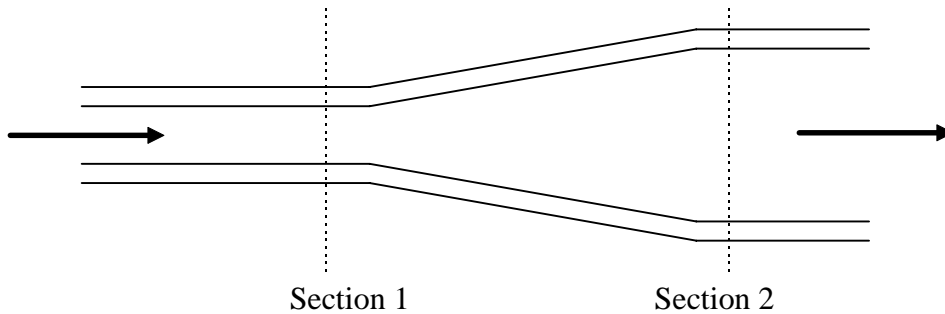

If  $d_1=30\text{mm}$  and  $d_2=40\text{mm}$  and the velocity  $u_2=3.0\text{m/s}$ .

What is the velocity entering the diffuser?

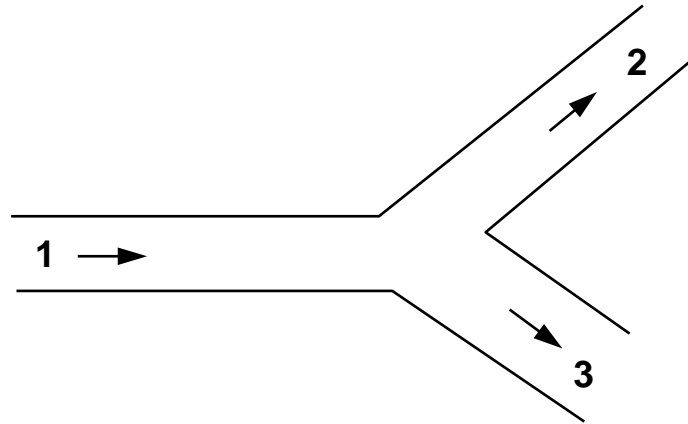
**Velocities in pipes coming from a junction.**

**mass flow into the junction = mass flow out**

$$\rho_1 Q_1 = \rho_2 Q_2 + \rho_3 Q_3$$

**When incompressible**

$$Q_1 = Q_2 + Q_3$$

$$A_1 u_1 = A_2 u_2 + A_3 u_3$$

**If pipe 1 diameter = 50mm, mean velocity 2m/s, pipe 2 diameter 40mm takes 30% of total discharge and pipe 3 diameter 60mm. What are the values of discharge and mean velocity in each pipe?**

## Pressure And Head

We have the vertical pressure relationship

$$\frac{dp}{dz} = -\rho g,$$

integrating gives

$$p = -\rho g z + \text{constant}$$

measuring  $z$  from the free surface so that  $z = -h$

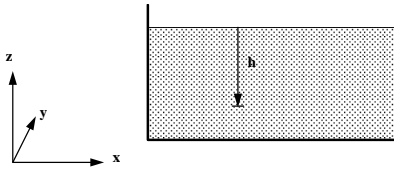

$$p = \rho g h + \text{constant}$$

surface pressure is atmospheric,  $p_{\text{atmospheric}}$

$$p_{\text{atmospheric}} = \text{constant}$$

so

$$p = \rho g h + p_{\text{atmospheric}}$$

It is convenient to take atmospheric pressure as the datum

Pressure quoted in this way is known as gauge pressure i.e.

Gauge pressure is

$$p_{\text{gauge}} = \rho g h$$

The lower limit of any pressure is the pressure in a perfect vacuum.

Pressure measured above a perfect vacuum (zero) is known as absolute pressure

Absolute pressure is

$$p_{\text{absolute}} = \rho g h + p_{\text{atmospheric}}$$

$$\text{Absolute pressure} = \text{Gauge pressure} + \text{Atmospheric}$$

A gauge pressure can be given using height of *any* fluid.

$$p = \rho g h$$

This vertical height is the **head**.

If pressure is quoted in **head**, the density of the fluid **must** also be given.

Example:

What is a pressure of  $500 \text{ kNm}^{-2}$  in head of water of density,  $\rho = 1000 \text{ kgm}^{-3}$

Use  $p = \rho g h$ ,

$$h = \frac{p}{\rho g} = \frac{500 \times 10^3}{1000 \times 9.81} = 50.95 \text{ m of water}$$

In head of Mercury density  $\rho = 13.6 \times 10^3 \text{ kgm}^{-3}$ .

$$h = \frac{500 \times 10^3}{13.6 \times 10^3 \times 9.81} = 3.75 \text{ m of Mercury}$$

In head of a fluid with relative density  $\gamma = 8.7$ .

(remember  $\rho = \gamma \times \rho_{\text{water}}$ )

$$h = \frac{500 \times 10^3}{(8.7 \times 1000) \times 9.81} = 5.86 \text{ m of fluid } \gamma = 8.7$$

## Pressure Measurement By Manometer

Manometers use the relationship between pressure and head to measure pressure

### The Piezometer Tube Manometer

The simplest manometer is an open tube. This is attached to the top of a container with liquid at pressure. containing liquid at a pressure.

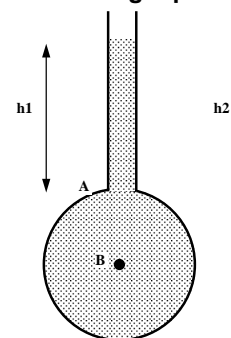

The tube is open to the atmosphere, The pressure measured is relative to atmospheric so it measures **gauge pressure**.

Pressure at A = pressure due to column of liquid  $h_1$

$$p_A = \rho g h_1$$

Pressure at B = pressure due to column of liquid  $h_2$

$$p_B = \rho g h_2$$

**Problems with the Piezometer:**

1. Can only be used for liquids
2. Pressure must above atmospheric
3. Liquid height must be convenient  
i.e. not be too small or too large.

**Equality Of Pressure At The Same Level In A Static Fluid**

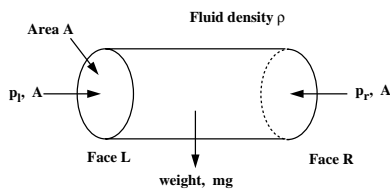

- Horizontal cylindrical element
- cross sectional area =  $A$
- mass density =  $\rho$
- left end pressure =  $p_l$
- right end pressure =  $p_r$

For equilibrium the sum of the forces in the x direction is zero.

$$p_l A = p_r A$$

$$p_l = p_r$$

Pressure in the horizontal direction is constant.

This true for any *continuous* fluid.

**An Example of a Piezometer.**

What is the maximum gauge pressure of water that can be measured by a Piezometer of height 1.5m?

And if the liquid had a relative density of 8.5 what would the maximum measurable gauge pressure?

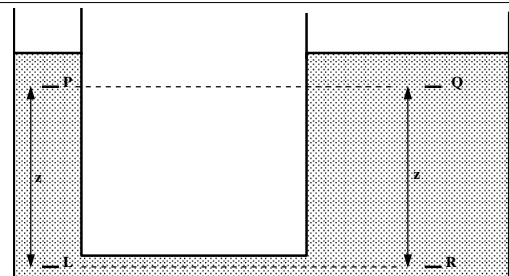

We have shown

$$p_l = p_r$$

For a vertical pressure change we have

$$p_l = p_p + \rho g z$$

and

$$p_r = p_q + \rho g z$$

so

$$p_p + \rho g z = p_q + \rho g z$$

$$p_p = p_q$$

Pressure at the two equal levels are the same.

## The "U"-Tube Manometer

"U"-Tube enables the pressure of both liquids and gases to be measured

"U" is connected as shown and filled with *manometric fluid*.

Important points:

1. The manometric fluid density should be greater than of the fluid measured.

$$\rho_{man} > \rho$$

2. The two fluids should not be able to mix they must be immiscible.

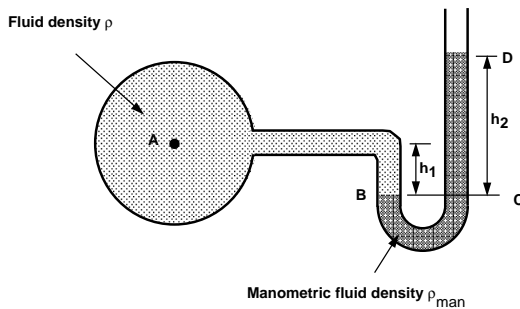

## We know:

Pressure in a continuous static fluid is the same at any horizontal level.

$$\text{pressure at } B = \text{pressure at } C$$

$$\rho_B = \rho_C$$

For the left hand arm

pressure at B = pressure at A + pressure of height of liquid being measured

$$\rho_B = \rho_A + \rho g h_1$$

For the right hand arm

pressure at C = pressure at D + pressure of height of manometric liquid

$$\rho_C = \rho_{atmospheric} + \rho_{man} g h_2$$

We are measuring *gauge pressure* we can subtract  $\rho_{atmospheric}$  giving

$$\rho_B = \rho_C$$

$$\rho_A = \rho_{man} g h_2 - \rho g h_1$$

## What if the fluid is a gas?

Nothing changes.

The manometer work exactly the same.

BUT:

As the manometric fluid is liquid (usually mercury, oil or water)

And Liquid density is much greater than gas,

$$\rho_{man} \gg \rho$$

$\rho g h_1$  can be neglected,

and the gauge pressure given by

$$\rho_A = \rho_{man} g h_2$$

## An example of the U-Tube manometer.

Using a u-tube manometer to measure gauge pressure of fluid density  $\rho = 700 \text{ kg/m}^3$ , and the manometric fluid is mercury, with a relative density of 13.6.

What is the gauge pressure if:

- a)  $h_1 = 0.4\text{m}$  and  $h_2 = 0.9\text{m}$ ?
- b)  $h_1$  stayed the same but  $h_2 = -0.1\text{m}$ ?

### Pressure difference measurement Using a "U"-Tube Manometer.

The "U"-tube manometer can be connected at both ends to measure *pressure difference* between these two points

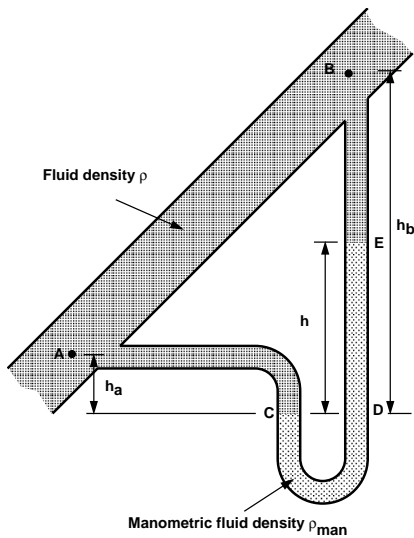

*pressure at C = pressure at D*

$$p_C = p_D$$

$$p_C = p_A + \rho g h_a$$

$$p_D = p_B + \rho g (h_b + h) + \rho_{man} g h$$

$$p_A + \rho g h_a = p_B + \rho g (h_b + h) + \rho_{man} g h$$

Giving the pressure difference

$$p_A - p_B = \rho g (h_b - h_a) + (\rho_{man} - \rho) g h$$

Again if the fluid is a gas  $\rho_{man} \gg \rho$ , then the terms involving  $\rho$  can be neglected,

$$p_A - p_B = \rho_{man} g h$$

### An example using the u-tube for pressure difference measuring

In the figure below two pipes containing the same fluid of density  $\rho = 990 \text{ kg/m}^3$  are connected using a u-tube manometer.

What is the pressure between the two pipes if the manometer contains fluid of relative density 13.6?

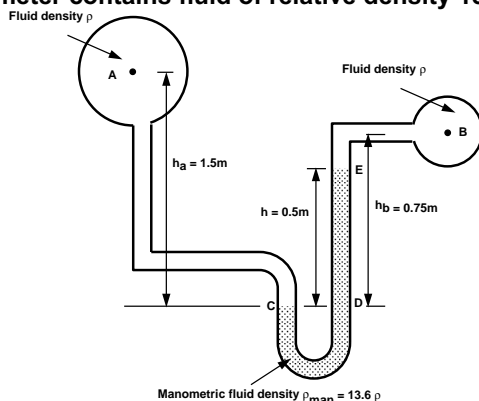

### Advances to the "U" tube manometer

**Problem:** Two readings are required.

**Solution:** Increase cross-sectional area of one side.

**Result:** One level moves much more than the other.

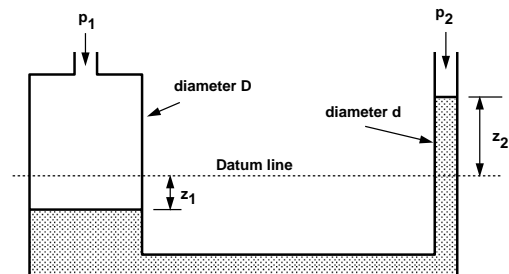

If the manometer is measuring the pressure difference of a gas of  $(p_1 - p_2)$  as shown, we know

$$p_1 - p_2 = \rho_{man} g h$$

volume of liquid moved from  
the left side to the right

$$= z_2 \times (\pi d^2 / 4)$$

The fall in level of the left side is

$$\begin{aligned} z_1 &= \frac{\text{Volume moved}}{\text{Area of left side}} \\ &= \frac{z_2 (\pi d^2 / 4)}{\pi D^2 / 4} \\ &= z_2 \left( \frac{d}{D} \right)^2 \end{aligned}$$

Putting this in the equation,

$$\begin{aligned} p_1 - p_2 &= \rho g \left[ z_2 + z_2 \left( \frac{d}{D} \right)^2 \right] \\ &= \rho g z_2 \left[ 1 + \left( \frac{d}{D} \right)^2 \right] \end{aligned}$$

If  $D \gg d$  then  $(d/D)^2$  is very small so

$$p_1 - p_2 = \rho g z_2$$

**Problem:** Small pressure difference,  
movement cannot be read.

**Solution 1:** Reduce density of manometric  
fluid.

**Result:** Greater height change -  
easier to read.

**Solution 2:** Tilt one arm of the manometer.

**Result:** Same height change - but larger  
movement along the  
manometer arm - easier to read.

### Inclined manometer

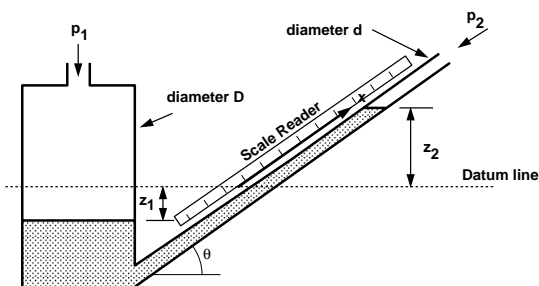

The pressure difference is still given by the  
height change of the manometric fluid.

$$p_1 - p_2 = \rho g z_2$$

but,

$$z_2 = x \sin \theta$$

$$p_1 - p_2 = \rho g x \sin \theta$$

The sensitivity to pressure change can be increased  
further by a greater inclination.

#### Example of an inclined manometer.

An inclined manometer is required to measure an air  
pressure of 3mm of water to an accuracy of +/- 3%.  
The inclined arm is 8mm in diameter and the larger  
arm has a diameter of 24mm. The manometric fluid  
has density  $\rho_{\text{man}} = 740 \text{ kg/m}^3$  and the scale may be  
read to +/- 0.5mm.

What is the angle required to ensure the desired  
accuracy may be achieved?

## Choice Of Manometer

Take care when fixing the manometer to vessel  
Burrs cause local pressure variations.

### Disadvantages:

- Slow response - only really useful for very slowly varying pressures - no use at all for fluctuating pressures;
- For the "U" tube manometer two measurements must be taken simultaneously to get the h value.
- It is often difficult to measure small variations in pressure.
- It cannot be used for very large pressures unless several manometers are connected in series;
- For very accurate work the temperature and relationship between temperature and  $\rho$  must be known;

### Advantages of manometers:

- They are very simple.
- No calibration is required - the pressure can be calculated from first principles.

## Forces on Submerged Surfaces in Static Fluids

We have seen these features of static fluids

- Hydrostatic vertical pressure distribution
- Pressures at any equal depths in a continuous fluid are equal
- Pressure at a point acts equally in all directions (Pascal's law).
- Forces from a fluid on a boundary acts at right angles to that boundary.

### Fluid pressure on a surface

Pressure is force per unit area.

Pressure  $p$  acting on a small area  $\delta A$  exerted force will be

$$F = p \times \delta A$$

Since the fluid is at rest the force will act at right-angles to the surface.

### General submerged plane

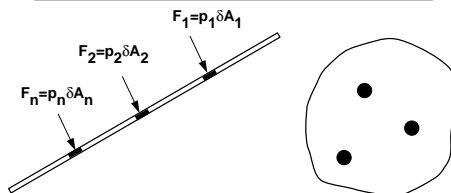

The total or *resultant* force,  $R$ , on the plane is the sum of the forces on the small elements i.e.

$$R = p_1 \delta A_1 + p_2 \delta A_2 + \dots + p_n \delta A_n = \sum p \delta A$$

and

This resultant force will act through the *centre of pressure*.

For a plane surface all forces acting can be represented by one single *resultant force*, acting at right-angles to the plane through the *centre of pressure*.

### Horizontal submerged plane

The pressure,  $p$ , will be equal at all points of the surface.

The resultant force will be given by

$$R = \text{pressure} \times \text{area of plane}$$

$$R = pA$$

### Curved submerged surface

Each elemental force is a different magnitude and in a different direction (but still normal to the surface.).

It is, in general, not easy to calculate the resultant force for a curved surface by combining all elemental forces.

The sum of all the forces on each element will always be less than the sum of the individual forces,  $\sum p \delta A$ .

### Resultant Force and Centre of Pressure on a general plane surface in a liquid.

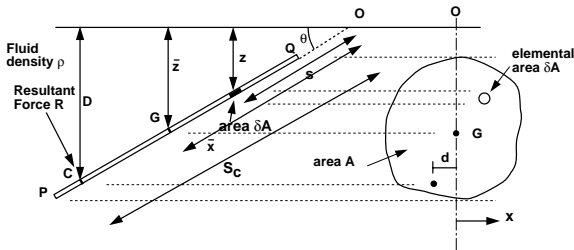

Take pressure as zero at the surface.

Measuring down from the surface, the pressure on an element  $\delta A$ , depth  $z$ ,

$$p = \rho g z$$

So force on element

$$F = \rho g z \delta A$$

Resultant force on plane

$$R = \rho g \sum z \delta A$$

(assuming  $\rho$  and  $g$  as constant).

$\sum z \delta A$  is known as

the **1<sup>st</sup> Moment of Area** of the plane PQ about the free surface.

And it is known that

$$\sum z \delta A = A \bar{z}$$

$A$  is the area of the plane

$\bar{z}$  is the distance to the **centre of gravity (centroid)**

In terms of distance from point O

$$\sum z \delta A = A \bar{x} \sin \theta$$

= 1<sup>st</sup> moment of area  $\times \sin \theta$   
about a line through O

(as  $\bar{z} = \bar{x} \sin \theta$ )

The resultant force on a plane

$$R = \rho g A \bar{z}$$

$$= \rho g A \bar{x} \sin \theta$$

This resultant force acts at right angles through the centre of pressure, C, at a depth D.

How do we find this position?

Take moments of the forces.

As the plane is in equilibrium:

The moment of  $R$  will be equal to the sum of the moments of the forces on all the elements  $\delta A$  about the same point.

It is convenient to take moment about O

The force on each elemental area:

$$\text{Force on } \delta A = \rho g z \delta A$$

$$= \rho g s \sin \theta \delta A$$

the moment of this force is:

$$\text{Moment of Force on } \delta A \text{ about O} = \rho g s \sin \theta \delta A \times s$$

$$= \rho g \sin \theta \delta A s^2$$

$\rho$ ,  $g$  and  $\theta$  are the same for each element, giving the total moment as

Sum of moments =  $\rho g \sin \theta \sum s^2 \delta A$

Moment of R about O =  $R \times S_c = \rho g A \bar{x} \sin \theta S_c$

Equating

$$\rho g A \bar{x} \sin \theta S_c = \rho g \sin \theta \sum s^2 \delta A$$

The position of the centre of pressure along the plane measure from the point O is:

$$S_c = \frac{\sum s^2 \delta A}{A \bar{x}}$$

How do we work out the summation term?

This term is known as the **2<sup>nd</sup> Moment of Area,  $I_o$** ,

of the plane  
(about the axis through O)

$$2^{\text{nd}} \text{ moment of area about } O = I_o = \sum s^2 \delta A$$

It can be easily calculated for many common shapes.

The position of the *centre of pressure* along the plane measure from the point O is:

$$S_c = \frac{2^{\text{nd}} \text{ Moment of area about a line through } O}{1^{\text{st}} \text{ Moment of area about a line through } O}$$

and

Depth to the *centre of pressure* is

$$D = S_c \sin \theta$$

The *parallel axis theorem* can be written

$$I_o = I_{GG} + A\bar{x}^2$$

We then get the following equation for the position of the centre of pressure

$$S_c = \frac{I_{GG}}{A\bar{x}} + \bar{x}$$

$$D = \sin \theta \left( \frac{I_{GG}}{A\bar{x}} + \bar{x} \right)$$

(In the examination the parallel axis theorem and the  $I_{GG}$  will be given)

## How do you calculate the 2<sup>nd</sup> moment of area?

2<sup>nd</sup> moment of area is a geometric property.

It can be found from tables - BUT only for moments about an axis through its centroid =  $I_{GG}$ .

Usually we want the 2<sup>nd</sup> moment of area about a different axis.

Through O in the above examples.

We can use the parallel axis theorem to give us what we want.

The 2<sup>nd</sup> moment of area about a line through the centroid of some common shapes.

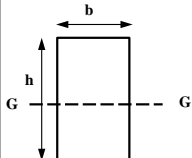
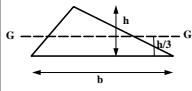
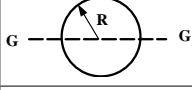
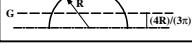
Shape	Area A	2 <sup>nd</sup> moment of area, $I_{GG}$ , about an axis through the centroid
Rectangle 	$bd$	$\frac{bd^3}{12}$
Triangle 	$\frac{bd}{2}$	$\frac{bd^3}{36}$
Circle 	$\pi R^2$	$\frac{\pi R^4}{4}$
Semicircle 	$\frac{\pi R^2}{2}$	$0.1102 R^4$

**An example:**

Find the moment required to keep this triangular gate closed on a tank which holds water.

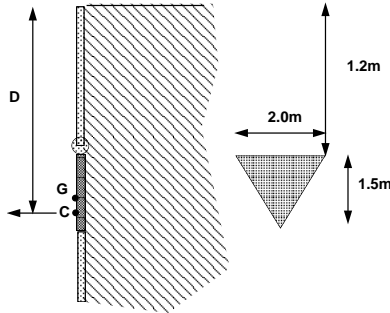

### Submerged vertical surface - Pressure diagrams

For vertical walls of constant width it is possible to find the resultant force and centre of pressure graphically using a *pressure diagram*.

We know the relationship between pressure and depth:

$$p = \rho g z$$

So we can draw the diagram below:

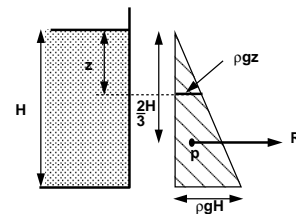

This is known as a *pressure diagram*.

Pressure increases from zero at the surface linearly by  $p = \rho g z$ , to a maximum at the base of  $p = \rho g H$ .

The *area* of this triangle represents the *resultant force per unit width* on the vertical wall,

Units of this are Newtons per metre.

$$\begin{aligned} \text{Area} &= \frac{1}{2} \times AB \times BC \\ &= \frac{1}{2} H \rho g H \\ &= \frac{1}{2} \rho g H^2 \end{aligned}$$

**Resultant force per unit width**

$$R = \frac{1}{2} \rho g H^2 \quad (N / m)$$

The force acts through the *centroid of the pressure diagram*.

For a triangle the centroid is at  $2/3$  its height i.e. the resultant force acts horizontally through the point  $z = \frac{2}{3} H$ .

For a vertical plane the depth to the centre of pressure is given by

$$D = \frac{2}{3} H$$

**Check this against the moment method:**

The resultant force is given by:

$$R = \rho g A \bar{z} = \rho g A \bar{x} \sin \theta$$

$$= \rho g (H \times 1) \frac{H}{2} \sin \theta$$

$$= \frac{1}{2} \rho g H^2$$

and the depth to the centre of pressure by:

$$D = \sin \theta \left( \frac{I_o}{A \bar{x}} \right)$$

and by the parallel axis theorem (with width of 1)

$$I_o = I_{GG} + A \bar{x}^2$$

$$= \frac{1 \times H^3}{12} + 1 \times H \left( \frac{H}{2} \right)^2 = \frac{H^3}{3}$$

Depth to the centre of pressure

$$D = \left( \frac{H^3 / 3}{H^2 / 2} \right) = \frac{2}{3} H$$

**Submerged Curved Surface**

If the surface is curved the resultant force must be found by combining the elemental forces using some vectorial method.

**Calculate the horizontal and vertical components.**

**Combine these to obtain the resultant force and direction.**

(Although this can be done for all three dimensions we will only look at one vertical plane)

The same technique can be used with combinations of liquids are held in tanks (e.g. oil floating on water). For example:

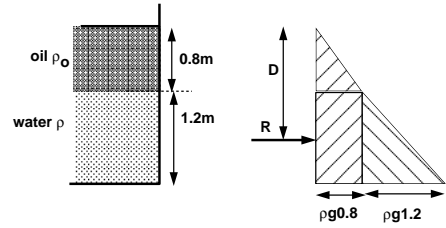

Find the position and magnitude of the resultant force on this vertical wall of a tank which has oil floating on water as shown.

In the diagram below liquid is resting on top of a curved base.

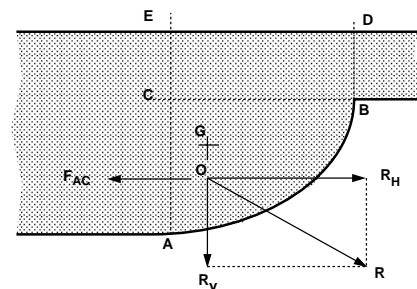

The fluid is at rest – in equilibrium.

So any element of fluid such as ABC is also in equilibrium.

## Consider the Horizontal forces

The sum of the horizontal forces is zero.

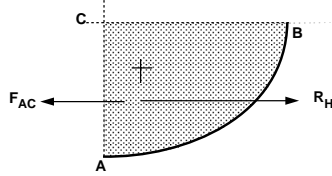

No horizontal force on CB as there are no shear forces in a static fluid

Horizontal forces act only on the faces AC and AB as shown.

$F_{AC}$  must be equal and opposite to  $R_H$ .

AC is the projection of the curved surface AB onto a vertical plane.

The resultant horizontal force of a fluid above a curved surface is:

$R_H$  = Resultant force on the projection of the curved surface onto a vertical plane.

We know

1. The force on a vertical plane must act horizontally (as it acts normal to the plane).
2. That  $R_H$  must act through the same point.

So:

$R_H$  acts horizontally through the centre of pressure of the projection of the curved surface onto an vertical plane.

We have seen earlier how to calculate resultant forces and point of action.

Hence we can calculate the resultant horizontal force on a curved surface.

## Consider the Vertical forces

The sum of the vertical forces is zero.

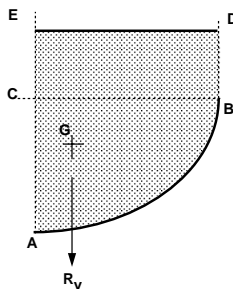

There are no shear force on the vertical edges, so the vertical component can only be due to the *weight of the fluid*.

So we can say

The resultant vertical force of a fluid above a curved surface is:

$R_V$  = Weight of fluid directly above the curved surface.

It will act vertically down through the centre of gravity of the mass of fluid.

## Resultant force

The overall resultant force is found by combining the vertical and horizontal components vectorially,

Resultant force

$$R = \sqrt{R_H^2 + R_V^2}$$

And acts through O at an angle of  $\theta$ .

The angle the resultant force makes to the horizontal is

$$\theta = \tan^{-1}\left(\frac{R_V}{R_H}\right)$$

The position of O is the point of intersection of the horizontal line of action of  $R_H$  and the vertical line of action of  $R_V$ .

A typical example application of this is the determination of the forces on dam walls or curved sluice gates.

Find the magnitude and direction of the resultant force of water on a quadrant gate as shown below.

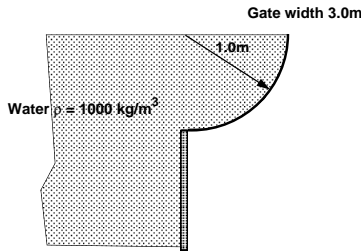

**Horizontal force**

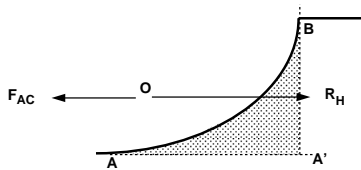

The two horizontal on the element are:  
 The horizontal reaction force  $R_H$   
 The force on the vertical plane  $A'B$ .

The resultant horizontal force,  $R_H$  acts as shown in the diagram. Thus we can say:

The resultant horizontal force of a fluid below a curved surface is:  
 $R_H$  = Resultant force on the projection of the curved surface onto a vertical plane.

**What are the forces if the fluid is below the curved surface?**

This situation may occur on a curved sluice gate.

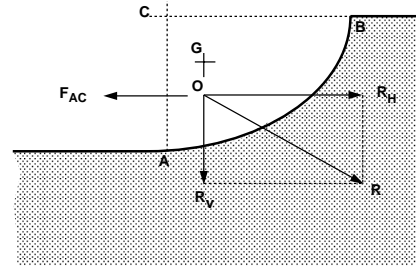

The force calculation is very similar to when the fluid is above.

**Vertical force**

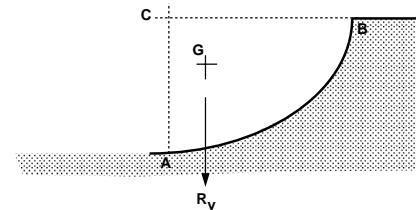

What vertical force would keep this in equilibrium?

If the region above the curve were all water there would be equilibrium.

Hence: the force exerted by this amount of fluid must equal the resultant force.

The resultant vertical force of a fluid below a curved surface is:  
 $R_V$  = Weight of the *imaginary* volume of fluid vertically above the curved surface.

The resultant force and direction of application are calculated in the same way as for fluids above the surface:

Resultant force

$$R = \sqrt{R_H^2 + R_V^2}$$

And acts through O at an angle of  $\theta$ .

The angle the resultant force makes to the horizontal is

$$\theta = \tan^{-1}\left(\frac{R_V}{R_H}\right)$$

An example of a curved sluice gate which experiences force from fluid below.

A 1.5m long cylinder lies as shown in the figure, holding back oil of relative density 0.8. If the cylinder has a mass of 2250 kg find

a) the reaction at A      b) the reaction at B

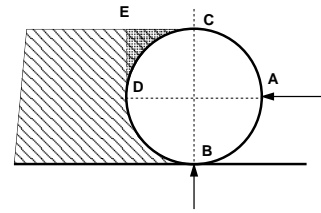

**CIVE1400: An Introduction to Fluid Mechanics****Unit 3: Fluid Dynamics**

Dr P A Sleigh: P.A.Sleigh@leeds.ac.uk  
 Dr C J Noakes: C.J.Noakes@leeds.ac.uk

January 2008

Module web site: [www.efm.leeds.ac.uk/CIVE/FluidsLevel1](http://www.efm.leeds.ac.uk/CIVE/FluidsLevel1)

Unit 1: Fluid Mechanics Basics 3 lectures  
 Flow  
 Pressure  
 Properties of Fluids  
 Fluids vs. Solids  
 Viscosity

Unit 2: Statics 3 lectures  
 Hydrostatic pressure  
 Manometry / Pressure measurement  
 Hydrostatic forces on submerged surfaces

Unit 3: Dynamics 7 lectures  
 The continuity equation.  
 The Bernoulli Equation.  
 Application of Bernoulli equation.  
 The momentum equation.  
 Application of momentum equation.

Unit 4: Effect of the boundary on flow 4 lectures  
 Laminar and turbulent flow  
 Boundary layer theory  
 An Intro to Dimensional analysis  
 Similarity

**Fluid Dynamics****Objectives**

1. Identify differences between:
  - steady/unsteady
  - uniform/non-uniform
  - compressible/incompressible flow
2. Demonstrate streamlines and stream tubes
3. Introduce the Continuity principle
4. Derive the Bernoulli (energy) equation
5. Use the continuity equations to predict pressure and velocity in flowing fluids
6. Introduce the momentum equation for a fluid
7. Demonstrate use of the momentum equation to predict forces induced by flowing fluids

**Fluid dynamics:**

The analysis of fluid in motion

Fluid motion can be predicted in the same way as the motion of solids

By use of the fundamental laws of physics and the physical properties of the fluid

Some fluid flow is very complex:

e.g.

- Spray behind a car
- waves on beaches;
- hurricanes and tornadoes
- any other atmospheric phenomenon

All can be analysed with varying degrees of success (in some cases hardly at all!).

There are many common situations which analysis gives very accurate predictions

**Flow Classification**

Fluid flow may be classified under the following headings

uniform:

Flow conditions (velocity, pressure, cross-section or depth) are the same at every point in the fluid.

non-uniform:

Flow conditions are not the same at every point.

steady

Flow conditions may differ from point to point but DO NOT change with time.

unsteady

Flow conditions change with time at any point.

Fluid flowing under normal circumstances - a river for example - conditions vary from point to point we have non-uniform flow.

If the conditions at one point vary as time passes then we have unsteady flow.

## Combining these four gives..

### Steady uniform flow.

Conditions do not change with position in the stream or with time.

E.g. flow of water in a pipe of constant diameter at constant velocity.

### Steady non-uniform flow.

Conditions change from point to point in the stream but do not change with time.

E.g. Flow in a tapering pipe with constant velocity at the inlet.

### Unsteady uniform flow.

At a given instant in time the conditions at every point are the same, but will change with time.

E.g. A pipe of constant diameter connected to a pump pumping at a constant rate which is then switched off.

### Unsteady non-uniform flow

Every condition of the flow may change from point to point and with time at every point.

E.g. Waves in a channel.

*This course is restricted to Steady uniform flow - the most simple of the four.*

## Compressible or Incompressible Flow?

All fluids are compressible - even water.  
Density will change as pressure changes.

Under steady conditions

- provided that changes in pressure are *small* - we usually say the fluid is incompressible
- it has constant density.

## Three-dimensional flow

In general fluid flow is three-dimensional.

Pressures and velocities change in all directions.

In many cases the greatest changes only occur in two directions or even only in one.

Changes in the other direction can be effectively ignored making analysis much more simple.

## One dimensional flow:

Conditions vary only in the direction of flow not across the cross-section.

The flow may be unsteady with the parameters varying in time but not across the cross-section.

E.g. Flow in a pipe.

### But:

Since flow must be zero at the pipe wall - yet non-zero in the centre - there is a difference of parameters across the cross-section.

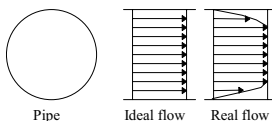

Should this be treated as two-dimensional flow?

Possibly - but it is only necessary if very high accuracy is required.

## Two-dimensional flow

Conditions vary in the direction of flow and in one direction at right angles to this.

Flow patterns in two-dimensional flow can be shown by curved lines on a plane.

Below shows flow pattern over a weir.

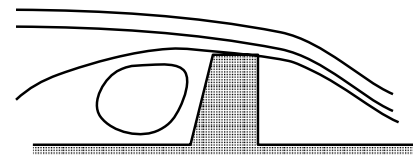

In this course we will be considering:

- steady
- incompressible
- one and two-dimensional flow

## Streamlines

It is useful to visualise the flow pattern.  
Lines joining points of equal velocity - velocity contours - can be drawn.

These lines are known as streamlines

Here are 2-D streamlines around a cross-section of an aircraft wing shaped body:

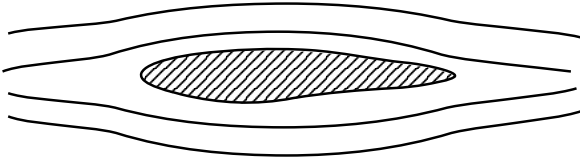

Fluid flowing past a solid boundary does not flow into or out of the solid surface.

Very close to a boundary wall the flow direction must be along the boundary.

## Some points about streamlines:

- Close to a solid boundary, streamlines are parallel to that boundary
- The direction of the streamline is the direction of the fluid velocity
  - Fluid can not cross a streamline
  - Streamlines can not cross each other
- Any particles starting on one streamline will stay on that same streamline
- In unsteady flow streamlines can change position with time
- In steady flow, the position of streamlines does not change.

## Streamtubes

A circle of points in a flowing fluid each has a streamline passing through it.

These streamlines make a tube-like shape known as a streamtube

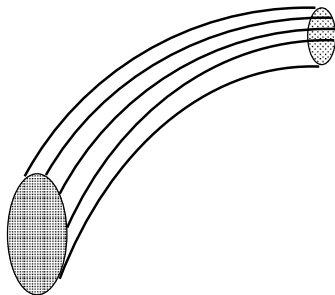

In a two-dimensional flow the streamtube is flat (in the plane of the paper):

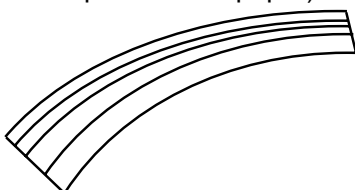

## Some points about streamtubes

- The “walls” of a streamtube are streamlines.
- Fluid cannot flow across a streamline, so fluid cannot cross a streamtube “wall”.
  - A streamtube is not like a pipe. Its “walls” move with the fluid.
- In unsteady flow streamtubes can change position with time
- In steady flow, the position of streamtubes does not change.

## Flow rate

### Mass flow rate

$$\dot{m} = \frac{dm}{dt} = \frac{\text{mass}}{\text{time taken to accumulate this mass}}$$

### Volume flow rate - Discharge.

More commonly we use volume flow rate  
Also known as *discharge*.

The symbol normally used for discharge is  $Q$ .

$$\text{discharge, } Q = \frac{\text{volume of fluid}}{\text{time}}$$

## Discharge and mean velocity

Cross sectional area of a pipe is  $A$

Mean velocity is  $u_m$ .

$$Q = Au_m$$

We usually drop the "m" and imply mean velocity.

## Continuity

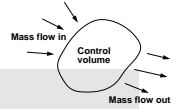

$$\begin{array}{l} \text{Mass entering} = \text{Mass leaving} \quad + \quad \text{Increase} \\ \text{per unit time} \quad \text{per unit time} \quad \quad \text{of mass in} \\ \quad \quad \quad \quad \quad \quad \quad \quad \quad \quad \text{control vol} \\ \quad \quad \quad \quad \quad \quad \quad \quad \quad \quad \text{per unit time} \end{array}$$

For steady flow there is no increase in the mass within the control volume, so

For steady flow

$$\begin{array}{l} \text{Mass entering} = \text{Mass leaving} \\ \text{per unit time} \quad \text{per unit time} \end{array}$$

$$Q_1 = Q_2 = A_1 u_1 = A_2 u_2$$

## Applying to a streamtube:

Mass enters and leaves only through the two ends  
(it cannot cross the streamtube wall).

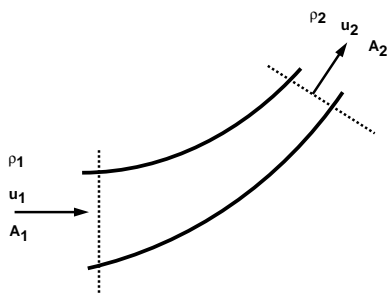

$$\begin{array}{l} \text{Mass entering} = \text{Mass leaving} \\ \text{per unit time} \quad \text{per unit time} \end{array}$$

$$\rho_1 \delta A_1 u_1 = \rho_2 \delta A_2 u_2$$

Or for steady flow,

$$\rho_1 \delta A_1 u_1 = \rho_2 \delta A_2 u_2 = \text{Constant} = \dot{m} = \frac{dm}{dt}$$

This is the continuity equation.

In a real pipe (or any other vessel) we use the *mean* velocity and write

$$\rho_1 A_1 u_{m1} = \rho_2 A_2 u_{m2} = \text{Constant} = \dot{m}$$

For incompressible, fluid  $\rho_1 = \rho_2 = \rho$   
(dropping the  $m$  subscript)

$$A_1 u_1 = A_2 u_2 = Q$$

This is the continuity equation most often used.

This equation is a very powerful tool.  
It will be used repeatedly throughout the rest of this course.

**Some example applications of Continuity**

1. What is the outflow?

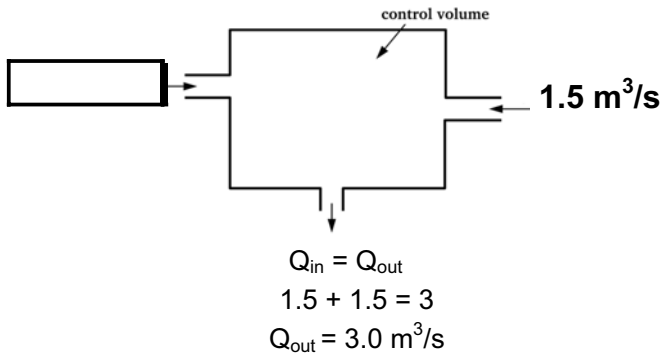

2. What is the inflow?

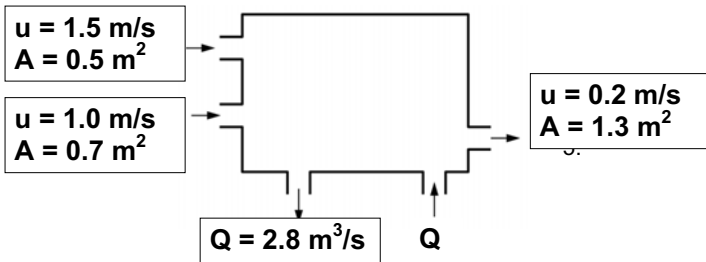

$Q = \text{Area} \times \text{Mean Velocity} = Au$

$Q + 1.5 \times 0.5 + 1 \times 0.7 = 0.2 \times 1.3 + 2.8$   
 $Q = 3.72 \text{ m}^3/\text{s}$

Water flows in a circular pipe which increases in diameter from 400mm at point A to 500mm at point B. Then pipe then splits into two branches of diameters 0.3m and 0.2m discharging at C and D respectively.

If the velocity at A is 1.0m/s and at D is 0.8m/s, what are the discharges at C and D and the velocities at B and C?

**Solution:**

Draw diagram:

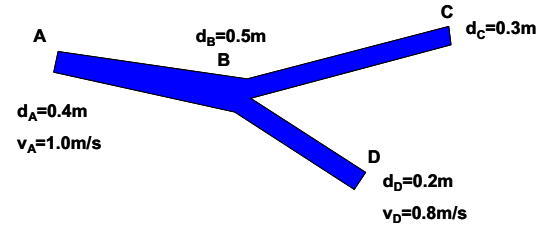

Make a table and fill in the missing values

Point	Velocity m/s	Diameter m	Area m <sup>2</sup>	Q m <sup>3</sup> /s
A	1.00	0.4	0.126	0.126
B	0.64	0.5	0.196	0.126
C	1.42	0.3	0.071	0.101
D	0.80	0.2	0.031	0.025

**Lecture 9: The Bernoulli Equation**  
**Unit 3: Fluid Dynamics**

The Bernoulli equation is a statement of the principle of conservation of energy along a streamline

It can be written:

$$\frac{p_1}{\rho g} + \frac{u_1^2}{2g} + z_1 = H = \text{Constant}$$

These terms represent:

Pressure energy per unit weight + Kinetic energy per unit weight + Potential energy per unit weight = Total energy per unit weight

These term all have units of length, they are often referred to as the following:

pressure head =  $\frac{p}{\rho g}$       velocity head =  $\frac{u^2}{2g}$

potential head =  $z$       total head =  $H$

**Restrictions in application of Bernoulli's equation:**

- Flow is steady
- Density is constant (incompressible)
- Friction losses are negligible
- It relates the states at two points along a single streamline, (not conditions on two different streamlines)

All these conditions are impossible to satisfy at any instant in time!

Fortunately, for many real situations where the conditions are *approximately* satisfied, the equation gives very good results.

**The derivation of Bernoulli's Equation:**

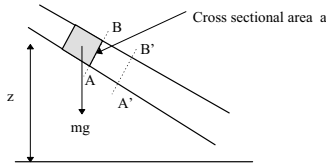

An element of fluid, as that in the figure above, has potential energy due to its height  $z$  above a datum and kinetic energy due to its velocity  $u$ . If the element has weight  $mg$  then

potential energy =  $mgz$

potential energy per unit weight =  $z$

kinetic energy =  $\frac{1}{2}mu^2$

kinetic energy per unit weight =  $\frac{u^2}{2g}$

At any cross-section the pressure generates a force, the fluid will flow, moving the cross-section, so work will be done. If the pressure at cross section AB is  $p$  and the area of the cross-section is  $a$  then

force on AB =  $pa$

when the mass  $mg$  of fluid has passed AB, cross-section AB will have moved to A'B'

volume passing AB =  $\frac{mg}{\rho g} = \frac{m}{\rho}$

therefore

distance AA' =  $\frac{m}{\rho a}$

work done = force  $\times$  distance AA'

=  $pa \times \frac{m}{\rho a} = \frac{pm}{\rho}$

work done per unit weight =  $\frac{p}{\rho g}$

This term is known as the pressure energy of the flowing stream.

Summing all of these energy terms gives

Pressure	Kinetic	Potential	Total
energy per	energy per	energy per	energy per
unit weight	unit weight	unit weight	unit weight

or

$\frac{p}{\rho g} + \frac{u^2}{2g} + z = H$

By the principle of conservation of energy, the total energy in the system does not change, thus the total head does not change. So the Bernoulli equation can be written

$\frac{p}{\rho g} + \frac{u^2}{2g} + z = H = \text{Constant}$

The Bernoulli equation is applied along

like that joining points 1 and 2 below.

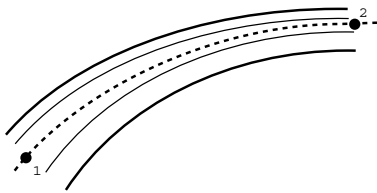

total head at 1 = total head at 2

or

$\frac{p_1}{\rho g} + \frac{u_1^2}{2g} + z_1 = \frac{p_2}{\rho g} + \frac{u_2^2}{2g} + z_2$

This equation assumes no energy losses (e.g. from friction) or energy gains (e.g. from a pump) along the streamline. It can be expanded to include these simply, by adding the appropriate energy terms:

Total	Total	Loss	Work done	Energy
energy per	energy per unit	per unit	per unit	supplied
unit weight at 1	weight at 2	weight	weight	per unit weight

$\frac{p_1}{\rho g} + \frac{u_1^2}{2g} + z_1 = \frac{p_2}{\rho g} + \frac{u_2^2}{2g} + z_2 + h + w - q$

**Practical use of the Bernoulli Equation**

The Bernoulli equation is often combined with the continuity equation to find velocities and pressures at points in the flow connected by a streamline.

Example:

Finding pressures and velocities within a contracting and expanding pipe.

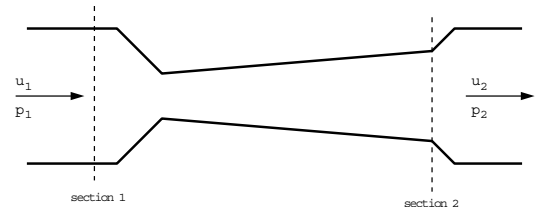

A fluid, density  $\rho = 960 \text{ kg/m}^3$  is flowing steadily through the above tube.

The section diameters are  $d_1=100\text{mm}$  and  $d_2=80\text{mm}$ .

The gauge pressure at 1 is  $p_1=200\text{kN/m}^2$

The velocity at 1 is  $u_1=5\text{m/s}$ .

The tube is horizontal ( $z_1=z_2$ )

What is the gauge pressure at section 2?

Apply the Bernoulli equation along a streamline joining section 1 with section 2.

$$\frac{p_1}{\rho g} + \frac{u_1^2}{2g} + z_1 = \frac{p_2}{\rho g} + \frac{u_2^2}{2g} + z_2$$

$$p_2 = p_1 + \frac{\rho}{2}(u_1^2 - u_2^2)$$

Use the continuity equation to find  $u_2$

$$A_1 u_1 = A_2 u_2$$

$$u_2 = \frac{A_1 u_1}{A_2} = \left(\frac{d_1}{d_2}\right)^2 u_1$$

$$= 7.8125 \text{ m/s}$$

So pressure at section 2

$$p_2 = 200000 - 17296.87$$

$$= 182703 \text{ N/m}^2$$

$$= 182.7 \text{ kN/m}^2$$

Note how

the velocity has increased  
the pressure has decreased

We have used both the Bernoulli equation and the Continuity principle together to solve the problem.

Use of this combination is very common. We will be seeing this again frequently throughout the rest of the course.

### Applications of the Bernoulli Equation

The Bernoulli equation is applicable to many situations not just the pipe flow.

Here we will see its application to flow measurement from tanks, within pipes as well as in open channels.

### Applications of Bernoulli: Flow from Tanks Flow Through A Small Orifice

Flow from a tank through a hole in the side.

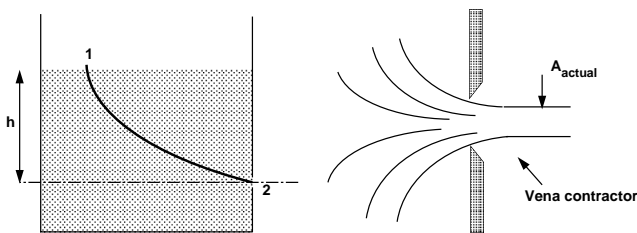

The edges of the hole are sharp to minimise frictional losses by minimising the contact between the hole and the liquid.

The streamlines at the orifice contract reducing the area of flow.

This contraction is called the *vena contracta*

The amount of contraction must be known to calculate the flow

Apply Bernoulli along the streamline joining point 1 on the surface to point 2 at the centre of the orifice.

At the surface velocity is negligible ( $u_1 = 0$ ) and the pressure atmospheric ( $p_1 = 0$ ).

At the orifice the jet is open to the air so again the pressure is atmospheric ( $p_2 = 0$ ).

If we take the datum line through the orifice then  $z_1 = h$  and  $z_2 = 0$ , leaving

$$h = \frac{u_2^2}{2g}$$

$$u_2 = \sqrt{2gh}$$

This theoretical value of velocity is an overestimate as friction losses have not been taken into account.

A coefficient of velocity is used to correct the theoretical velocity,

$$u_{actual} = C_v u_{theoretical}$$

Each orifice has its own *coefficient of velocity*, they usually lie in the range( 0.97 - 0.99)

**The discharge through the orifice**

is  
jet area  $\times$  jet velocity

The area of the jet is the area of the vena contracta not  
the area of the orifice.

We use a coefficient of contraction  
to get the area of the jet

$$A_{actual} = C_c A_{orifice}$$

Giving discharge through the orifice:

$$Q = Au$$

$$\begin{aligned} Q_{actual} &= A_{actual} u_{actual} \\ &= C_c C_v A_{orifice} u_{theoretical} \\ &= C_d A_{orifice} u_{theoretical} \\ &= C_d A_{orifice} \sqrt{2gh} \end{aligned}$$

$C_d$  is the coefficient of discharge,

$$C_d = C_c \times C_v$$

**Time for the tank to empty**

We have an expression for the discharge from the tank

$$Q = C_d A_o \sqrt{2gh}$$

We can use this to calculate how long  
it will take for level in the tank to fall

As the tank empties the level of water falls.

The discharge will also drop.

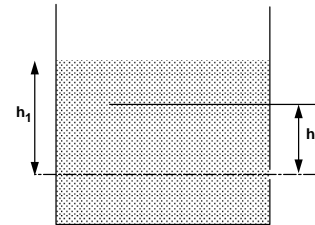

The tank has a cross sectional area of  $A$ .

In a time  $\delta t$  the level falls by  $\delta h$

The flow out of the tank is

$$Q = Au$$

$$Q = -A \frac{\delta h}{\delta t}$$

(-ve sign as  $\delta h$  is falling)

This  $Q$  is the same as the flow out of the orifice so

$$C_d A_o \sqrt{2gh} = -A \frac{\delta h}{\delta t}$$

$$\delta t = \frac{-A}{C_d A_o \sqrt{2g}} \frac{\delta h}{\sqrt{h}}$$

Integrating between the initial level,  $h_1$ , and final level,  $h_2$ ,  
gives the time it takes to fall this height

$$t = \frac{-A}{C_d A_o \sqrt{2g}} \int_{h_1}^{h_2} \frac{\delta h}{\sqrt{h}}$$

$$\left( \int \frac{1}{\sqrt{h}} = \int h^{-1/2} = 2h^{1/2} = 2\sqrt{h} \right)$$

$$\begin{aligned} t &= \frac{-A}{C_d A_o \sqrt{2g}} [2\sqrt{h}]_{h_1}^{h_2} \\ &= \frac{-2A}{C_d A_o \sqrt{2g}} [\sqrt{h_2} - \sqrt{h_1}] \end{aligned}$$

**Submerged Orifice**

What if the tank is feeding into another?

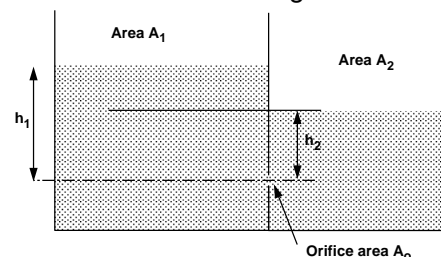

Apply Bernoulli from point 1 on the surface of the deeper  
tank to point 2 at the centre of the orifice,

$$\frac{p_1}{\rho g} + \frac{u_1^2}{2g} + z_1 = \frac{p_2}{\rho g} + \frac{u_2^2}{2g} + z_2$$

$$0 + 0 + h_1 = \frac{\rho g h_2}{\rho g} + \frac{u_2^2}{2g} + 0$$

$$u_2 = \sqrt{2g(h_1 - h_2)}$$

And the discharge is given by

$$\begin{aligned} Q &= C_d A_o u \\ &= C_d A_o \sqrt{2g(h_1 - h_2)} \end{aligned}$$

So the discharge of the jet through the submerged orifice  
depends on the *difference* in head across the orifice.

## Lecture 10: Flow Measurement Devices

### Unit 3: Fluid Dynamics

#### Pitot Tube

The Pitot tube is a simple velocity measuring device.

Uniform velocity flow hitting a solid blunt body, has streamlines similar to this:

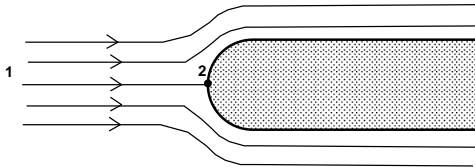

Some move to the left and some to the right. The centre one hits the blunt body and stops.

At this point (2) velocity is zero

The fluid does not move at this one point. This point is known as the *stagnation point*.

Using the Bernoulli equation we can calculate the pressure at this point.

Along the central streamline at 1: velocity  $u_1$ , pressure  $p_1$   
At the stagnation point (2):  $u_2 = 0$ . (Also  $z_1 = z_2$ )

$$\frac{p_1}{\rho} + \frac{u_1^2}{2} = \frac{p_2}{\rho}$$

$$p_2 = p_1 + \frac{1}{2} \rho u_1^2$$

#### How can we use this?

The blunt body does not have to be a solid. It could be a static column of fluid.

Two piezometers, one as normal and one as a Pitot tube within the pipe can be used as shown below to measure velocity of flow.

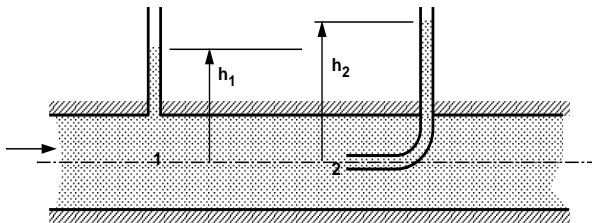

We have the equation for  $p_2$ ,

$$p_2 = p_1 + \frac{1}{2} \rho u_1^2$$

$$\rho g h_2 = \rho g h_1 + \frac{1}{2} \rho u_1^2$$

$$u = \sqrt{2g(h_2 - h_1)}$$

We now have an expression for velocity from two pressure measurements and the application of the Bernoulli equation.

#### Pitot Static Tube

The necessity of two piezometers makes this arrangement awkward.

The *Pitot static* tube combines the tubes and they can then be easily connected to a manometer.

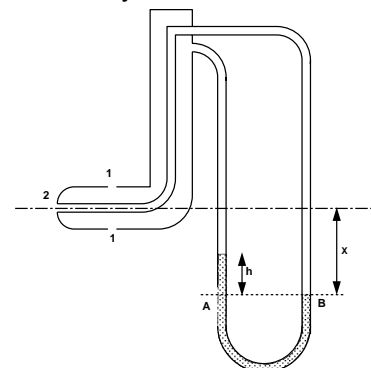

[Note: the diagram of the Pitot tube is not to scale. In reality its diameter is very small and can be ignored i.e. points 1 and 2 are considered to be at the same level]

The holes on the side connect to one side of a manometer, while the central hole connects to the other side of the manometer

Using the theory of the manometer,

$$p_A = p_1 + \rho g(X - h) + \rho_{man}gh$$

$$p_B = p_2 + \rho gX$$

$$p_A = p_B$$

$$p_2 + \rho gX = p_1 + \rho g(X - h) + \rho_{man}gh$$

We know that  $p_2 = p_1 + \frac{1}{2}\rho u_1^2$ , giving

$$p_1 + hg(\rho_{man} - \rho) = p_1 + \frac{\rho u_1^2}{2}$$

$$u_1 = \sqrt{\frac{2gh(\rho_m - \rho)}{\rho}}$$

The Pitot/Pitot-static is:

- Simple to use (and analyse)
- Gives velocities (not discharge)
- May block easily as the holes are small.

### Pitot-Static Tube Example

A pitot-static tube is used to measure the air flow at the centre of a 400mm diameter building ventilation duct.

If the height measured on the attached manometer is 10 mm and the density of the manometer fluid is 1000 kg/m<sup>3</sup>, determine the volume flow rate in the duct. Assume that the density of air is 1.2 kg/m<sup>3</sup>.

### Venturi Meter

The Venturi meter is a device for measuring **discharge** in a pipe.

It is a rapidly converging section which **increases** the velocity of flow and hence **reduces** the pressure.

It then returns to the original dimensions of the pipe by a gently diverging 'diffuser' section.

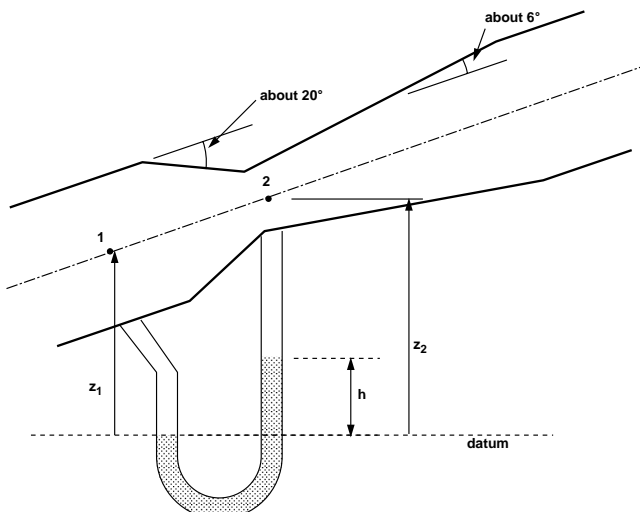

Apply Bernoulli along the streamline from point 1 to point 2

$$\frac{p_1}{\rho g} + \frac{u_1^2}{2g} + z_1 = \frac{p_2}{\rho g} + \frac{u_2^2}{2g} + z_2$$

By continuity

$$Q = u_1 A_1 = u_2 A_2$$

$$u_2 = \frac{u_1 A_1}{A_2}$$

Substituting and rearranging gives

$$\begin{aligned} \frac{p_1 - p_2}{\rho g} + z_1 - z_2 &= \frac{u_1^2}{2g} \left[ \left( \frac{A_1}{A_2} \right)^2 - 1 \right] \\ &= \frac{u_1^2}{2g} \left[ \frac{A_1^2 - A_2^2}{A_2^2} \right] \end{aligned}$$

$$u_1 = A_2 \sqrt{\frac{2g \left[ \frac{p_1 - p_2}{\rho g} + z_1 - z_2 \right]}{A_1^2 - A_2^2}}$$

The theoretical (ideal) discharge is  $u \times A$ .

Actual discharge takes into account the losses due to friction, we include a coefficient of discharge ( $C_d \approx 0.9$ )

$$Q_{ideal} = u_1 A_1$$

$$Q_{actual} = C_d Q_{ideal} = C_d u_1 A_1$$

$$Q_{actual} = C_d A_1 A_2 \sqrt{\frac{2g \left[ \frac{p_1 - p_2}{\rho g} + z_1 - z_2 \right]}{A_1^2 - A_2^2}}$$

In terms of the manometer readings

$$p_1 + \rho g z_1 = p_2 + \rho_{man} g h + \rho g (z_2 - h)$$

$$\frac{p_1 - p_2}{\rho g} + z_1 - z_2 = h \left( \frac{\rho_{man}}{\rho} - 1 \right)$$

Giving

$$Q_{actual} = C_d A_1 A_2 \sqrt{\frac{2gh \left( \frac{\rho_{man}}{\rho} - 1 \right)}{A_1^2 - A_2^2}}$$

This expression does not include any elevation terms. ( $z_1$  or  $z_2$ )

When used with a manometer

The Venturimeter can be used without knowing its angle.

### Venturimeter design:

- The diffuser assures a gradual and steady deceleration after the throat. So that pressure rises to something near that before the meter.
- The angle of the diffuser is usually between 6 and 8 degrees.
- Wider and the flow might separate from the walls increasing energy loss.
- If the angle is less the meter becomes very long and pressure losses again become significant.
- The efficiency of the diffuser of increasing pressure back to the original is rarely greater than 80%.
- Care must be taken when connecting the manometer so that no burrs are present.

### Venturimeter Example

**A venturimeter is used to measure the flow of water in a 150 mm diameter pipe. The throat diameter of the venturimeter is 60 mm and the discharge coefficient is 0.9. If the pressure difference measured by a manometer is 10 cm mercury, what is the average velocity in the pipe?**

**Assume water has a density of 1000 kg/m<sup>3</sup> and mercury has a relative density of 13.6.**

## Lecture 11: Notches and Weirs

### Unit 3: Fluid Dynamics

- A notch is an opening in the side of a tank or reservoir.
  - It is a device for measuring discharge
- A weir is a notch on a larger scale - usually found in rivers.
- It is used as both a discharge measuring device and a device to raise water levels.
  - There are many different designs of weir.
    - We will look at sharp crested weirs.

#### Weir Assumptions

- velocity of the fluid approaching the weir is small so we can ignore kinetic energy.
- The velocity in the flow depends only on the depth below the free surface.  $u = \sqrt{2gh}$

These assumptions are fine for tanks with notches or reservoirs with weirs, in rivers with high velocity approaching the weir is substantial the kinetic energy must be taken into account

## A General Weir Equation

Consider a horizontal strip of width  $b$ , depth  $h$  below the free surface

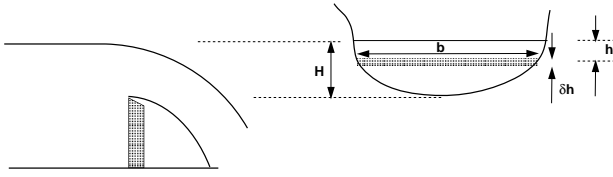

velocity through the strip,  $u = \sqrt{2gh}$

discharge through the strip,  $\delta Q = Au = b\delta h\sqrt{2gh}$

Integrating from the free surface,  $h=0$ , to the weir crest,  $h=H$ , gives the total theoretical discharge

$$Q_{\text{theoretical}} = \sqrt{2g} \int_0^H bh^{1/2} dh$$

This is different for every differently shaped weir or notch.

We need an expression relating the width of flow across the weir to the depth below the free surface.

## Rectangular Weir

The width does not change with depth so

$$b = \text{constant} = B$$

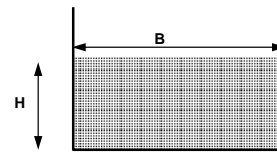

Substituting this into the general weir equation gives

$$\begin{aligned} Q_{\text{theoretical}} &= B\sqrt{2g} \int_0^H h^{1/2} dh \\ &= \frac{2}{3} B\sqrt{2g} H^{3/2} \end{aligned}$$

To get the actual discharge we introduce a coefficient of discharge,  $C_d$ , to account for losses at the edges of the weir and contractions in the area of flow,

$$Q_{\text{actual}} = C_d \frac{2}{3} B\sqrt{2g} H^{3/2}$$

## Rectangular Weir Example

Water enters the Millwood flood storage area via a rectangular weir when the river height exceeds the weir crest. For design purposes a flow rate of 162 litres/s over the weir can be assumed

1. Assuming a height over the crest of 20cm and  $C_d=0.2$ , what is the necessary width,  $B$ , of the weir?

2. What will be the velocity over the weir at this design?

## 'V' Notch Weir

The relationship between width and depth is dependent on the angle of the "V".

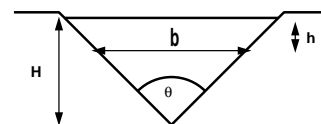

The width,  $b$ , at a depth  $h$  from the free surface is

$$b = 2(H - h)\tan\left(\frac{\theta}{2}\right)$$

So the discharge is

$$\begin{aligned} Q_{\text{theoretical}} &= 2\sqrt{2g} \tan\left(\frac{\theta}{2}\right) \int_0^H (H - h)h^{1/2} dh \\ &= 2\sqrt{2g} \tan\left(\frac{\theta}{2}\right) \left[ \frac{2}{3} Hh^{3/2} - \frac{2}{5} h^{5/2} \right]_0^H \\ &= \frac{8}{15} \sqrt{2g} \tan\left(\frac{\theta}{2}\right) H^{5/2} \end{aligned}$$

The actual discharge is obtained by introducing a coefficient of discharge

$$Q_{\text{actual}} = C_d \frac{8}{15} \sqrt{2g} \tan\left(\frac{\theta}{2}\right) H^{5/2}$$

**'V' Notch Weir Example**

Water is flowing over a  $90^\circ$  'V' Notch weir into a tank with a cross-sectional area of  $0.6\text{m}^2$ . After 30s the depth of the water in the tank is 1.5m.

If the discharge coefficient for the weir is 0.8, what is the height of the water above the weir?

## **Lecture 12: The Momentum Equation**

### **Unit 3: Fluid Dynamics**

We have all seen moving fluids exerting forces.

- The lift force on an aircraft is exerted by the air moving over the wing.
- A jet of water from a hose exerts a force on whatever it hits.

The analysis of motion is as in solid mechanics: by use of Newton's laws of motion.

The **Momentum equation** is a statement of Newton's Second Law

It relates the sum of the forces to the acceleration or rate of change of momentum.

From solid mechanics you will recognise  
 $F = ma$

What mass of moving fluid we should use?

We use a different form of the equation.

Consider a streamtube:

And assume steady non-uniform flow

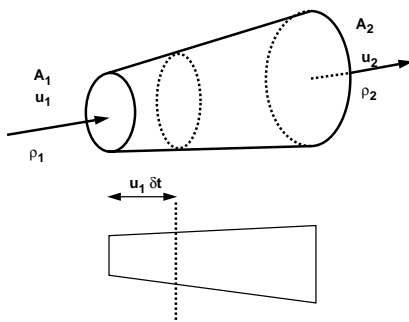

In time  $\delta t$  a volume of the fluid moves from the inlet a distance  $u_1 \delta t$ , so

$$\begin{aligned} \text{volume entering the stream tube} &= \text{area} \times \text{distance} \\ &= A_1 u_1 \delta t \end{aligned}$$

The mass entering,

$$\begin{aligned} \text{mass entering stream tube} &= \text{volume} \times \text{density} \\ &= \rho_1 A_1 u_1 \delta t \end{aligned}$$

And momentum

$$\begin{aligned} \text{momentum entering stream tube} &= \text{mass} \times \text{velocity} \\ &= \rho_1 A_1 u_1 \delta t u_1 \end{aligned}$$

Similarly, at the exit, we get the expression:

$$\text{momentum leaving stream tube} = \rho_2 A_2 u_2 \delta t u_2$$

**By Newton's 2<sup>nd</sup> Law.**

Force = rate of change of momentum

$$F = \frac{(\rho_2 A_2 u_2 \delta t - \rho_1 A_1 u_1 \delta t)}{\delta t}$$

We know from continuity that

$$Q = A_1 u_1 = A_2 u_2$$

And if we have a fluid of constant density,  
i.e.  $\rho_1 = \rho_2 = \rho$ , then

$$F = Q\rho(u_2 - u_1)$$

**An alternative derivation**

From conservation of mass

mass into face 1 = mass out of face 2

we can write

$$\begin{aligned} \text{rate of change of mass} &= \dot{m} = \frac{dm}{dt} \\ &= \rho_1 A_1 u_1 = \rho_2 A_2 u_2 \end{aligned}$$

The rate at which momentum enters face 1 is

$$\rho_1 A_1 u_1 u_1 = \dot{m} u_1$$

The rate at which momentum leaves face 2 is

$$\rho_2 A_2 u_2 u_2 = \dot{m} u_2$$

Thus the rate at which momentum changes across  
the stream tube is

$$\rho_2 A_2 u_2 u_2 - \rho_1 A_1 u_1 u_1 = \dot{m} u_2 - \dot{m} u_1$$

So

Force = rate of change of momentum

$$F = \dot{m}(u_2 - u_1)$$

So we have these two expressions,  
either one is known as the momentum equation

$$F = \dot{m}(u_2 - u_1)$$

$$F = Q\rho(u_2 - u_1)$$

The Momentum equation.

This force acts on the fluid  
in the direction of the flow of the fluid.

The previous analysis assumed the inlet and outlet  
velocities in the same direction  
i.e. a one dimensional system.

What happens when this is not the case?

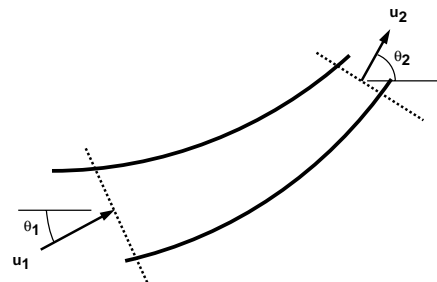

We consider the forces by resolving in the  
directions of the co-ordinate axes.

The force in the x-direction

$$F_x = \dot{m}(u_2 \cos \theta_2 - u_1 \cos \theta_1)$$

$$= \dot{m}(u_{2x} - u_{1x})$$

or

$$F_x = \rho Q(u_2 \cos \theta_2 - u_1 \cos \theta_1)$$

$$= \rho Q(u_{2x} - u_{1x})$$

And the force in the y-direction

$$F_y = \dot{m}(u_2 \sin \theta_2 - u_1 \sin \theta_1)$$

$$= \dot{m}(u_{2,y} - u_{1,y})$$

or

$$F_y = \rho Q(u_2 \sin \theta_2 - u_1 \sin \theta_1)$$

$$= \rho Q(u_{2,y} - u_{1,y})$$

The resultant force can be found by combining these components

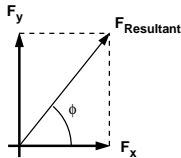

$$F_{\text{resultant}} = \sqrt{F_x^2 + F_y^2}$$

And the angle of this force

$$\phi = \tan^{-1}\left(\frac{F_y}{F_x}\right)$$

In summary we can say:

Total force on the fluid = rate of change of momentum through the control volume

$$F = \dot{m}(u_{\text{out}} - u_{\text{in}})$$

or

$$F = \rho Q(u_{\text{out}} - u_{\text{in}})$$

Remember that we are working with vectors so F is in the direction of the velocity.

This force is made up of three components:

$F_R$  = Force exerted on the fluid by any solid body touching the control volume

$F_B$  = Force exerted on the fluid body (e.g. gravity)

$F_P$  = Force exerted on the fluid by fluid pressure outside the control volume

So we say that the total force,  $F_T$ , is given by the sum of these forces:

$$F_T = F_R + F_B + F_P$$

The force exerted  
by the fluid  
on the solid body

touching the control volume is opposite to  $F_R$ .

So the reaction force,  $R$ , is given by

$$R = -F_R$$

## Application of the Momentum Equation

### **Forces on a Bend**

Consider a converging or diverging pipe bend lying in the vertical or horizontal plane turning through an angle of  $\theta$ .

Here is a diagram of a diverging pipe bend.

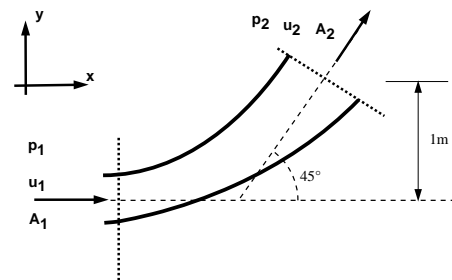

Why do we want to know the forces here?

As the fluid changes direction  
a force will act on the bend.

This force can be very large in the case of water supply pipes. The bend must be held in place to prevent breakage at the joints.

We need to know how much force a support (thrust block) must withstand.

Step in Analysis:

1. Draw a control volume
2. Decide on co-ordinate axis system
3. Calculate the total force
4. Calculate the pressure force
5. Calculate the body force
6. Calculate the resultant force

An Example of Forces on a Bend

The outlet pipe from a pump is a bend of  $45^\circ$  rising in the vertical plane (i.e. and internal angle of  $135^\circ$ ). The bend is 150mm diameter at its inlet and 300mm diameter at its outlet. The pipe axis at the inlet is horizontal and at the outlet it is 1m higher. By neglecting friction, calculate the force and its direction if the inlet pressure is  $100\text{kN/m}^2$  and the flow of water through the pipe is  $0.3\text{m}^3/\text{s}$ . The volume of the pipe is  $0.075\text{m}^3$ . [ $13.95\text{kN}$  at  $67^\circ 39'$  to the horizontal]

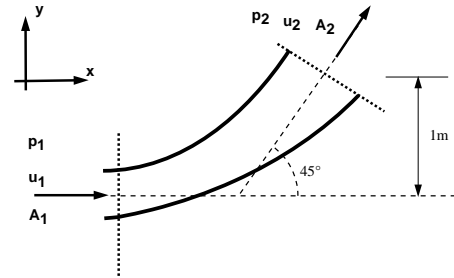
1&2 Draw the control volume and the axis system

$$p_1 = 100 \text{ kN/m}^2,$$

$$Q = 0.3 \text{ m}^3/\text{s}$$

$$\theta = 45^\circ$$

$$d_1 = 0.15 \text{ m}$$

$$d_2 = 0.3 \text{ m}$$

$$A_1 = 0.177 \text{ m}^2$$

$$A_2 = 0.0707 \text{ m}^2$$

3 Calculate the total force  
in the x direction

$$F_{T_x} = \rho Q(u_{2x} - u_{1x})$$

$$= \rho Q(u_2 \cos \theta - u_1)$$

by continuity  $A_1 u_1 = A_2 u_2 = Q$ , so

$$u_1 = \frac{0.3}{\pi(0.15^2/4)} = 16.98 \text{ m/s}$$

$$u_2 = \frac{0.3}{0.0707} = 4.24 \text{ m/s}$$

$$F_{T_x} = 1000 \times 0.3(4.24 \cos 45 - 16.98)$$

$$= -4193.68 \text{ N}$$

and in the y-direction

$$F_{T_y} = \rho Q(u_{2y} - u_{1y})$$

$$= \rho Q(u_2 \sin \theta - 0)$$

$$= 1000 \times 0.3(4.24 \sin 45)$$

$$= 899.44 \text{ N}$$

4 Calculate the pressure force.

$F_p$  = pressure force at 1 - pressure force at 2

$$\theta_1 = 0, \quad \theta_2 = \theta$$

$$F_{p_x} = p_1 A_1 \cos 0 - p_2 A_2 \cos \theta = p_1 A_1 - p_2 A_2 \cos \theta$$

$$F_{p_y} = p_1 A_1 \sin 0 - p_2 A_2 \sin \theta = -p_2 A_2 \sin \theta$$

We know pressure at the inlet  
but not at the outlet

we can use the Bernoulli equation  
to calculate this unknown pressure.

$$\frac{p_1}{\rho g} + \frac{u_1^2}{2g} + z_1 = \frac{p_2}{\rho g} + \frac{u_2^2}{2g} + z_2 + h_f$$

where  $h_f$  is the friction loss

In the question it says this can be ignored,  $h_f = 0$

The height of the pipe at the outlet  
is 1m above the inlet.

Taking the inlet level as the datum:

$$z_1 = 0 \quad z_2 = 1\text{m}$$

So the Bernoulli equation becomes:

$$\frac{100000}{1000 \times 9.81} + \frac{16.98^2}{2 \times 9.81} + 0 = \frac{p_2}{1000 \times 9.81} + \frac{4.24^2}{2 \times 9.81} + 1.0$$

$$p_2 = 225361.4 \text{ N/m}^2$$

$$F_{P_x} = 100000 \times 0.0177 - 225361.4 \cos 45 \times 0.0707$$

$$= 1770 - 11266.34 = -9496.37 \text{ kN}$$

$$F_{P_y} = -225361.4 \sin 45 \times 0.0707$$

$$= -11266.37$$

### 5 Calculate the body force

The only body force is the force due to gravity. That is the weight acting in the -ve y direction.

$$F_{B_y} = -\rho g \times \text{volume}$$

$$= -1000 \times 9.81 \times 0.075$$

$$= -12901.56 \text{ N}$$

There are no body forces in the x direction,

$$F_{B_x} = 0$$

### 6 Calculate the resultant force

$$F_{T_x} = F_{R_x} + F_{P_x} + F_{B_x}$$

$$F_{T_y} = F_{R_y} + F_{P_y} + F_{B_y}$$

$$F_{R_x} = F_{T_x} - F_{P_x} - F_{B_x}$$

$$= -4193.6 + 9496.37$$

$$= 5302.7 \text{ N}$$

$$F_{R_y} = F_{T_y} - F_{P_y} - F_{B_y}$$

$$= 899.44 + 11266.37 + 735.75$$

$$= 12901.56 \text{ N}$$

And the resultant force on the fluid is given by

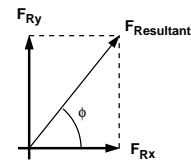

$$F_R = \sqrt{F_{R_x}^2 + F_{R_y}^2}$$

$$= \sqrt{5302.7^2 + 12901.56^2}$$

$$= 13.95 \text{ kN}$$

And the direction of application is

$$\phi = \tan^{-1} \left( \frac{F_{R_y}}{F_{R_x}} \right)$$

$$= \tan^{-1} \left( \frac{12901.56}{5302.7} \right)$$

$$= 67.66^\circ = 67^\circ 39'$$

The force on the bend is the same magnitude but in the opposite direction

$$R = -F_R = -13.95 \text{ kN}$$

### Lecture 13: Design Study 2

See Separate Handout

### Lecture 14: Momentum Equation Examples Unit 3: Fluid Dynamics

#### Impact of a Jet on a Plane

A jet hitting a flat plate (a plane) at an angle of  $90^\circ$

We want to find the reaction force of the plate.  
i.e. the force the plate will have to apply to stay in the same position.

1 & 2 Control volume and Co-ordinate axis are shown in the figure below.

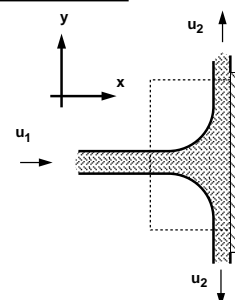

**3 Calculate the total force**

In the x-direction

$$F_{T_x} = \rho Q(u_{2x} - u_{1x})$$

$$= -\rho Q u_{1x}$$

The system is symmetrical  
the forces in the y-direction cancel.

$$F_{T_y} = 0$$

**4 Calculate the pressure force.**

The pressures at both the inlet and the outlets  
to the control volume are atmospheric.

The pressure force is zero

$$F_{P_x} = F_{P_y} = 0$$

**5 Calculate the body force**

As the control volume is small  
we can ignore the body force due to gravity.

$$F_{B_x} = F_{B_y} = 0$$

**6 Calculate the resultant force**

$$F_{T_x} = F_{R_x} + F_{P_x} + F_{B_x}$$

$$F_{R_x} = F_{T_x} - 0 - 0$$

$$= -\rho Q u_{1x}$$

Exerted on the fluid.

The force on the plane is the same magnitude but in  
the opposite direction

$$R = -F_{R_x}$$

If the plane were at an angle  
the analysis is the same.

But it is usually most convenient to choose the axis  
system normal to the plate.

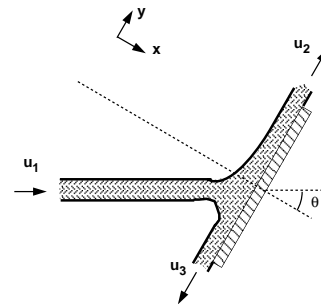
**Force on a curved vane**

This case is similar to that of a pipe, but the  
analysis is simpler.

Pressures at ends are equal at atmospheric

Both the cross-section and velocities  
(in the direction of flow) remain constant.

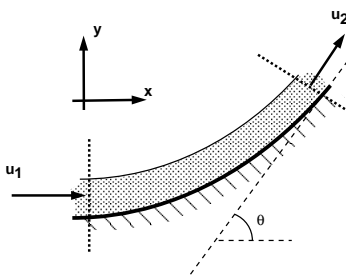

1 & 2 Control volume and Co-ordinate axis are  
shown in the figure above.

**3 Calculate the total force  
in the x direction**

$$F_{T_x} = \rho Q(u_2 - u_1 \cos \theta)$$

by continuity  $u_1 = u_2 = \frac{Q}{A}$ , so

$$F_{T_x} = -\rho \frac{Q^2}{A} (1 - \cos \theta)$$

and in the y-direction

$$F_{T_y} = \rho Q(u_2 \sin \theta - 0)$$

$$= \rho \frac{Q^2}{A}$$

**4 Calculate the pressure force.**

The pressure at both the inlet and the outlets to the  
control volume is atmospheric.

$$F_{P_x} = F_{P_y} = 0$$

### 5 Calculate the body force

No body forces in the x-direction,  $F_{B_x} = 0$ .

In the y-direction the body force acting is the weight of the fluid.

If  $V$  is the volume of the fluid on the vane then,

$$F_{B_x} = \rho g V$$

(This is often small as the jet volume is small and sometimes ignored in analysis.)

### 6 Calculate the resultant force

$$F_{T_x} = F_{R_x} + F_{P_x} + F_{B_x}$$

$$F_{R_x} = F_{T_x} = -\rho \frac{Q^2}{A} (1 - \cos \theta)$$

$$F_{T_y} = F_{R_y} + F_{P_y} + F_{B_y}$$

$$F_{R_y} = F_{T_y} = \rho \frac{Q^2}{A}$$

And the resultant force on the fluid is given by

$$F_R = \sqrt{F_{R_x}^2 + F_{R_y}^2}$$

And the direction of application is

$$\phi = \tan^{-1} \left( \frac{F_{R_y}}{F_{R_x}} \right)$$

exerted on the fluid.

The force on the vane is the same magnitude but in the opposite direction

$$R = -F_R$$

## SUMMARY

The Momentum equation is a statement of Newton's Second Law

For a fluid of constant density,

Total force on the fluid = rate of change of momentum through the control volume

$$F = \dot{m}(u_{\text{out}} - u_{\text{in}}) = \rho Q(u_{\text{out}} - u_{\text{in}})$$

This force acts on the fluid in the direction of the velocity of fluid.

This is the total force  $F_T$  where:

$$F_T = F_R + F_B + F_P$$

$F_R$  = External force on the fluid from any solid body touching the control volume

$F_B$  = Body force on the fluid body (e.g. gravity)

$F_P$  = Pressure force on the fluid by fluid pressure outside the control volume

We work with components of the force:

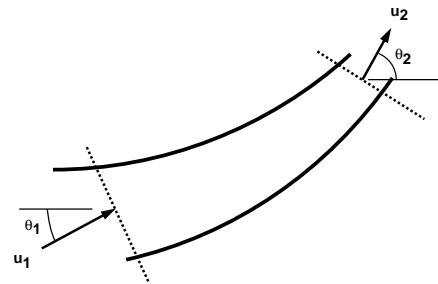

$$F_x = \rho Q(u_{2_x} - u_{1_x}) = \rho Q(u_2 \cos \theta_2 - u_1 \cos \theta_1)$$

$$F_y = \rho Q(u_{2_y} - u_{1_y}) = \rho Q(u_2 \sin \theta_2 - u_1 \sin \theta_1)$$

The resultant force can be found by combining these components

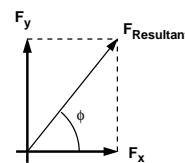

$$F_{\text{resultant}} = \sqrt{F_x^2 + F_y^2}$$

And the angle this force acts:

$$\phi = \tan^{-1} \left( \frac{F_y}{F_x} \right)$$

## Lecture 15: Calculations

### Unit 3: Fluid Dynamics

1. The figure below shows a smooth curved vane attached to a rigid foundation. The jet of water, rectangular in section, 75mm wide and 25mm thick, strike the vane with a velocity of 25m/s. Calculate the vertical and horizontal components of the force exerted on the vane and indicate in which direction these components act.

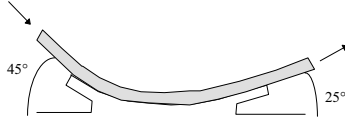

2. A 600mm diameter pipeline carries water under a head of 30m with a velocity of 3m/s. This water main is fitted with a horizontal bend which turns the axis of the pipeline through  $75^\circ$  (i.e. the internal angle at the bend is  $105^\circ$ ). Calculate the resultant force on the bend and its angle to the horizontal.

3. A 75mm diameter jet of water having a velocity of 25m/s strikes a flat plate, the normal of which is inclined at  $30^\circ$  to the jet. Find the force normal to the surface of the plate.

4. In an experiment a jet of water of diameter 20mm is fired vertically upwards at a sprung target that deflects the water at an angle of  $120^\circ$  to the horizontal in all directions. If a 500g mass placed on the target balances the force of the jet, what is the discharge of the jet in litres/s?

5. Water is being fired at 10 m/s from a hose of 50mm diameter into the atmosphere. The water leaves the hose through a nozzle with a diameter of 30mm at its exit. Find the pressure just upstream of the nozzle and the force on the nozzle.

**CIVE1400: An Introduction to Fluid Mechanics****Dr P A Sleigh**

P.A.Sleigh@leeds.ac.uk

**Dr CJ Noakes**

C.J.Noakes@leeds.ac.uk

January 2008

Module web site:

www.efm.leeds.ac.uk/CIVE/FluidsLevel1

Unit 1: Fluid Mechanics Basics 3 lectures

Flow  
Pressure  
Properties of Fluids  
Fluids vs. Solids  
Viscosity

Unit 2: Statics 3 lectures

Hydrostatic pressure  
Manometry/Pressure measurement  
Hydrostatic forces on submerged surfaces

Unit 3: Dynamics 7 lectures

The continuity equation.  
The Bernoulli Equation.  
Application of Bernoulli equation.  
The momentum equation.  
Application of momentum equation.

Unit 4: Effect of the boundary on flow 4 lectures

Laminar and turbulent flow  
Boundary layer theory  
An Intro to Dimensional analysis  
Similarity**Real fluids****Flowing real fluids exhibit viscous effects, they:**

- “stick” to solid surfaces
- have stresses within their body.

**From earlier we saw this relationship between shear stress and velocity gradient:**

$$\tau \propto \frac{du}{dy}$$

**The shear stress,  $\tau$ , in a fluid is proportional to the velocity gradient - the rate of change of velocity across the flow.****For a “Newtonian” fluid we can write:**

$$\tau = \mu \frac{du}{dy}$$

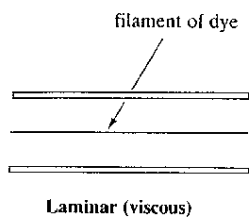
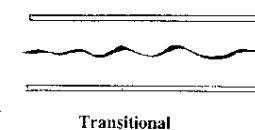
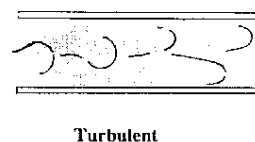
**where  $\mu$ , is coefficient of viscosity (or simply viscosity).****Here we look at the influence of forces due to momentum changes and viscosity in a moving fluid.****Laminar and turbulent flow****Injecting a dye into the middle of flow in a pipe, what would we expect to happen?****This****this****or this****All three would happen - but for different flow rates.**

**Top: Slow flow**  
**Middle: Medium flow**  
**Bottom: Fast flow**

**Top: Laminar flow**  
**Middle: Transitional flow**  
**Bottom: Turbulent flow**

**Laminar flow:****Motion of the fluid particles is very orderly all particles moving in straight lines parallel to the pipe walls.****Turbulent flow:****Motion is, locally, completely random but the overall direction of flow is one way.****But what is fast or slow?****At what speed does the flow pattern change?****And why might we want to know this?**

The was first investigated in the 1880s  
by Osbourne Reynolds  
in a classic experiment in fluid mechanics.

A tank arranged as below:

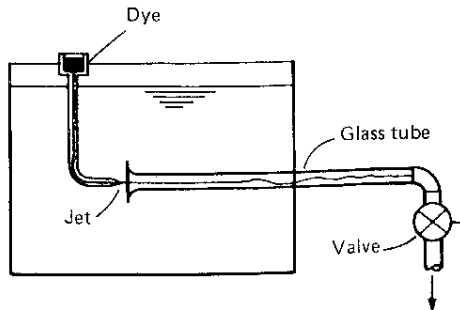

After many experiments he found this  
expression

$$\frac{\rho u d}{\mu}$$

$\rho$  = density,       $u$  = mean velocity,  
 $d$  = diameter       $\mu$  = viscosity

This could be used to predict the change in  
flow type for any fluid.

This value is known as the  
Reynolds number, Re:

$$Re = \frac{\rho u d}{\mu}$$

Laminar flow:                       $Re < 2000$   
Transitional flow:       $2000 < Re < 4000$   
Turbulent flow:                       $Re > 4000$

### What are the units of Reynolds number?

We can fill in the equation with SI units:

$$\rho = \text{kg} / \text{m}^3, \quad u = \text{m} / \text{s}, \quad d = \text{m}$$

$$\mu = \text{Ns} / \text{m}^2 = \text{kg} / \text{m s}$$

$$Re = \frac{\rho u d}{\mu} = \frac{\text{kg m m ms}}{\text{m}^3 \text{ s } 1 \text{ kg}} = 1$$

**It has no units!**

A quantity with no units is known as a  
non-dimensional (or dimensionless) quantity.

(We will see more of these in the section on  
dimensional analysis.)

**The Reynolds number, Re,  
is a non-dimensional number.**

### At what speed does the flow pattern change?

We use the Reynolds number in an example:

**A pipe and the fluid flowing  
have the following properties:**

water density                       $\rho = 1000 \text{ kg/m}^3$   
pipe diameter                       $d = 0.5 \text{ m}$   
(dynamic) viscosity,               $\mu = 0.55 \times 10^{-3} \text{ Ns/m}^2$

**What is the MAXIMUM velocity when flow is  
laminar i.e.  $Re = 2000$**

$$Re = \frac{\rho u d}{\mu} = 2000$$

$$u = \frac{2000 \mu}{\rho d} = \frac{2000 \times 0.55 \times 10^{-3}}{1000 \times 0.5}$$

$$u = 0.0022 \text{ m/s}$$

What is the **MINIMUM** velocity when flow is turbulent i.e.  $Re = 4000$

$$Re = \frac{\rho u d}{\mu} = 4000$$

$$u = 0.0044 \text{ m/s}$$

In a house central heating system, typical pipe diameter = 0.015m,

limiting velocities would be, 0.0733 and 0.147m/s.

Both of these are very slow.

In practice laminar flow rarely occurs in a piped water system.

Laminar flow does occur in fluids of greater viscosity e.g. in bearing with oil as the lubricant.

What does this abstract number mean?

We can give the Re number a physical meaning.

This may help to understand some of the reasons for the changes from laminar to turbulent flow.

$$Re = \frac{\rho u d}{\mu}$$

$$= \frac{\text{inertial forces}}{\text{viscous forces}}$$

When inertial forces dominate (when the fluid is flowing faster and Re is larger) the flow is turbulent.

When the viscous forces are dominant (slow flow, low Re) they keep the fluid particles in line, the flow is laminar.

### Laminar flow

- $Re < 2000$
- 'low' velocity
- Dye does not mix with water
- Fluid particles move in straight lines
- Simple mathematical analysis possible
- Rare in practice in water systems.

### Transitional flow

- $2000 > Re < 4000$
- 'medium' velocity
- Dye stream wavers - mixes slightly.

### Turbulent flow

- $Re > 4000$
- 'high' velocity
- Dye mixes rapidly and completely
- Particle paths completely irregular
- Average motion is in flow direction
- Cannot be seen by the naked eye
- Changes/fluctuations are very difficult to detect. Must use laser.
- Mathematical analysis very difficult - so experimental measures are used
- Most common type of flow.

### Pressure loss due to friction in a pipeline

Up to now we have considered ideal fluids:  
no energy losses due to friction

Because fluids are viscous,  
energy is lost by flowing fluids due to friction.

This must be taken into account.

The effect of the friction shows itself as a  
pressure (or head) loss.

In a real flowing fluid shear stress  
slows the flow.

To give a velocity profile:

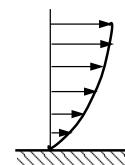

Attaching a manometer gives pressure (head) loss due to the energy lost by the fluid overcoming the shear stress.

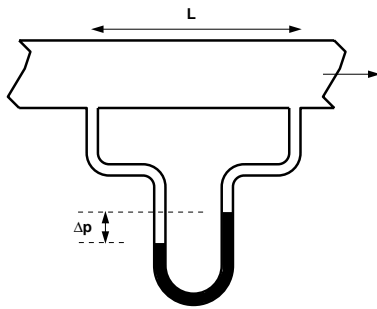

The pressure at 1 (upstream) is higher than the pressure at 2.

How can we quantify this pressure loss in terms of the forces acting on the fluid?

Consider a cylindrical element of incompressible fluid flowing in the pipe,

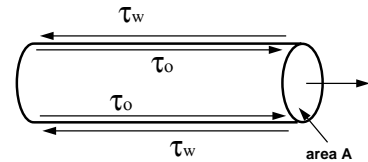

$\tau_w$  is the mean shear stress on the boundary  
Upstream pressure is  $p$ ,  
Downstream pressure falls by  $\Delta p$  to  $(p - \Delta p)$

The driving force due to pressure

driving force = Pressure force at 1 - pressure force at 2

$$pA - (p - \Delta p)A = \Delta p A = \Delta p \frac{\pi d^2}{4}$$

The retarding force is due to the shear stress

$$\begin{aligned} &= \text{shear stress} \times \text{area over which it acts} \\ &= \tau_w \times \text{area of pipe wall} \\ &= \tau_w \pi d L \end{aligned}$$

As the flow is in equilibrium,

driving force = retarding force

$$\begin{aligned} \Delta p \frac{\pi d^2}{4} &= \tau_w \pi d L \\ \Delta p &= \frac{\tau_w 4L}{d} \end{aligned}$$

Giving pressure loss in a pipe in terms of:

- pipe diameter
- shear stress at the wall

What is the variation of shear stress in the flow?

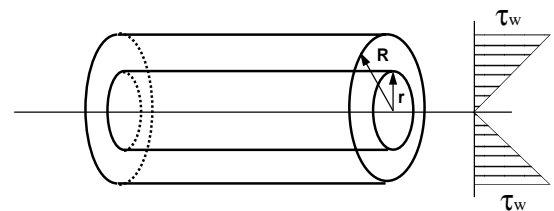

At the wall

$$\tau_w = \frac{R \Delta p}{2 L}$$

At a radius  $r$

$$\tau = \frac{r \Delta p}{2 L}$$

$$\tau = \tau_w \frac{r}{R}$$

A linear variation in shear stress.

This is valid for:

- steady flow
- laminar flow
- turbulent flow

Shear stress and hence pressure loss varies with velocity of flow and hence with Re.

Many experiments have been done with various fluids measuring the pressure loss at various Reynolds numbers.

A graph of pressure loss and Re look like:

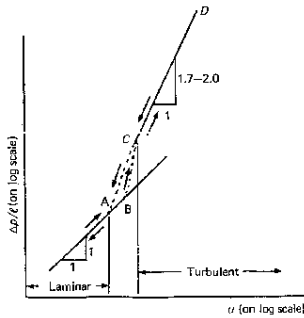

This graph shows that the relationship between pressure loss and Re can be expressed as

$$\text{laminar} \quad \Delta p \propto u$$

$$\text{turbulent} \quad \Delta p \propto u^{1.7} \text{ (or } 2.0)$$

### Pressure loss during laminar flow in a pipe

In general the shear stress  $\tau_w$  is almost impossible to measure.

For laminar flow we can calculate a theoretical value for a given velocity, fluid and pipe dimension.

In laminar flow the paths of individual particles of fluid do not cross.

Flow is like a series of concentric cylinders sliding over each other.

And the stress on the fluid in laminar flow is entirely due to viscose forces.

As before, consider a cylinder of fluid, length L, radius r, flowing steadily in the centre of a pipe.

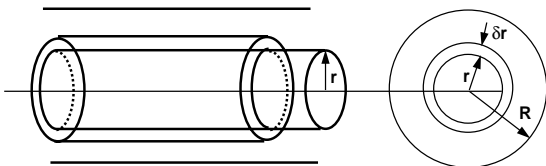

The fluid is in equilibrium, shearing forces equal the pressure forces.

$$\tau 2\pi r L = \Delta p A = \Delta p \pi r^2$$

$$\tau = \frac{\Delta p r}{L 2}$$

Newtons law of viscosity says  $\tau = \mu \frac{du}{dy}$ ,

We are measuring from the pipe centre, so

$$\tau = -\mu \frac{du}{dr}$$

Giving:

$$\frac{\Delta p r}{L 2} = -\mu \frac{du}{dr}$$

$$\frac{du}{dr} = -\frac{\Delta p r}{L 2\mu}$$

In an integral form this gives an expression for velocity,

$$u = -\frac{\Delta p}{L} \frac{1}{2\mu} \int r dr$$

The value of velocity at a point distance r from the centre

$$u_r = -\frac{\Delta p}{L} \frac{r^2}{4\mu} + C$$

At  $r = 0$ , (the centre of the pipe),  $u = u_{max}$ , at  $r = R$  (the pipe wall)  $u = 0$ ;

$$C = \frac{\Delta p}{L} \frac{R^2}{4\mu}$$

At a point r from the pipe centre when the flow is laminar:

$$u_r = \frac{\Delta p}{L} \frac{1}{4\mu} (R^2 - r^2)$$

This is a parabolic profile (of the form  $y = ax^2 + b$ ) so the velocity profile in the pipe looks similar to

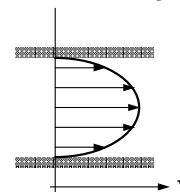

### What is the discharge in the pipe?

The flow in an annulus of thickness  $\delta r$

$$\delta Q = u_r A_{annulus}$$

$$A_{annulus} = \pi(r + \delta r)^2 - \pi r^2 \approx 2\pi r \delta r$$

$$\delta Q = \frac{\Delta p}{L} \frac{1}{4\mu} (R^2 - r^2) 2\pi r \delta r$$

$$Q = \frac{\Delta p}{L} \frac{\pi}{2\mu} \int_0^R (R^2 r - r^3) dr$$

$$= \frac{\Delta p}{L} \frac{\pi R^4}{8\mu} = \frac{\Delta p \pi d^4}{128\mu}$$

So the discharge can be written

$$Q = \frac{\Delta p \pi d^4}{L 128\mu}$$

This is the Hagen-Poiseuille Equation  
for laminar flow in a pipe

To get pressure loss (head loss)  
in terms of the velocity of the flow, write  
pressure in terms of head loss  $h_f$ , i.e.  $p = \rho g h_f$

Mean velocity:

$$u = Q / A$$

$$u = \frac{\rho g h_f d^2}{32\mu L}$$

Head loss in a pipe with laminar flow by the  
Hagen-Poiseuille equation:

$$h_f = \frac{32\mu L u}{\rho g d^2}$$

Pressure loss is directly proportional to the  
velocity when flow is laminar.

It has been validated many time by experiment.

It justifies two assumptions:

1. fluid does not slip past a solid boundary
2. Newtons hypothesis.

### Boundary Layers

Recommended reading: Fluid Mechanics  
by Douglas J F, Gasiorek J M, and Swaffield J A.  
Longman publishers. Pages 327-332.

Fluid flowing over a stationary surface,  
e.g. the bed of a river, or the wall of a pipe,  
is brought to rest by the shear stress  $\tau_0$ .

This gives a, now familiar, velocity profile:

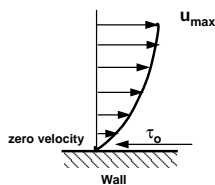

Zero at the wall  
A maximum at the centre of the flow.

The profile doesn't just exit.  
It is build up gradually.

Starting when it first flows past the surface  
e.g. when it enters a pipe.

Considering a flat plate in a fluid.

Upstream the velocity profile is uniform,  
This is known as free stream flow.

Downstream a velocity profile exists.  
This is known as fully developed flow.

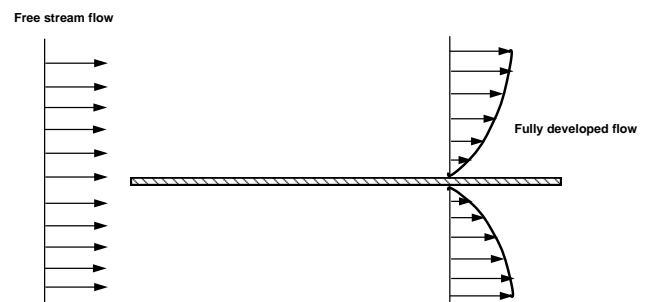

Some question we might ask:

- How do we get to the fully developed state?
- Are there any changes in flow as we get there?
- Are the changes significant / important?

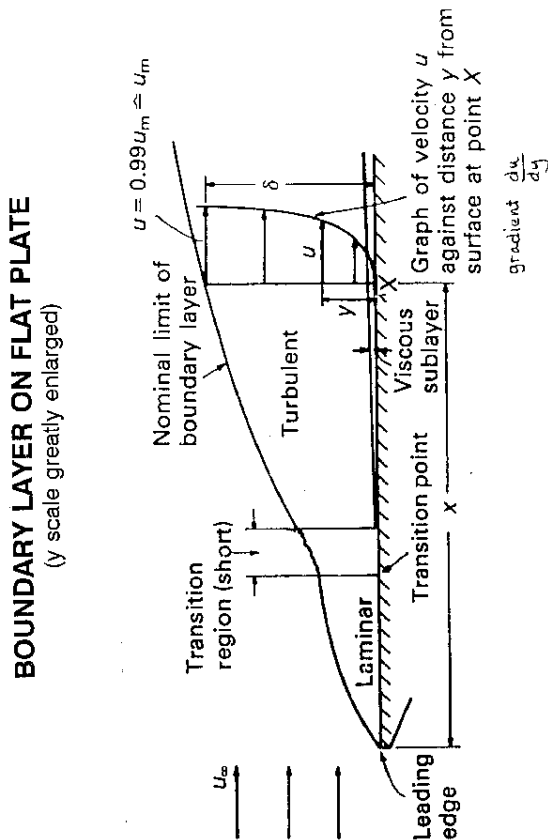
**Understand this Boundary layer growth diagram.****Boundary layer thickness:**

$\delta =$  distance from wall to where  $u = 0.99 u_{\text{mainstream}}$

$\delta$  increases as fluid moves along the plate.  
It reaches a maximum in fully developed flow.

The  $\delta$  increase corresponds to a drag force increase on the fluid.

As fluid is passes over a greater length:

- \* more fluid is slowed
- \* by friction between the fluid layers
- \* the thickness of the slow layer increases.

Fluid near the top of the boundary layer drags the fluid nearer to the solid surface along.

The mechanism for this dragging may be one of two types:

**First: viscous forces**  
(the forces which hold the fluid together)

When the boundary layer is thin:  
velocity gradient  $du/dy$ , is large

by Newton's law of viscosity  
shear stress,  $\tau = \mu (du/dy)$ , is large.

The force may be large enough to drag the fluid close to the surface.

As the boundary layer thickens  
velocity gradient reduces and  
shear stress decreases.

Eventually it is too small  
to drag the slow fluid along.

Up to this point the flow has been laminar.

Newton's law of viscosity has applied.

This part of the boundary layer is the  
laminar boundary layer

**Second: momentum transfer**

If the viscous forces were the only action  
the fluid would come to a rest.

Viscous shear stresses have held the fluid  
particles in a constant motion within layers.

Eventually they become too small  
to hold the flow in layers;

the fluid starts to rotate.

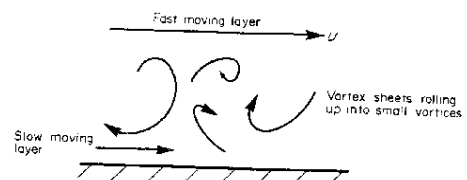

The fluid motion rapidly becomes turbulent.  
Momentum transfer occurs between fast moving  
main flow and slow moving near wall flow.  
Thus the fluid by the wall is kept in motion.  
The net effect is an increase in momentum in the  
boundary layer.

This is the turbulent boundary layer.

Close to boundary velocity gradients are very large.  
Viscous shear forces are large.  
Possibly large enough to cause laminar flow.  
This region is known as the laminar sub-layer.

This layer occurs within the turbulent zone  
it is next to the wall.  
It is very thin – a few hundredths of a mm.

### Surface roughness effect

Despite its thinness, the laminar sub-layer has vital role in the friction characteristics of the surface.

In turbulent flow:  
Roughness higher than laminar sub-layer:  
increases turbulence and energy losses.

In laminar flow:  
Roughness has very little effect

### Boundary layers in pipes Initially of the laminar form.

It changes depending on the ratio of inertial and viscous forces;

i.e. whether we have laminar (viscous forces high) or turbulent flow (inertial forces high).

Use Reynolds number to determine which state.

$$Re = \frac{\rho u d}{\mu}$$

Laminar flow:  $Re < 2000$

Transitional flow:  $2000 < Re < 4000$

Turbulent flow:  $Re > 4000$

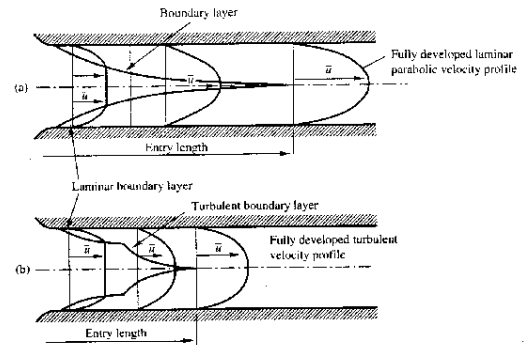

Laminar flow: profile parabolic (proved in earlier lectures)  
The first part of the boundary layer growth diagram.

Turbulent (or transitional),  
Laminar and the turbulent (transitional) zones of the  
boundary layer growth diagram.

Length of pipe for fully developed flow is  
the entry length.

Laminar flow  $\approx 120 \times \text{diameter}$

Turbulent flow  $\approx 60 \times \text{diameter}$

### Boundary layer separation

Divergent flows:

Positive pressure gradients.  
Pressure increases in the direction of flow.

The fluid in the boundary layer has so little momentum that it is brought to rest,  
and possibly reversed in direction.

Reversal lifts the boundary layer.

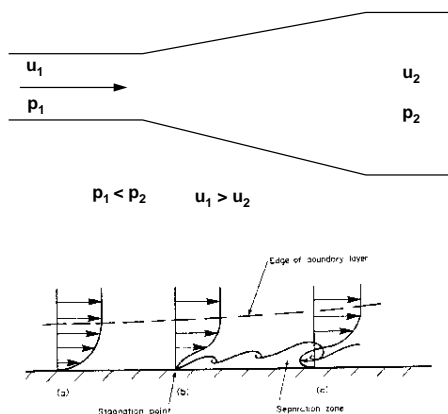

This phenomenon is known as  
boundary layer separation.

Boundary layer separation:

- \* increases the turbulence
- \* increases the energy losses in the flow.

Separating / divergent flows are inherently  
unstable

Convergent flows:

- Negative pressure gradients
- Pressure decreases in the direction of flow.
- Fluid accelerates and the boundary layer is thinner.

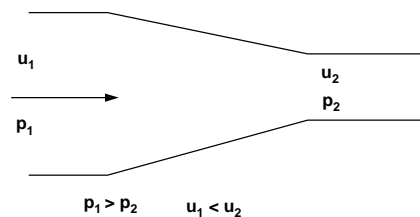

• Flow remains stable

• Turbulence reduces.

• Boundary layer separation does not occur.

## Examples of boundary layer separation

### A divergent duct or diffuser

velocity drop  
(according to continuity)  
pressure increase  
(according to the Bernoulli equation).

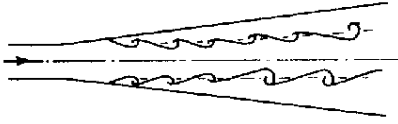

Increasing the angle increases the probability of boundary layer separation.

### Venturi meter

Diffuser angle of about  $6^\circ$

A balance between:

- \* length of meter
- \* danger of boundary layer separation.

## Tee-Junctions

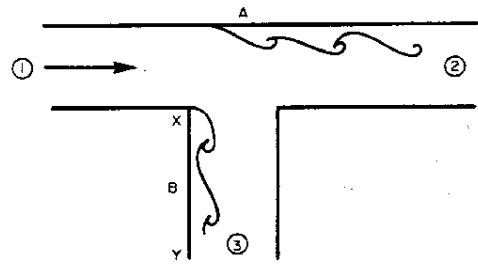

Assuming equal sized pipes),  
Velocities at 2 and 3 are smaller than at 1.  
Pressure at 2 and 3 are higher than at 1.  
Causing the two separations shown

## Y-Junctions

Tee junctions are special cases of the Y-junction.

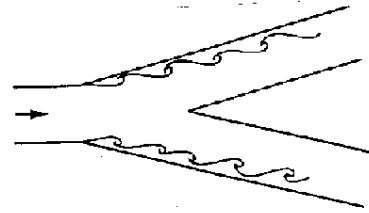

## Bends

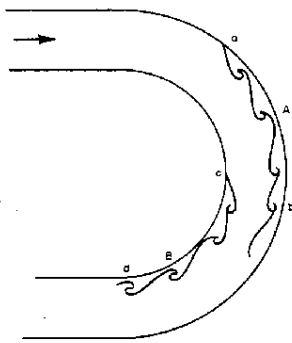

Two separation zones occur in bends as shown above.

$P_b > P_a$  causing separation.

$P_d > P_c$  causing separation

### Localised effect

Downstream the boundary layer reattaches and normal flow occurs.

Boundary layer separation is only local.

Nevertheless downstream of a junction / bend / valve etc. fluid will have lost energy.

## Flow past a cylinder

Slow flow,  $Re < 0.5$  no separation:

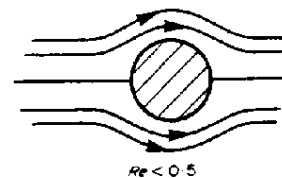

Moderate flow,  $Re < 70$ , separation vortices form.

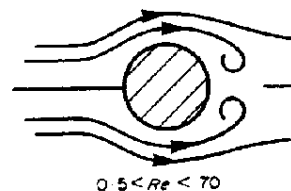

Fast flow  $Re > 70$   
vortices detach alternately.

Form a trail of down stream.

Karman vortex trail or street.  
(Easily seen by looking over a bridge)

Causes whistling in power cables.

Caused Tacoma narrows bridge to collapse.

Frequency of detachment was equal to the bridge natural frequency.

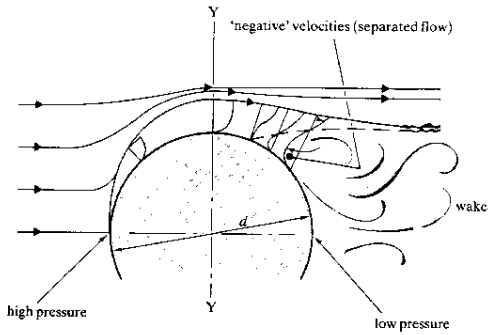

Fluid accelerates to get round the cylinder  
Velocity maximum at Y.  
Pressure dropped.

Adverse pressure between here and downstream.  
Separation occurs

**Aerofoil**  
Normal flow over a aerofoil or a wing cross-section.

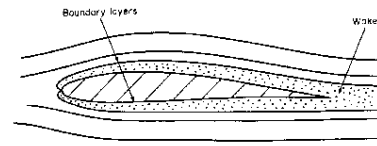

(boundary layers greatly exaggerated)

The velocity increases as air flows over the wing. The pressure distribution is as below so transverse lift force occurs.

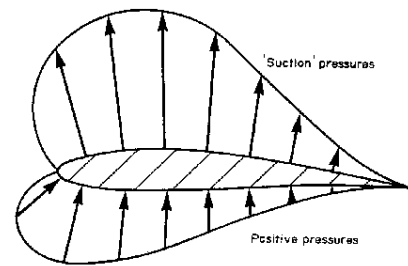

At too great an angle  
boundary layer separation occurs on the top  
Pressure changes dramatically.  
This phenomenon is known as stalling.

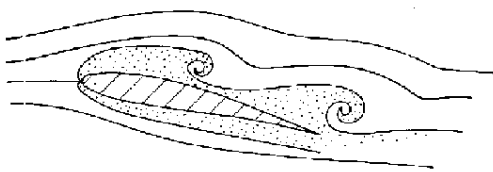

All, or most, of the 'suction' pressure is lost.  
The plane will suddenly drop from the sky!

Solution:

Prevent separation.

- 1 Engine intakes draws slow air from the boundary layer at the rear of the wing through small holes
- 2 Move fast air from below to top via a slot.

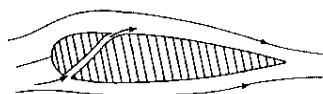

- 3 Put a flap on the end of the wing and tilt it.

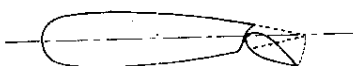

**Examples:**

Exam questions involving boundary layer theory are typically descriptive. They ask you to explain the mechanisms of growth of the boundary layers including how, why and where separation occurs. You should also be able to suggest what might be done to prevent separation.

**Lectures 18 & 19: Dimensional Analysis**  
Unit 4: The Effect of the Boundary on Flow

Application of fluid mechanics in design makes use of experiments results.

Results often difficult to interpret.

Dimensional analysis provides a strategy for choosing relevant data.

Used to help analyse fluid flow

Especially when fluid flow is too complex for mathematical analysis.

Specific uses:

- help design experiments
- Informs which measurements are important
- Allows most to be obtained from experiment:  
e.g. What runs to do. How to interpret.

It depends on the correct identification of variables

Relates these variables together

Doesn't give the complete answer

Experiments necessary to complete solution

Uses principle of dimensional homogeneity  
It gives qualitative results which only become quantitative from experimental analysis.

Dimensions and units

Any physical situation  
can be described by familiar properties.

e.g. length, velocity, area, volume, acceleration etc.

These are all known as dimensions.

Dimensions are of no use without a magnitude.

i.e. a standardised unit

e.g. metre, kilometre, Kilogram, a yard etc.

Dimensions can be measured.

Units used to quantify these dimensions.

In dimensional analysis we are concerned with the nature of the dimension

i.e. its quality not its quantity.

The following common abbreviations are used:

length	= L
mass	= M
time	= T
force	= F
temperature	= $\Theta$

Here we will use L, M, T and F (not  $\Theta$ ).

We can represent all the physical properties we are interested in with three:

L, T  
and one of M or F

As either mass (M) or force (F) can be used to represent the other, i.e.

$$F = MLT^{-2}$$

$$M = FT^2L^{-1}$$

We will mostly use LTM:

This table lists dimensions of some common physical quantities:

Quantity	SI Unit		Dimension
velocity	m/s	ms <sup>-1</sup>	LT <sup>-1</sup>
acceleration	m/s <sup>2</sup>	ms <sup>-2</sup>	LT <sup>-2</sup>
force	N kg m/s <sup>2</sup>	kg ms <sup>-2</sup>	MLT <sup>-2</sup>
energy (or work)	Joule J N m, kg m <sup>2</sup> /s <sup>2</sup>	kg m <sup>2</sup> s <sup>-2</sup>	ML <sup>2</sup> T <sup>-2</sup>
power	Watt W N m/s kg m <sup>2</sup> /s <sup>3</sup>	Nms <sup>-1</sup> kg m <sup>2</sup> s <sup>-3</sup>	ML <sup>2</sup> T <sup>-3</sup>
pressure ( or stress)	Pascal P, N/m <sup>2</sup> , kg/m/s <sup>2</sup>	Nm <sup>-2</sup> kg m <sup>-1</sup> s <sup>-2</sup>	ML <sup>-1</sup> T <sup>-2</sup>
density	kg/m <sup>3</sup>	kg m <sup>-3</sup>	ML <sup>-3</sup>
specific weight	N/m <sup>3</sup> kg/m <sup>2</sup> /s <sup>2</sup>	kg m <sup>-2</sup> s <sup>-2</sup>	ML <sup>-2</sup> T <sup>-2</sup>
relative density	a ratio no units		1 no dimension
viscosity	N s/m <sup>2</sup> kg/m s	N sm <sup>-2</sup> kg m <sup>-1</sup> s <sup>-1</sup>	ML <sup>-1</sup> T <sup>-1</sup>
surface tension	N/m kg /s <sup>2</sup>	Nm <sup>-1</sup> kg s <sup>-2</sup>	MT <sup>-2</sup>

## Dimensional Homogeneity

Any equation is only true if both sides have the same dimensions.

It must be dimensionally homogenous.

What are the dimensions of X?

$$\frac{2}{3} B \sqrt{2g} H^{3/2} = X$$

$$L (L T^{-2})^{1/2} L^{3/2} = X$$

$$L (L^{1/2} T^{-1}) L^{3/2} = X$$

$$L^3 T^{-1} = X$$

The powers of the individual dimensions must be equal on both sides.

(for L they are both 3, for T both -1).

Dimensional homogeneity can be useful for:

1. Checking units of equations;
2. Converting between two sets of units;
3. Defining dimensionless relationships

## What exactly do we get from Dimensional Analysis?

A single equation,

Which relates all the physical factors of a problem to each other.

An example:

Problem: What is the force, F, on a propeller?

What *might* influence the force?

It would be reasonable to assume that the force, F, depends on the following physical properties?

diameter,  $d$

forward velocity of the propeller  
(velocity of the plane),  $u$

fluid density,  $\rho$

revolutions per second,  $N$

fluid viscosity,  $\mu$

From this list we can write this equation:

$$F = \phi (d, u, \rho, N, \mu)$$

or

$$0 = \phi_1 (F, d, u, \rho, N, \mu)$$

$\phi$  and  $\phi_1$  are unknown functions.

Dimensional Analysis produces:

$$\phi \left( \frac{F}{\rho u^2 d^2}, \frac{Nd}{u}, \frac{\mu}{\rho u d} \right) = 0$$

These groups are *dimensionless*.  
 $\phi$  will be determined by experiment.

These dimensionless groups help to decide what experimental measurements to take.

## How do we get the dimensionless groups?

There are several methods.

We will use the strategic method based on:

Buckingham's  $\pi$  theorems.

There are two  $\pi$  theorems:

1<sup>st</sup>  $\pi$  theorem:

A relationship between m variables (physical properties such as velocity, density etc.) can be expressed as a relationship between m-n *non-dimensional* groups of variables (called  $\pi$  groups), where n is the number of fundamental dimensions (such as mass, length and time) required to express the variables.

So if a problem is expressed:

$$\phi (Q_1, Q_2, Q_3, \dots, Q_m) = 0$$

Then this can also be expressed

$$\phi (\pi_1, \pi_2, \pi_3, \dots, \pi_{m-n}) = 0$$

In fluids, we can normally take n = 3  
(corresponding to M, L, T)

**2<sup>nd</sup>  $\pi$  theorem**

Each  $\pi$  group is a function of  $n$  governing or repeating variables plus one of the remaining variables.

Choice of repeating variables

Repeating variables appear in most of the  $\pi$  groups.

They have a large influence on the problem.

There is great freedom in choosing these.

Some rules which should be followed are

- There are  $n$  ( $= 3$ ) repeating variables.
- In combination they must contain all of dimensions (M, L, T)
- The repeating variables must not form a dimensionless group.
- They do not have to appear in all  $\pi$  groups.
- They should be measurable in an experiment.
- They should be of major interest to the designer.

It is usually possible to take  
 $\rho$ ,  $u$  and  $d$

This freedom of choice means:  
many different  $\pi$  groups - all are valid.  
There is not really a wrong choice.

An example

Taking the example discussed above of force  $F$  induced on a propeller blade, we have the equation

$$0 = \phi(F, d, u, \rho, N, \mu)$$

$$n = 3 \text{ and } m = 6$$

There are  $m - n = 3$   $\pi$  groups, so

$$\phi(\pi_1, \pi_2, \pi_3) = 0$$

The choice of  $\rho$ ,  $u$ ,  $d$  satisfies the criteria above.

They are:

- measurable,
- good design parameters
- contain all the dimensions M, L and T.

We can now form the three groups according to the 2nd theorem,

$$\pi_1 = \rho^{a_1} u^{b_1} d^{c_1} F$$

$$\pi_2 = \rho^{a_2} u^{b_2} d^{c_2} N$$

$$\pi_3 = \rho^{a_3} u^{b_3} d^{c_3} \mu$$

The  $\pi$  groups are all dimensionless,  
i.e. they have dimensions  $M^0 L^0 T^0$

We use the principle of dimensional homogeneity to equate the dimensions for each  $\pi$  group.

For the first  $\pi$  group,  $\pi_1 = \rho^{a_1} u^{b_1} d^{c_1} F$

In terms of dimensions

$$M^0 L^0 T^0 = (M L^{-3})^{a_1} (L T^{-1})^{b_1} (L)^{c_1} M L T^{-2}$$

The powers for each dimension (M, L or T), the powers must be equal on each side.

for M:  $0 = a_1 + 1$   
 $a_1 = -1$

for L:  $0 = -3a_1 + b_1 + c_1 + 1$   
 $0 = 4 + b_1 + c_1$

for T:  $0 = -b_1 - 2$   
 $b_1 = -2$   
 $c_1 = -4 - b_1 = -2$

Giving  $\pi_1$  as

$$\pi_1 = \rho^{-1} u^{-2} d^{-2} F$$

$$\pi_1 = \frac{F}{\rho u^2 d^2}$$

And a similar procedure is followed for the other  $\pi$  groups.

Group  $\pi_2 = \rho^{a_2} u^{b_2} d^{c_2} N$

$$M^0 L^0 T^0 = (ML^{-3})^{a_1} (LT^{-1})^{b_1} (L)^{c_1} T^{-1}$$

for M:  $0 = a_2$

for L:  $0 = -3a_2 + b_2 + c_2$   
 $0 = b_2 + c_2$

for T:  $0 = -b_2 - 1$   
 $b_2 = -1$   
 $c_2 = 1$

Giving  $\pi_2$  as

$$\pi_2 = \rho^0 u^{-1} d^1 N$$

$$\pi_2 = \frac{Nd}{u}$$

And for the third,  $\pi_3 = \rho^{a_3} u^{b_3} d^{c_3} \mu$

$$M^0 L^0 T^0 = (ML^{-3})^{a_3} (LT^{-1})^{b_3} (L)^{c_3} ML^{-1} T^{-1}$$

for M:  $0 = a_3 + 1$   
 $a_3 = -1$

for L:  $0 = -3a_3 + b_3 + c_3 - 1$   
 $b_3 + c_3 = -2$

for T:  $0 = -b_3 - 1$   
 $b_3 = -1$   
 $c_3 = -1$

Giving  $\pi_3$  as

$$\pi_3 = \rho^{-1} u^{-1} d^{-1} \mu$$

$$\pi_3 = \frac{\mu}{\rho u d}$$

Thus the problem may be described by

$$\phi(\pi_1, \pi_2, \pi_3) = 0$$

$$\phi\left(\frac{F}{\rho u^2 d^2}, \frac{Nd}{u}, \frac{\mu}{\rho u d}\right) = 0$$

This may also be written:

$$\frac{F}{\rho u^2 d^2} = \phi\left(\frac{Nd}{u}, \frac{\mu}{\rho u d}\right)$$

### Wrong choice of physical properties.

If, extra, unimportant variables are chosen :

- \* Extra  $\pi$  groups will be formed
- \* Will have little effect on physical performance
- \* Should be identified during experiments

If an important variable is missed:

- A  $\pi$  group would be missing.
- Experimental analysis may miss significant behavioural changes.

Initial choice of variables should be done with great care.

### Manipulation of the $\pi$ groups

Once identified the  $\pi$  groups can be changed.

The number of groups does not change.

Their appearance may change drastically.

Taking the defining equation as:

$$\phi(\pi_1, \pi_2, \pi_3, \dots, \pi_{m-n}) = 0$$

The following changes are permitted:

- i. Combination of existing groups by multiplication or division to form a new group to replace one of the existing.

E.g.  $\pi_1$  and  $\pi_2$  may be combined to form  $\pi_{1a} = \pi_1 / \pi_2$  so the defining equation becomes

$$\phi(\pi_{1a}, \pi_2, \pi_3, \dots, \pi_{m-n}) = 0$$

- ii. Reciprocal of any group is valid.

$$\phi(\pi_1, 1/\pi_2, \pi_3, \dots, 1/\pi_{m-n}) = 0$$

- iii. A group may be raised to any power.

$$\phi((\pi_1)^2, (\pi_2)^{1/2}, (\pi_3)^3, \dots, \pi_{m-n}) = 0$$

- iv. Multiplied by a constant.

- v. Expressed as a function of the other groups

$$\pi_2 = \phi(\pi_1, \pi_3, \dots, \pi_{m-n})$$

In general the defining equation could look like

$$\phi(\pi_1, 1/\pi_2, (\pi_3)^2, \dots, 0.5\pi_{m-n}) = 0$$

An Example

Q. If we have a function describing a problem:

$$\phi(Q, d, \rho, \mu, p) = 0$$

Show that  $Q = \frac{d^2 p^{1/2}}{\rho^{1/2}} \phi\left(\frac{d\rho^{1/2} p^{1/2}}{\mu}\right)$

Ans.

Dimensional analysis using  $Q, \rho, d$  will result in:

$$\phi\left(\frac{d\mu}{Q\rho}, \frac{d^4 p}{\rho Q^2}\right) = 0$$

The reciprocal of square root of  $\pi_2$ :

$$\frac{1}{\sqrt{\pi_2}} = \frac{\rho^{1/2} Q}{d^2 p^{1/2}} = \pi_{2a},$$

Multiply  $\pi_1$  by this new group:

$$\pi_{1a} = \pi_1 \pi_{2a} = \frac{d\mu \rho^{1/2} Q}{Q\rho d^2 p^{1/2}} = \frac{\mu}{d\rho^{1/2} p^{1/2}}$$

then we can say

$$\phi(1/\pi_{1a}, \pi_{2a}) = \phi\left(\frac{d\rho^{1/2} p^{1/2}}{\mu}, \frac{d^2 p^{1/2}}{Q\rho^{1/2}}\right) = 0$$

or

$$Q = \frac{d^2 p^{1/2}}{\rho^{1/2}} \phi\left(\frac{d\rho^{1/2} p^{1/2}}{\mu}\right)$$

Common  $\pi$  groups

Several groups will appear again and again.

These often have names.

They can be related to physical forces.

Other common non-dimensional numbers  
or ( $\pi$  groups):

Reynolds number:

$$Re = \frac{\rho u d}{\mu} \quad \text{inertial, viscous force ratio}$$

Euler number:

$$En = \frac{p}{\rho u^2} \quad \text{pressure, inertial force ratio}$$

Froude number:

$$Fn = \frac{u^2}{gd} \quad \text{inertial, gravitational force ratio}$$

Weber number:

$$We = \frac{\rho u d}{\sigma} \quad \text{inertial, surface tension force ratio}$$

Mach number:

$$Mn = \frac{u}{c} \quad \text{Local velocity, local velocity of sound ratio}$$

Similarity

Similarity is concerned with how to transfer measurements from models to the full scale.

Three types of similarity  
which exist between a model and prototype:

Geometric similarity:

The ratio of all corresponding dimensions  
in the model and prototype are equal.

For lengths

$$\frac{L_{\text{model}}}{L_{\text{prototype}}} = \frac{L_m}{L_p} = \lambda_L$$

$\lambda_L$  is the scale factor for length.

For areas

$$\frac{A_{\text{model}}}{A_{\text{prototype}}} = \frac{L_m^2}{L_p^2} = \lambda_L^2$$

All corresponding angles are the same.

Kinematic similarity

The similarity of time as well as geometry.

It exists if:

- the paths of particles are geometrically similar
- the ratios of the velocities of are similar

Some useful ratios are:

$$\text{Velocity} \quad \frac{V_m}{V_p} = \frac{L_m / T_m}{L_p / T_p} = \frac{\lambda_L}{\lambda_T} = \lambda_u$$

$$\text{Acceleration} \quad \frac{a_m}{a_p} = \frac{L_m / T_m^2}{L_p / T_p^2} = \frac{\lambda_L}{\lambda_T^2} = \lambda_a$$

$$\text{Discharge} \quad \frac{Q_m}{Q_p} = \frac{L_m^3 / T_m}{L_p^3 / T_p} = \frac{\lambda_L^3}{\lambda_T} = \lambda_Q$$

A consequence is that streamline  
patterns are the same.

Dynamic similarity

If geometrically and kinematically similar and the ratios of all forces are the same.

Force ratio

$$\frac{F_m}{F_p} = \frac{M_m a_m}{M_p a_p} = \frac{\rho_m L_m^3}{\rho_p L_p^3} \times \frac{\lambda_L}{\lambda_T} = \lambda_\rho \lambda_L^2 \left(\frac{\lambda_L}{\lambda_T}\right)^2 = \lambda_\rho \lambda_L^2 \lambda_u^2$$

This occurs when the controlling  $\pi$  group is the same for model and prototype.

The controlling  $\pi$  group is usually  $Re$ . So  $Re$  is the same for model and prototype:

$$\frac{\rho_m u_m d_m}{\mu_m} = \frac{\rho_p u_p d_p}{\mu_p}$$

It is possible another group is dominant. In open channel i.e. river Froude number is often taken as dominant.

Modelling and Scaling Laws

Measurements taken from a model needs a scaling law applied to predict the values in the prototype.

An example:

For resistance  $R$ , of a body moving through a fluid.

$R$ , is dependent on the following:

$$\rho: ML^{-3} \quad u: LT^{-1} \quad l:(length) L \quad \mu: ML^{-1}T^{-1}$$

So

$$\phi(R, \rho, u, l, \mu) = 0$$

Taking  $\rho, u, l$  as repeating variables gives:

$$\frac{R}{\rho u^2 l^2} = \phi\left(\frac{\rho u l}{\mu}\right)$$

$$R = \rho u^2 l^2 \phi\left(\frac{\rho u l}{\mu}\right)$$

This applies whatever the size of the body i.e. it is applicable to prototype and a geometrically similar model.

For the model

$$\frac{R_m}{\rho_m u_m^2 l_m^2} = \phi\left(\frac{\rho_m u_m l_m}{\mu_m}\right)$$

and for the prototype

$$\frac{R_p}{\rho_p u_p^2 l_p^2} = \phi\left(\frac{\rho_p u_p l_p}{\mu_p}\right)$$

Dividing these two equations gives

$$\frac{R_m / \rho_m u_m^2 l_m^2}{R_p / \rho_p u_p^2 l_p^2} = \frac{\phi(\rho_m u_m l_m / \mu_m)}{\phi(\rho_p u_p l_p / \mu_p)}$$

We can go no further without some assumptions.

Assuming dynamic similarity, so Reynolds number are the same for both the model and prototype:

$$\frac{\rho_m u_m d_m}{\mu_m} = \frac{\rho_p u_p d_p}{\mu_p}$$

so

$$\frac{R_m}{R_p} = \frac{\rho_m u_m^2 l_m^2}{\rho_p u_p^2 l_p^2}$$

i.e. a scaling law for resistance force:

$$\lambda_R = \lambda_\rho \lambda_u^2 \lambda_L^2$$

Example 1

An underwater missile, diameter 2m and length 10m is tested in a water tunnel to determine the forces acting on the real prototype. A 1/20<sup>th</sup> scale model is to be used. If the maximum allowable speed of the prototype missile is 10 m/s, what should be the speed of the water in the tunnel to achieve dynamic similarity?

Dynamic similarity so Reynolds numbers equal:

$$\frac{\rho_m u_m d_m}{\mu_m} = \frac{\rho_p u_p d_p}{\mu_p}$$

The model velocity should be

$$u_m = u_p \frac{\rho_p d_p \mu_m}{\rho_m d_m \mu_p}$$

Both the model and prototype are in water then,

$$\mu_m = \mu_p \text{ and } \rho_m = \rho_p \text{ so}$$

$$u_m = u_p \frac{d_p}{d_m} = 10 \frac{1}{1/20} = 200 \text{ m/s}$$

This is a very high velocity.

This is one reason why model tests are not always done at exactly equal Reynolds numbers.

A wind tunnel could have been used so the values of the  $\rho$  and  $\mu$  ratios would be used in the above.

Example 2

A model aeroplane is built at 1/10 scale and is to be tested in a wind tunnel operating at a pressure of 20 times atmospheric. The aeroplane will fly at 500km/h. At what speed should the wind tunnel operate to give dynamic similarity between the model and prototype? If the drag measure on the model is 337.5 N what will be the drag on the plane?

Earlier we derived an equation for resistance on a body moving through air:

$$R = \rho u^2 l^2 \phi \left( \frac{\rho u l}{\mu} \right) = \rho u^2 l^2 \phi(\text{Re})$$

For dynamic similarity  $\text{Re}_m = \text{Re}_p$ , so

$$u_m = u_p \frac{\rho_p d_p \mu_m}{\rho_m d_m \mu_p}$$

The value of  $\mu$  does not change much with pressure so  $\mu_m = \mu_p$

For an ideal gas is  $p = \rho RT$  so the density of the air in the model can be obtained from

$$\frac{p_m}{\rho_p} = \frac{\rho_m RT}{\rho_p RT} = \frac{\rho_m}{\rho_p}$$

$$\frac{20 p_p}{\rho_p} = \frac{\rho_m}{\rho_p}$$

$$\rho_m = 20 \rho_p$$

So the model velocity is found to be

$$u_m = u_p \frac{1}{20} \frac{1}{10} = 0.5 u_p$$

$$u_m = 250 \text{ km/h}$$

And the ratio of forces is

$$\frac{R_m}{R_p} = \frac{(\rho u^2 l^2)_m}{(\rho u^2 l^2)_p}$$

$$\frac{R_m}{R_p} = \frac{20 (0.5)^2 (0.1)^2}{1 \cdot 1 \cdot 1} = 0.05$$

So the drag force on the prototype will be

$$R_p = \frac{1}{0.05} R_m = 20 \times 337.5 = 6750 \text{ N}$$

Geometric distortion in river models

For practical reasons it is difficult to build a geometrically similar model.

A model with suitable depth of flow will often be far too big - take up too much floor space.

Keeping Geometric Similarity result in:

- depths and become very difficult to measure;
- the bed roughness becomes impracticably small;
- laminar flow may occur - (turbulent flow is normal in rivers.)

Solution: Abandon geometric similarity.

Typical values are

1/100 in the vertical and 1/400 in the horizontal.

Resulting in:

- Good overall flow patterns and discharge
- local detail of flow is not well modelled.

The Froude number (Fn) is taken as dominant.

Fn can be the same even for distorted models.