

UNIFIED FACILITIES CRITERIA (UFC)

INDUSTRIAL VENTILATION



APPROVED FOR PUBLIC RELEASE; DISTRIBUTION UNLIMITED

Contents

	Page
CHAPTER 1 INTRODUCTION	
1-1	SCOPE 1-1
1-2	PURPOSE OF CRITERIA 1-1
1-3	SPECIFIC PROCESSES 1-1
CHAPTER 2 GENERAL REQUIREMENTS	
2-1	GENERAL CRITERIA 2-1
2-2	COORDINATION 2-1
2-3	DESIGN PROCEDURE 2-1
2-3.1	Step 1 2-1
2-3.2	Step 2 2-2
2-3.3	Step 3 2-2
2-3.4	Step 4 2-2
2-3.5	Step 5 2-2
2-3.6	Step 6 2-2
2-3.7	Step 7 2-2
2-3.8	Step 8 2-2
2-4	DESIGN CRITERIA 2-2
2-4.1	Ductwork 2-2
2-4.2	Fans 2-3
2-4.3	Exhaust stacks 2-4
2-4.4	Air Pollution Control Equipment 2-4
2-4.5	Replacement Air 2-4
2-5	CONTROLS 2-7
2-5.1	Gauges and Sensors 2-7
2-5.2	Interlocks 2-8
2-5.3	Annunciator Panel 2-8
2-6	OPERATIONAL CONSIDERATIONS 2-9
2-6.1	Provision for System Testing 2-9
2-6.2	Energy Conservation 2-9
2-6.3	Recirculation 2-9
2-6.4	Maintenance 2-10
2-7	SAFETY AND HEALTH CONSIDERATIONS 2-10
2-7.1	Posting 2-10
2-7.2	Noise 2-10
2-7.3	Respiratory Protection 2-10
2-7.4	Emergency Showers and Eyewash Stations 2-11
2-7.5	Hygiene Facilities 2-11
2-8	COMMISSIONING 2-11
CHAPTER 3 ASBESTOS DELAGGING FACILITIES	

3-1	FUNCTION	3-1
3-2	OPERATIONAL CONSIDERATIONS	3-1
3-2.1	Airborne Contamination	3-1
3-2.2	Heat Stress	3-1
3-2.3	Employee Workflow	3-1
3-3	TYPICAL FLOOR PLANS	3-1
3-4	DESIGN CRITERIA	3-2
3-5	EXHAUST AIR	3-2
3-5.1	Hood Design	3-2
3-5.3	Ductwork	3-3
3-5.4	Fans	3-4
3-5.5	Weather Stack Design and Location	3-4
3-5.6	Air Cleaning Devices	3-4
3-5.7	Industrial Vacuum System	3-5
3-5.8	Replacement Air	3-7
3-5.9	System Controls	3-7
3-6	SAFETY AND HEALTH CONSIDERATIONS	3-8

CHAPTER 4 OTTO FUEL II FACILITIES

4-1	FUNCTION	4-1
4-2	OPERATIONAL CONSIDERATIONS	4-1
4-3	DESIGN CRITERIA	4-1
4.3.1	Exhaust Air for MK-46 Ventilated Spaces	4-1
4-3.2	Exhaust Air for MK-48 Ventilated Spaces	4-5
4-3.3	Weather Stack Design and Location	4-9
4-3.4	Air Cleaning Devices	4-9
4-3.5	Replacement Air	4-9
4-3.6	Heating and Air Conditioning	4-11
4-4	SYSTEM CONTROLS	4-11
4-5	SAFETY AND HEALTH CONSIDERATIONS	4-11
4-5.1	Emergency Eyewash and Shower Stations	4-11

CHAPTER 5 FIBERGLASS REINFORCED PLASTIC FABRICATION AND REPAIR FACILITIES

5-1	FUNCTION	5-1
5-2	OPERATIONAL CONSIDERATIONS	5-1
5-3	FLOOR PLAN	5-1
5-4	DESIGN CRITERIA	5-2
5-4.1	Exhaust Air System	5-2
5-4.2	Hood Design	5-2
5-4.3	Ductwork.....	5-6
5-4.4	Fans	5-6
5-4.5	Weather Stack Design and Location	5-6
5-4.6	Air Cleaning Devices.....	5-6
5-4.7	Industrial Vacuum System	5-7
5-5	REPLACEMENT AIR	5-8

5-6	SYSTEM CONTROLS	5-8
5-7	SAFETY AND HEALTH CONSIDERATIONS	5-9

CHAPTER 6 ABRASIVE BLASTING FACILITIES

6-1	FUNCTION	6-1
6-2	OPERATIONAL CONSIDERATIONS	6-1
6-3	DESIGN CRITERIA	6-1
6-3.1	Exhaust Air	6-1
6-3.2	Blasting Cabinets	6-1
6-3.3	Walk-in Blasting Enclosures	6-1
6-3.4	Access Doors and Observation Windows	6-4
6-3.5	Air Cleaning Devices	6-4
6-3.6	Recirculation	6-4
6-3.7	Media Reclamation	6-4
6-3.8	Ductwork	6-4
6-3.9	Fans.....	6-5
6-3.10	Weather Stack Design and Location	6-5
6-3.11	Replacement Air Ventilation Systems	6-5
6-3.12	Heating and Air Conditioning	6-5
6-3.13	System Controls	6-5
6-4	SAFETY AND HEALTH CONSIDERATIONS	6-5
6-4.1	Respiratory Protection	6-5
6-4.2	Air Supply and Air Compressors	6-5
6-4.3	Noise.....	6-5
6-4.5	Hygiene Facilities	6-6

CHAPTER 7 WOOD SHOP FACILITIES

7-1	FUNCTION	7-1
7-2	OPERATIONAL CONSIDERATIONS	7-1
7-3	FLOOR PLAN CRITERIA	7-1
7-4	DESIGN CRITERIA	7-1
7-4.1	Exhaust Air System	7-1
7-4.2	Hood Design	7-2
7-4.3	Floor Sweeps	7-2
7-4.4	Ductwork	7-2
7-4.5	Blast Gates	7-2
7-4.6	Duct Support	7-3
7-4.7	Clean Out Panels	7-3
7-4.8	Exhaust Fans	7-3
7-4.9	Weather Stack Design and Location	7-3
7-4.10	Air Cleaning Devices	7-3
7-4.11	Heating and Air Conditioning	7-3
7-5	SAFETY AND HEALTH CONSIDERATIONS	7-3

CHAPTER 8 BATTERY MAINTENANCE FACILITIES

8-1	FUNCTION	8-1
8-2	OPERATIONAL CONSIDERATIONS	8-1
8-3	DESIGN CRITERIA	8-1
8-3.1	Exhaust System	8-1
8-3.2	Ductwork	8-4
8-3.3	Fans and Motors	8-4
8-3.4	Weather Stack Design and Location	8-4
8-3.5	Air Cleaning Device	8-4
8-3.6	Replacement Air	8-4
8-3.7	System Controls	8-4
8-4	SAFETY AND HEALTH CONSIDERATIONS	8-4

CHAPTER 9 PAINT SPRAY BOOTHS

9-1	FUNCTION	9-1
9-2	OPERATIONAL CONSIDERATIONS	9-1
9-2.1	Painting Equipment Types	9-1
9-3	DESIGN CRITERIA	9-1
9-3.1	Walk-In Spray Paint Booths	9-1
9-3.2	Storage and Mixing Room	9-6
9-3.3	Paint Mix Hoods	9-6
9-4	FANS AND MOTORS	9-6
9-5	REPLACEMENT AIR	9-6
9-5.1	Air Distribution	9-7
9-5.2	Heating and Air Conditioning	9-7
9-6	SYSTEM CONTROLS	9-7
9-7	RESPIRATORY PROTECTION	9-7

CHAPTER 10 AIRCRAFT CORROSION CONTROL HANGARS

10-1	FUNCTION	10-1
10-2	OPERATIONAL CONSIDERATIONS	10-1
10-3	DESIGN CRITERIA	10-1
10-3.1	Exhaust Air System	10-1
10-3.2	Ventilation System Configurations	10-2
10-3.3	Exhaust Filtration System	10-3
10-3.4	Auxiliary Walk-in Paint Spray Room	10-3
10-3.5	Storage and Mixing Room	10-3
10-3.6	Paint Mixing Hood	10-3
10-4	FANS AND MOTORS	10-3
10-5	REPLACEMENT AIR	10-3
10-5.1	Heating and Air Conditioning	10-4
10-6	SYSTEM CONTROLS	10-4
10-7	RESPIRATORY PROTECTION	10-4

GLOSSARY	Glossary-1
-----------------------	------------

ABBREVIATIONS AND ACRONYMS	Glossary-4
---	------------

APPENDIXES

A	-	References	A-1
B	-	Letters Related to Airflow Requirements for Walk-in Spray Paint Booths	B-1
C	-	Letters Related to Airflow Requirements for Aircraft Corrosion Control Hangars	C-1

FIGURES

2-1	Exhaust stack designs	2-4
2-2	Decision tree for replacement air design	2-5
2-3	Plenum design with perforated duct	2-6
2-4	Plenum design without perforated duct	2-7
2-5	Annunciator panel	2-9
3-1	Delagging facility floor plan	3-2
3-2	Exhaust hood for high profile work pieces	3-3
3-3	Exhaust hood for low profile work pieces	3-4
3-4	Sequence of air cleaning devices for asbestos delagging	3-5
3-5	Exhaust and vacuum system schematic diagram	3-7
4-1	Layout for MK-46 fuel/defuel and afterbody breakdown room	4-2
4-2	Series of hoods in MK-46 shop	4-2
4-3	MK-46 standup backdraft hood	4-3
4-4	MK-46 workbench hood	4-4
4-5	MK-46 parts washer hood	4-4
4-6	Typical MK-48 ventilated space layout	4-5
4-7	MK-48 afterbody teardown hood	4-6
4-8	MK-48 workbench hood	4-7
4-9	MK-48 parts washer hood	4-7
4-10	MK-48 hood sequence afterbody teardown and accessories rooms	4-8
4-11	MK-48 refueling hood	4-9
4-12	Vertical distribution method	4-10
4-13	Horizontal distribution method	4-10
5-1	Floor plan for FRP facility	5-2
5-2	Workbench hood	5-4
5-3	Floor exhaust	5-4
5-4	Spray up booth	5-5
5-5	Ventilated sink	5-5
5-6	Exhaust system schematic	5-7
6-1	Downdraft blast enclosure	6-2
6-2	Crossdraft blast enclosure	6-3
7-1	Floor sweep	7-2

8-1	Ventilation system for battery maintenance facilities	8-2
9-1	Walk-in downdraft paint booth	9-3
9-2	Drive through crossdraft paint booth with mechanical replacement air.....	9-4
9-3	Drive through crossdraft paint booth with no mechanical replacement air.....	9-5
9-4	Paint mixing hood and work bench.....	9-6
10-1	Crossdraft corrosion control hangar	10-2
10-2	Hangar door and exhaust plenum details	10-3

TABLES

3-1	Minimum Volumes and Vacuum Hose Size for Asbestos Operations	3-6
5-1	Recommended Hoods, Capture Velocity and Air Pollution Device	5-3

CHAPTER 1

INTRODUCTION

1-1 **SCOPE.** This Unified Facilities Criteria (UFC) provides criteria for the design of ventilation systems that control contaminants generated from industrial processes.

1-2 **PURPOSE OF CRITERIA.** Criteria are developed to define requirements during the design of industrial ventilation systems. Chapter 2 provides general criteria and Chapters 3 through 10 provide criteria for specific processes. Use the general criteria presented in Chapter 2 along with the applicable specific criteria presented in Chapters 3 through 10 to design the ventilation system. For all other ventilation applications, use the criteria in Chapter 2.

Criteria contained in this UFC should be interpreted as the minimum required and should be improved where current technology or situation warrants. Users of this UFC are advised to consult the most current edition of the standards.

This UFC does not incorporate individual state and local environmental requirements. It is the sole responsibility of the cognizant design personnel to design an industrial ventilation system that complies with state and local environmental requirements.

1-3 **SPECIFIC PROCESSES.** The specific processes addressed in this handbook are asbestos delagging, torpedo refurbishing (Otto Fuel II), fiberglass reinforced plastic fabrication and repair, abrasive blasting, woodworking, battery maintenance, paint spray booths, and aircraft corrosion control hangers.

CHAPTER 2

GENERAL REQUIREMENTS

2-1 **GENERAL CRITERIA.** Installing engineering controls is the preferred method of controlling hazardous processes as specified in 29 CFR 1910.1000(e), *Air Contaminants* and OPNAVINST 5100.23, *Navy Occupational Safety and Health Program Manual*. Properly designed industrial ventilation systems are the most common form of engineering controls.

2-2 **COORDINATION.** Form a project design team to direct the design of industrial ventilation projects. Include in the design team representatives from:

- Effected industrial shop.
- Public works.
- Health and safety office.
- Cognizant Regional Engineering Office (REO) (for example: Navy Engineering Field Division, Army Corps of Engineers Division, and Air Force major command engineering office). The REO representative establishes a design team and acts as the team leader in all cases, except when the cognizant REO grants a variance.
- Industrial hygiene and safety offices.

NOTE U.S. NAVY: BUMED or activity IH. Use Naval Environmental Health Center as a back-up.

- System command program manager (where applicable).
- System safety engineer.
- Environmental manager.

2-3 **DESIGN PROCEDURE.** Refer to the ACGIH IV Manual, *Industrial Ventilation; A Manual of Recommended Practice*, Chapter 5, "Exhaust System Design Procedure," for system design calculations. Design all industrial ventilation systems in accordance with paragraphs 2-3.1 through 2-3.8.

2-3.1 **Step 1.** Identify all significant contaminant sources that require ventilation control. Request the local industrial hygiene office to provide a source characterization with area diagrams of the contaminant sources, and employee work areas. Also,

consider how the system being designed might affect the performance of any existing processes, industrial ventilation systems or HVAC systems.

2-3.2 **Step 2.** Consider how the facility is to be used or expanded in the future. It may be possible to initially specify fans that are capable of handling future needs at minimal increased cost.

2-3.3 **Step 3.** Select or design the exhaust hood that best suits the work piece or operation. Design the exhaust hood to enclose the work piece or operation as much as possible. This will reduce the ventilation rates required to provide contaminant control. This UFC provides optimum exhaust hood designs for many of the operations covered.

2-3.4 **Step 4.** Determine the capture velocity required to control generated contaminants. Capture velocities in this UFC are specified assuming there are no cross drafts or turbulence that adversely affects the capture efficiency. Reduce potential for cross drafts or turbulence near a given exhaust hood by properly locating and designing the hood with baffles, and also by designing the replacement air system to complement the exhaust system.

2-3.5 **Step 5.** Determine the exhaust volumetric flow, in cubic meters per second (m^3/s) [cubic feet per minute (cfm)], required to maintain the capture velocity determined in paragraph 2-3.4.

2-3.6 **Step 6.** Create a line drawing of the proposed system. Include plan and elevation dimensions, fan location and air cleaning device location. Identify each hood, branch duct and main duct sections.

2-3.7 **Step 7.** Size ductwork using the balance by design or the blast gate method. Maintain the required minimum transport velocity throughout the system.

2-3.8 **Step 8.** Determine requirements for replacement air. Based on the process, determine if the room should be under slightly negative, neutral or slightly positive pressure with respect to the surrounding area. The surrounding area can be either outside the building envelope or an adjacent room or hallway. Determine if tempered replacement air is needed.

2-4 **DESIGN CRITERIA.** Several design criteria are common to all industrial ventilation systems; use the ACGIH IV Manual for primary guidance. See paragraphs 2-4.1 through 2-4.5 for additional guidance. Chapters 3 through 10 provide design guidance for specific types of facilities.

2-4.1 **Ductwork.** In addition to the recommendations of the ACGIH IV Manual, consider the following when designing a ventilation system.

- a. Specify duct gage, reinforcement schedule and hanger design and spacing, in accordance with SMACNA RIDCS, *Round Industrial Duct Construction Standards* for round duct and SMACNA RTIDCS, *Rectangular Duct Construction Standards* for rectangular duct.
- b. Install clean-out doors in ductwork that conveys particulate material such as wood dust or blasting grit. Mount clean-out doors on top half of horizontal runs near elbows, junctions, and vertical runs.

2-4.2 Fans

2-4.2.1 **Selection.** Except where specified below, fan selection criteria for replacement air fans and exhaust air fans are identical.

- a. Select exhaust system industrial fans that meet design pressure and volume flow rate requirements and have the AMCA-certified performance seal. The design pressure requirement must account for any system effects caused by non-uniform airflow into or out of the fan. See AMCA 201, *Fans and Systems* for more information on system effects. Specify a fan class that is appropriate for the design operating point. Do not select fans with forward curved blades.
- b. When selecting fan capacity, consider if the process room pressure will be positive, negative or neutral with respect to the external areas. Select a fan that will provide the necessary volumetric flow rate to maintain the desired process room pressure. Ensure that all sources of exhaust air are considered when selecting fan capacity. See paragraph 2-4.5 for more details.
- c. Specify fan shafts that have a uniform diameter along the entire length. Use bearings that are rated with an average life of 200,000 hours.
- d. Select only energy efficient motors. Select the motor to handle cold startup amperage for nonstandard air processes.
- e. Specify vibration-isolating couplings at the fan inlet and outlet. Mount all fans on vibration isolating bases.
- f. If the planner's forecasts change in the processes to occur within the next couple of years, which would require an increase in the amount of replacement or exhaust air, then consider purchasing a larger capacity fan and oversized wiring.

2-4.2.2 **Location.** Locate the exhaust fan after the air pollution control equipment to protect fan blades from contaminated air-stream. Provide access for maintenance to all fans, including ladders and guardrails where necessary. Refer to NFPA 70, *National*

Electrical Code for motor controller and disconnect location requirements. In all cases, install exhaust fans outside the building that they serve. Installing the fan outside the building envelope will isolate the working space from contaminants during fan maintenance, minimize noise inside the building, and ensure that ductwork within the building envelope is under negative pressure.

2-4.3 Exhaust Stacks

2-4.3.1 **Design Considerations.** Refer to the ACGIH IV Manual for exhaust stack design criteria. The best designs are cylindrical, vertical discharge stacks as shown in Figure 2-1. The best protection from rain, when the ventilation system is not running, is the “offset stack” design C, as shown in Figure 2-1. Water may still enter the system with straight stack design A. Provide a means to drain water from the fan housing.

Figure 2-1. Exhaust stack designs.

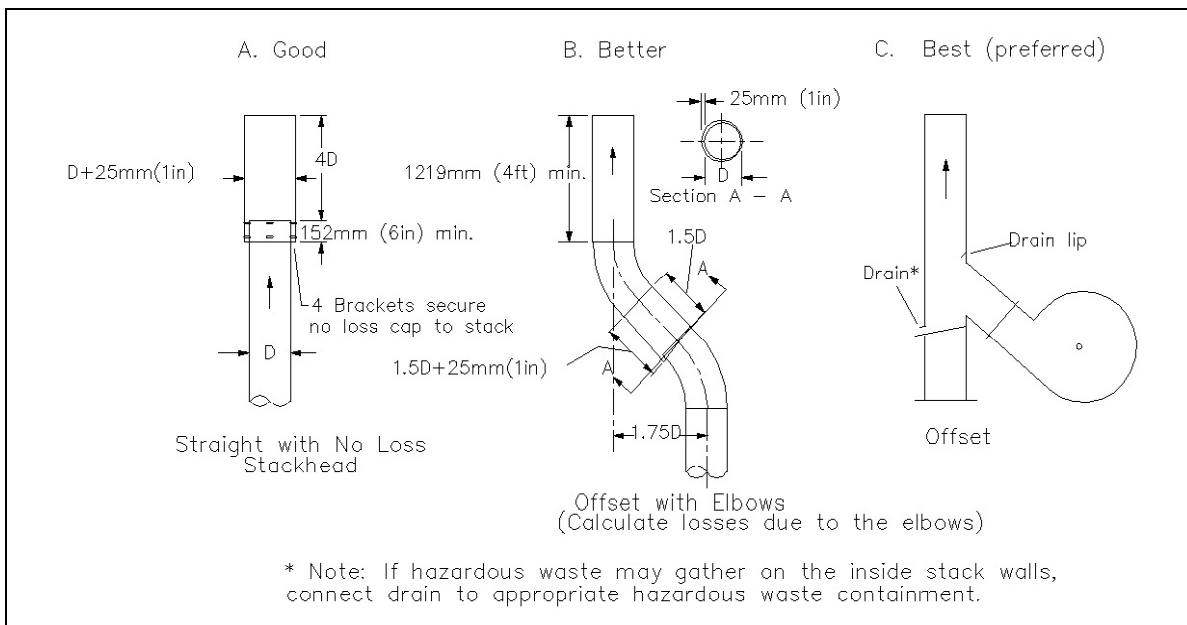

2-4.3.2 **Location and Structural Considerations.** Refer to ASHRAE Handbook, *Fundamentals* for information on airflow around buildings. Do not select stack locations based on prevailing winds. A stack must provide effluent dispersion under all wind conditions. Refer to UFC 1-200-01, *Design: General Requirements* for exhaust stack structural design considerations. Some structural considerations are wind load, lightning protection, and stack support. Refer to MIL-HDBK-1004/6, *Lightning (and Cathodic) Protection* and SMACNA GSSDC, *Guide for Steel Stack Design and Construction* for additional information.

2-4.4 **Air Pollution Control Equipment.** Requirements for air pollution equipment vary by process and geographical region in the United States. Contact the

local activity environmental manager to determine the pollution control requirements for the process.

2-4.5 **Replacement Air.** Replacement air is as important as exhaust air in controlling industrial process contaminants. Properly designed replacement air will (1) ensure that exhaust hoods have enough air to operate properly, (2) help to eliminate cross-drafts through window and doors, (3) ensure proper operation of natural draft stacks, (4) eliminate cold drafts on workers, and (5) eliminate excessive differential pressure on doors and adjoining spaces. The method of distributing replacement air and the quantity of replacement air are critical with respect to exhaust air. Design the replacement air system in accordance with the decision tree shown in Figure 2-2.

Figure 2-2. Decision tree for replacement air design.

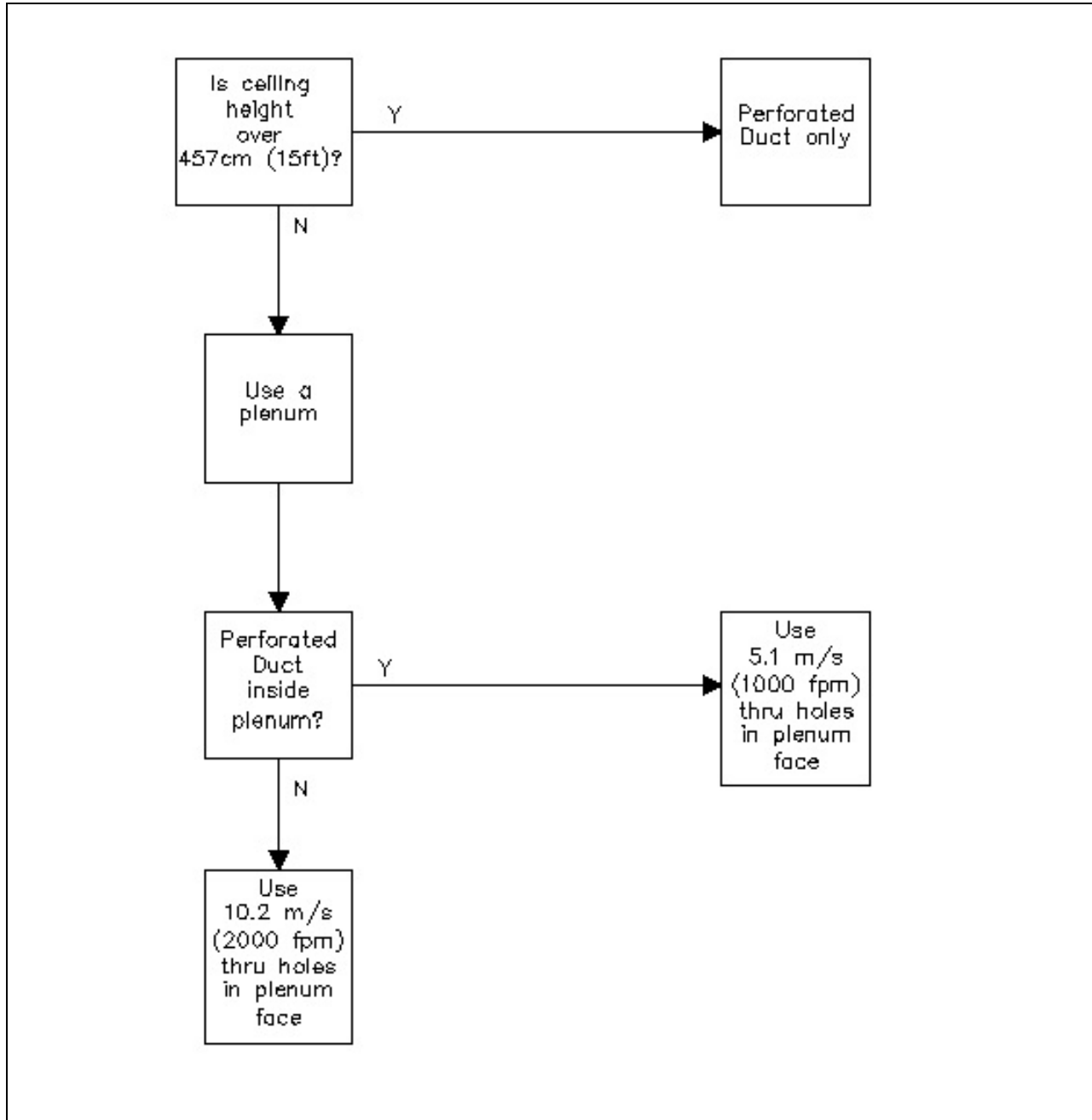

2-4.5.1 **Space Pressure Modulation.** Control the ventilated space pressure by modulating the quantity of replacement air. Use a variable frequency drive (VFD) motor to control the fan speed (see MIL-HDBK-1003/3, *Heating, Ventilating, Air Conditioning, and Dehumidifying Systems* for information of VFD motors). Using barometric dampers to control replacement air quantity is inefficient and unreliable. Sensor controlled transfer grilles are acceptable provided there will not be a problem with contaminated migration.

2-4.5.2 **Plenum Design.** Use perforated plate to cover as much of the ceiling (or wall opposite the exhaust hood(s)) as practical. The diameter of the perforation should be between 6.3 mm and 9.5 mm (1/4 in and 3/8 in). Perforated plenums work best when ceiling height is less than 4.58 m (15 ft). Use either of the following two choices for replacement air plenum design:

- a. Design for 5.1 m/s (1,000 fpm) replacement air velocity through the open area of the perforated plate if perforated duct is used inside the plenum as shown in Figure 2-3.
- b. Design for 10.2 m/s (2,000 fpm) replacement air velocity through the open area of the perforated plate if the plenum is served with ducts using diffusers, grills or registers as shown in Figure 2-4.

Figure 2-3. Plenum design with perforated duct.

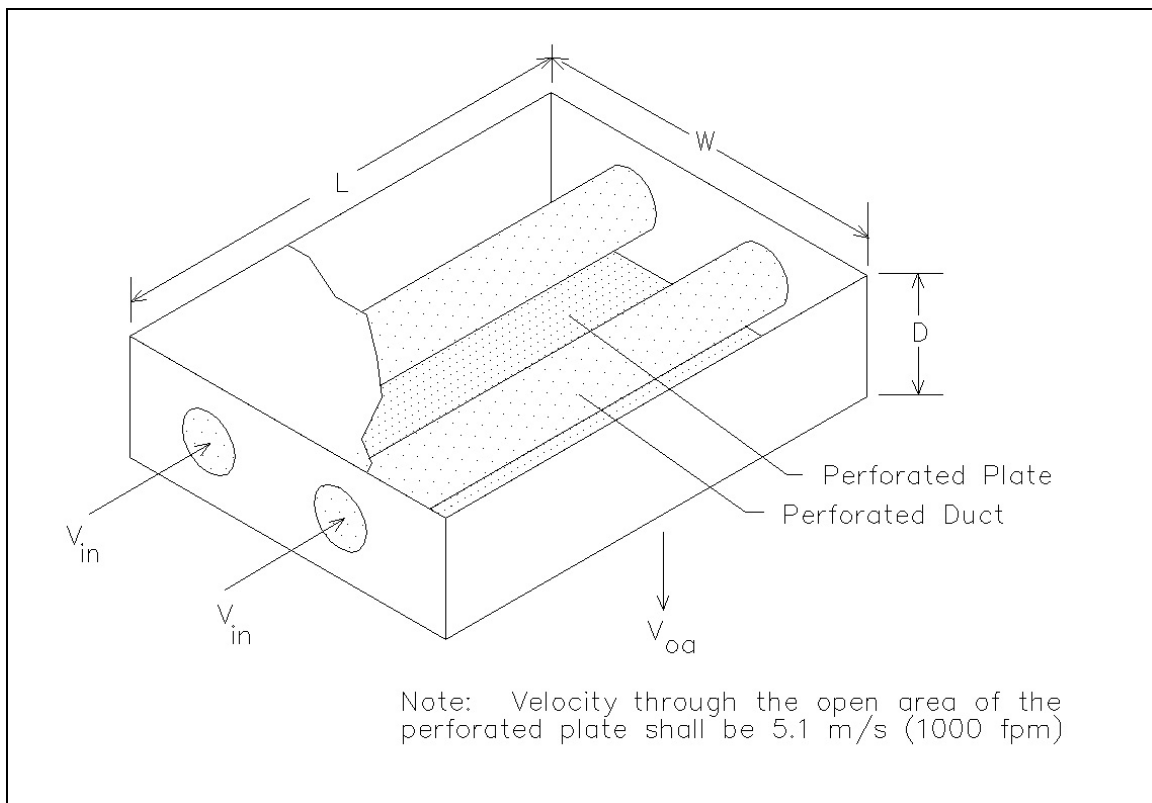
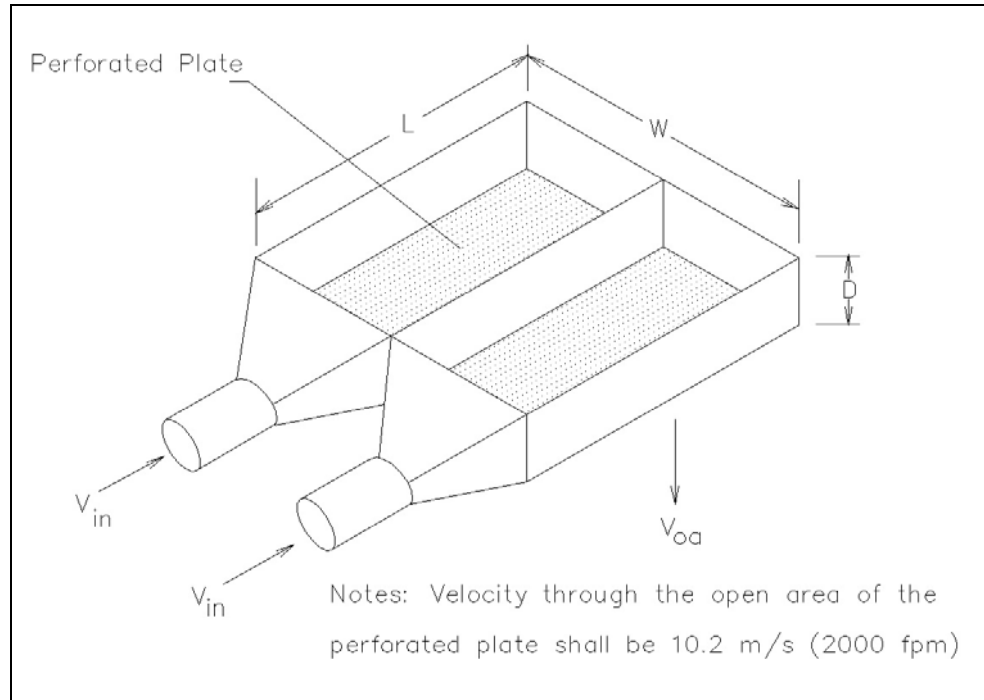

Figure 2-4. Plenum design without perforated duct.



2-4.5.3 **Perforated Duct Design.** Use perforated duct to evenly distribute the flow of replacement air inside a plenum or use alone when ceiling height is greater than 4.58 m (15 ft). Manufacturers provide several different types and sizes of perforated duct. Use recommendations from the manufacturer for duct design. The manufacturer will not only recommend the size, shape, and type of the required perforated duct, but also the location of the orifices and reducers to distribute the air properly.

2-5 **CONTROLS.** Provide industrial ventilation system controls and associated alarms to ensure contaminant control, space specific balance and conditioning, a safe and healthy work environment, and system malfunction notification.

2-5.1 **Gauges and Sensors.** Specify gauges and sensors to provide continuous monitoring of system performance. The minimum requirements are:

2-5.1.1 Differential pressure sensors, with gauge readouts, across each replacement air filter section. Set points on the gauge to trigger an alarm when the pressure drops or gains across the filter exceed the manufacturer's recommended value. A pressure drop occurs when there is a blow through a filter and a pressure gain occurs when the filter gets loaded.

2-5.1.2 Operating light on replacement air system fan motor.

2-5.1.3 Static pressure sensor at the outlet of the replacement air fan with a gauge readout. Set the points on the gauge to trigger an alarm when the pressure is lower than the recommended range (as determined by baseline testing).

2-5.1.4 Hood static pressure sensor, for critical processes or process where extremely toxic substances are used, with a gauge mounted in a conspicuous place near the hood. Set the points on the gauge to trigger an alarm when the static pressure is lower or higher than the recommended range (as determined by baseline testing). Do not use the type of inline flow sensor, which measures the pressure drop across an orifice plate. Use only a static pressure tap and differential pressure gauge.

2-5.1.5 Differential pressure sensor across each exhaust air-cleaning device with gauge readout. Set points on the gauge to trigger an alarm when the pressure drop across the device exceeds the manufacturer's recommended value.

2-5.1.6 Static pressure sensor at the exhaust fan inlet with gauge readout. Set the points on the gauge to trigger an alarm when the pressure is lower than the recommended range (as determined by baseline testing).

2-5.1.7 Operating light on exhaust air system motor. When a sensor indicates a malfunction, trigger an alarm that is both audible and visible in the shop space.

2-5.1.8 Operating ranges on all gauges clearly marked. Locate gauges on an annunciator panel (except hood static pressure gauges). Provide a 3-way valve at each gauge connection for cleanout and calibration; see Figure 2-5.

2-5.1.9 Place room differential pressure sensors away from doors, windows, and replacement air discharge.

2-5.2 **Interlocks.** Provide an interlocked on-off switch so that the replacement air and exhaust air systems operate simultaneously. When there are multiple fans, clearly label which exhaust fan is interlocked with which supply fan.

2-5.3 **Annunciator Panel.** Provide an annunciator panel to continuously monitor ventilation system performance. Locate the panel so it is accessible to shop personnel. The panel must include, but is not limited to, all gauges (except hood static pressure gauges) described in paragraph 2-5.1. Mount fan motor operating lights and interlocked ON/OFF switch on the panel. The interlocked switches must clearly show which exhaust and supply fans are interlocked, where multiple fans are used. The panel should indicate what action to take when operation falls outside the prescribed ranges. For example, "examine/replace filter on R.A. unit when this gauge reads outside indicated range."

Figure 2-5. Annunciator Panel.

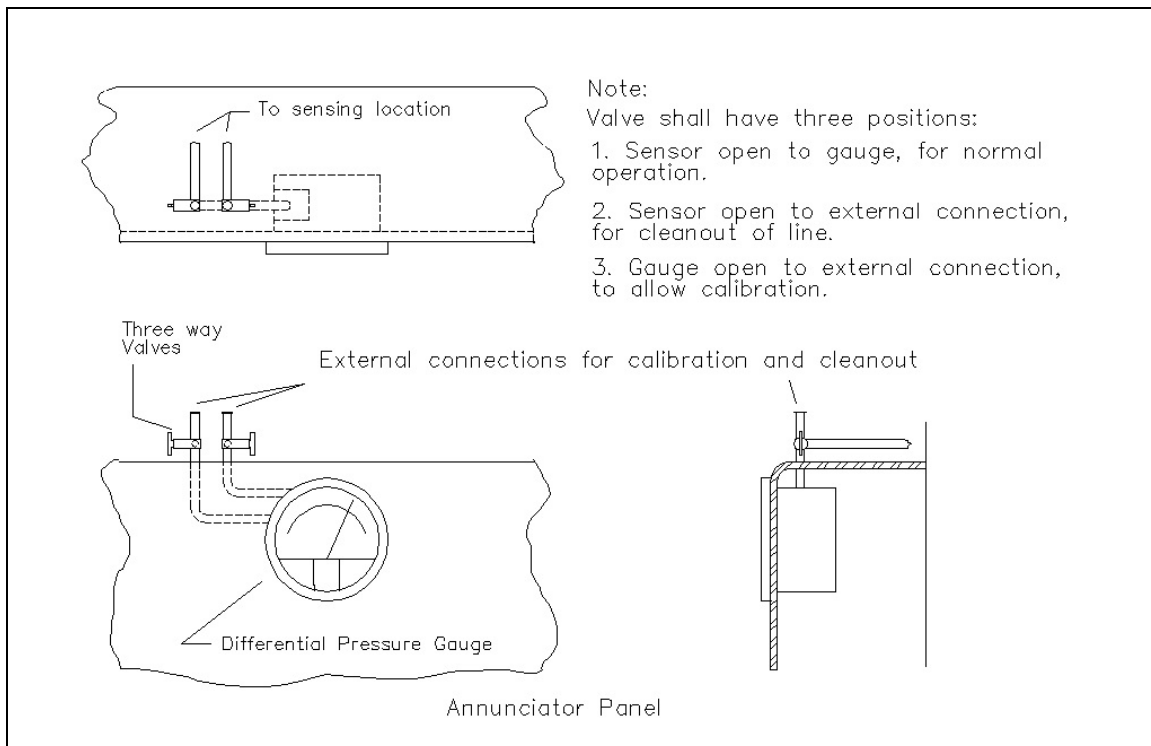

2-6 OPERATIONAL CONSIDERATIONS

2-6.1 **Provision for System Testing.** Provide access to the fan and motor to measure voltage, amperage, and fan speed. Specify that all testing will be done in accordance with the ACGIH IV Manual, Chapter 9, "Monitoring and Testing of Ventilation Systems."

2-6.2 **Energy Conservation.** Incorporate applicable energy conservation measures in the design of all industrial ventilation systems. Criteria herein minimize volume flow rates through appropriate designs. Evaluate life cycle costs for heat recovery systems and specify when appropriate. Refer to ASHRAE Handbook, *HVAC Systems and Equipment* and MIL-HDBK-1003/3 for details.

2-6.3 **Recirculation.** Industrial ventilation systems use a large quantity of air. Exhaust air recirculation is discouraged for most Naval industrial processes and prohibited by OPNAVINST 5100.23 for processes generating lead and asbestos. Follow the re-circulated air guidelines set forth in UFC 3-600-01, *Design: Fire Protection Engineering for Facilities* and NFPA 654, *Standard for the Prevention of Fire and Dust Explosions from the Manufacturing, Processing, and Handling of Combustible Particulate Solids* for fire protection; the ACGIH IV Manual and ANSI Z9.7, *Recirculation of Air from Industrial Process Exhaust Systems* for health protection, and the applicable OSHA standards when recirculation is included in the design.

2-6.4 **Maintenance.** Require the contractor provide an operation and maintenance manual for the system and also provide hands-on training for maintenance and shop personnel.

2-7 SAFETY AND HEALTH CONSIDERATIONS

2-7.1 **Posting.** For those systems where the replacement air is critical to the proper operation of the system, consider posting the following sign at each entrance to the ventilated space:

KEEP DOOR CLOSED
THIS DOOR MUST BE CLOSED FOR
EFFECTIVE CONTROL OF CONTAMINANTS

2-7.2 **Noise.** Use engineering controls as the primary means of protecting personnel from hazardous noise. It is cheaper to eliminate potential noise problems during the design or procurement stages, than it is to retrofit or modify after installation. Determine the acoustic environment of any kind of activity in advance, both to fulfill the design goals and prevent the need for corrections at a later stage.

2-7.2.1 **Criteria.** Specify the lowest noise emission level that is technologically and economically feasible. Each DOD service branch has a permissible noise level specified in its safety and health manual. It is not adequate to specify that individual pieces of equipment do not produce noise levels in excess of that permissible level. Determine the sound power levels for each piece of equipment. Use this information to predict the acoustic characteristics of the workspace and the resulting ambient noise level. Specify the appropriate noise control method if the total predicted ambient noise level is in excess of the requirements in the applicable safety and health manual. For additional information on noise control refer to UFC 3-450-01, *Design: Noise and Vibration Control*; DHEW 79-117, *NIOSH Industrial Noise Control Manual*; OSHA Pub 3048, *Noise Control, A Guide for Workers and Employees*; and NAVFAC P-970, *Protection Planning in the Noise Environment*.

2-7.3 **Respiratory Protection.** 29 CFR 1910.134(d), *Respiratory Protection* specifies requirements for respiratory protection. Consult with an industrial hygienist or occupational health specialist to determine the appropriate type of respiratory protection required for each process.

2-7.3.1 **Breathing Air.** Breathing air for supplied air respirators must meet grade D standards as required by 29 CFR 1910.134(d) and defined in Compressed Gas Association Specification for Air G-7.1. Breathing air couplings must not be compatible with outlets for non-respirable worksite air or other gas systems. Consider providing

multiple connection ports for airline respirator hoses to allow worker mobility. Consider installing a panel to permit the IH to test air quality on a routine basis.

NOTE for USAF: The test panel is required for quarterly testing.

2-7.3.2 **Air Compressors.** Oil lubricated breathing air compressors require a high temperature or carbon monoxide alarm or both. If only a high temperature alarm is used, the air supply must be monitored to ensure the breathing air does not exceed 10 parts per million (ppm) carbon monoxide. Compressors that are not oil lubricated must still have the carbon monoxide level monitored to ensure it is below 10 ppm. Compressors used to supply breathing air must be constructed and situated to prevent entry of contaminated air into the air supply system. The breathing air compressor must minimize moisture content so that the dew point is 5.56 °C (10 °F) below the ambient temperature. The breathing air system must have suitable inline air-purifying sorbent beds and filters. Sorbent beds and filter will have to be maintained per manufacturer's instructions.

2-7.4 **Emergency Showers and Eyewash Stations.** Provide where required. Design in accordance with UFC 3-420-01, *Design: Plumbing Systems*.

2-7.5 **Hygiene Facilities.** These facilities are adjacent to or nearby the operation when employees are exposed to certain stressors such as asbestos, cadmium, lead, etc. The facilities may be as simple as a hand washing station or as complicated as multiple clean/dirty rooms in an asbestos delagging facility. Consult with the local industrial hygiene department to determine the extent of and location for these facilities.

2-8 **COMMISSIONING.** This process begins before the conceptual design is complete. It is a strategy that documents the occupants' needs, verifies progress and contract compliance and continues throughout the design, build and acceptance process. DOD projects and construction offices have long used parts of the commissioning process for military construction (MILCON) and some smaller projects. To ensure that issues specific to ventilation are not overlooked, consider using ASHRAE Guideline 1, *The HVAC Commissioning Process*.

CHAPTER 3

ASBESTOS DELAGGING FACILITIES

3-1 **FUNCTION.** An asbestos delagging facility provides a complete workshop to remove asbestos insulation from piping and mechanical equipment during ship repair. The ventilation system design discussed in this section is for activities with extensive asbestos removal operations. The design includes: shop and equipment space, clean and dirty locker rooms for men and women, and administrative space to support the coordination and monitoring of facility operation.

3-2 **OPERATIONAL CONSIDERATIONS**

3-2.1 **Airborne Contamination.** When asbestos insulation is delagged, the asbestos fibers are dispersed into the air, creating a health hazard. 29 CFR 1910.1001, *Asbestos, General Industry* and 29 CFR 1915.1001, *Asbestos, Shipyards* dictate protective measures for workers in these facilities, including respirator protection and impermeable outerwear. The regulations also prescribe wetting the asbestos material with amended water (water containing a surfactant), if practicable, to reduce the potential for asbestos fibers to become airborne.

3-2.2 **Heat Stress.** The physical nature of the work and impermeable outer garments worn by the workers creates heat stress conditions. Provide supplied air respirators with vortex tubes as specified in EPA-560-OPTS-86-001, *A Guide to Respiratory Protection for the Asbestos Abatement Industry*. Consider cooling the replacement air when supplied air respirators are not available. Consider using "micro climate cooling" or "cool suits," mechanically cooled garments, for individual workers.

3-2.3 **Employee Workflow.** Workers enter the clean locker rooms through the administrative area. They put on protective outerwear and proceed to the shop area. After performing delagging, workers vacuum their protective outerwear and dispose of them in containers provided in the decontamination area. They enter the dirty locker rooms and remove the remainder of their work garments. Workers then proceed to the clean locker rooms via the showers, which act as a barrier to the migration of asbestos fibers.

3-3 **TYPICAL FLOOR PLANS.** Design floor plans to meet the requirements of 29 CFR 1910.1001 and 29 CFR 1915.1001 and paragraph 3-2.3. Figure 3-1 shows a sample delagging facility floor plan.

Figure 3-1. Delagging facility floor plan.

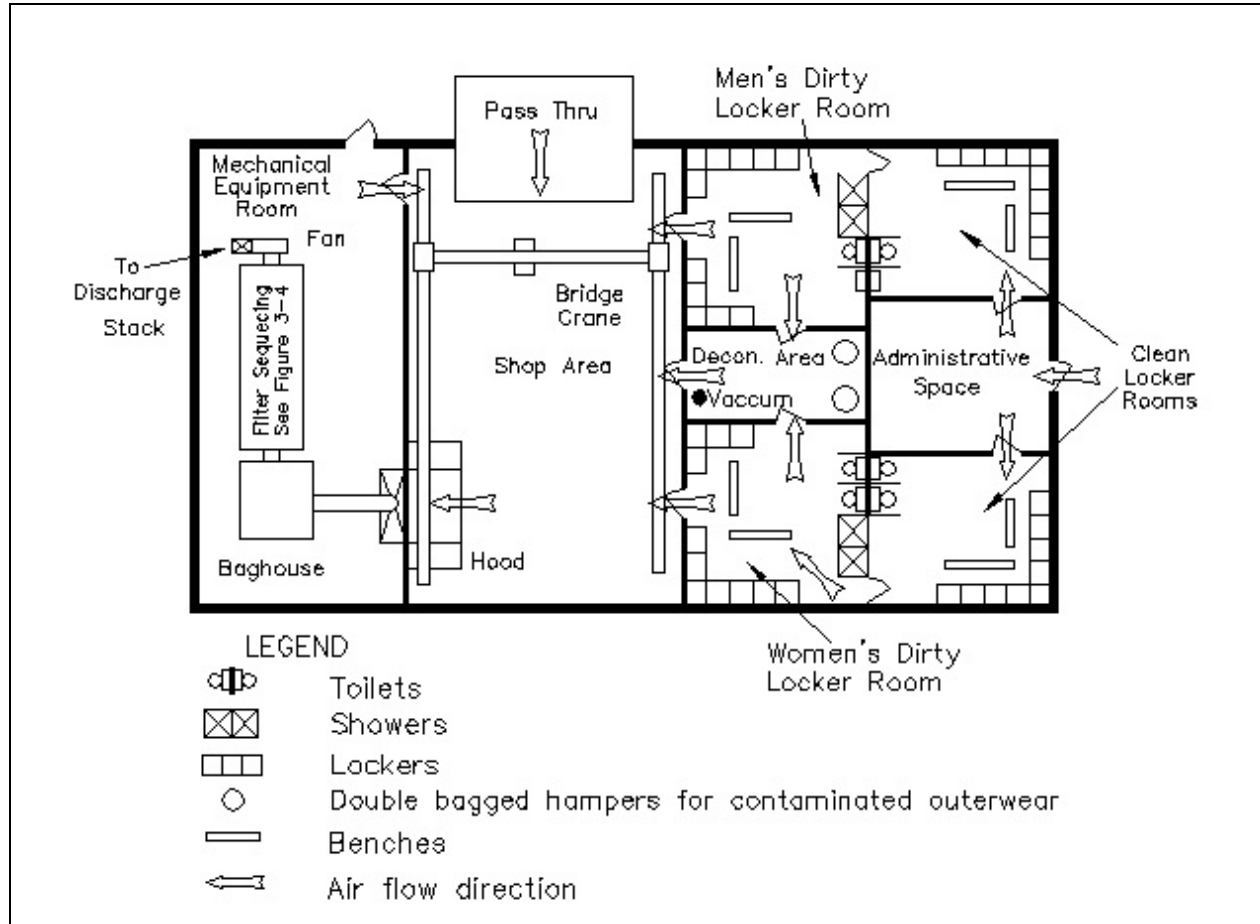

3-4 **DESIGN CRITERIA.** Design the facility using general technical requirements in Chapter 2 of this UFC and the specific requirements in this Chapter.

3-5 **EXHAUST AIR.** Design the exhaust air system to generate a minimum capture velocity of 0.762 m/s (150 fpm) to capture all the contaminants at the source.

3-5.1 **Hood Design.** Design asbestos delagging hood to enclose the work piece as much as possible. Do not use small portable hoods with flexible ductwork because they do not provide consistent capture.

3-5.1.1 **Typical Hood Design for High Profile Work Pieces.** Figure 3-2 shows a hood design consisting of a workbench with a central, circular area. Mount the circular area on sealed bearings to allow easy turning of heavy work pieces. This design is best for high profile work pieces (for example, boilers, pumps). The hood captures contaminants through the slots into an exhaust plenum. Design each hood with:

- a. Two cleanout doors on the front and two doors on the sides of the hood for easy access to asbestos debris. Provide two small cutouts in the outer

corners of the workbench to place large pieces of lagging in double bagged containment.

- b. The top baffle swings up to allow access to overhead cranes.

Figure 3-2. Exhaust hood for high profile work pieces.

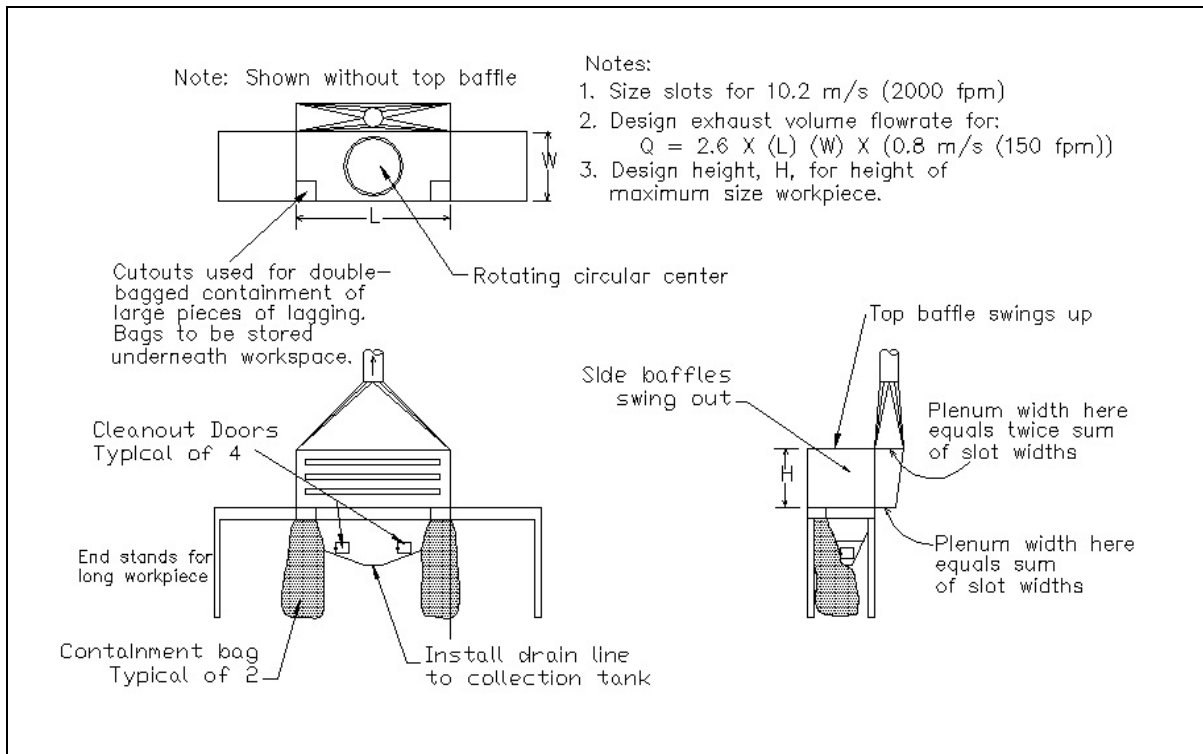

3-5.1.2 Typical Hood Design for Low Profile Work pieces. Figure 3-3 shows a hood design consisting of a workbench with a grating strong enough to support the heaviest expected work piece. This is a downdraft hood that draws small pieces of lagging through the grating. The perforated plate below the grating creates even airflow over the grating. This design is best for low profile work pieces such as piping. Design each hood with stands and swinging baffles on each end to accommodate long work pieces (e.g., pipes).

3-5.3 Ductwork. Size the exhaust ductwork to provide a minimum transport velocity of 25.4 m/s (5,000 fpm). The high velocity is necessary because the practice of wetting the fibers makes them heavier and more difficult to transport. See paragraph 2-4.1 for general duct considerations.

Figure 3-3. Exhaust hood for low profile work pieces.

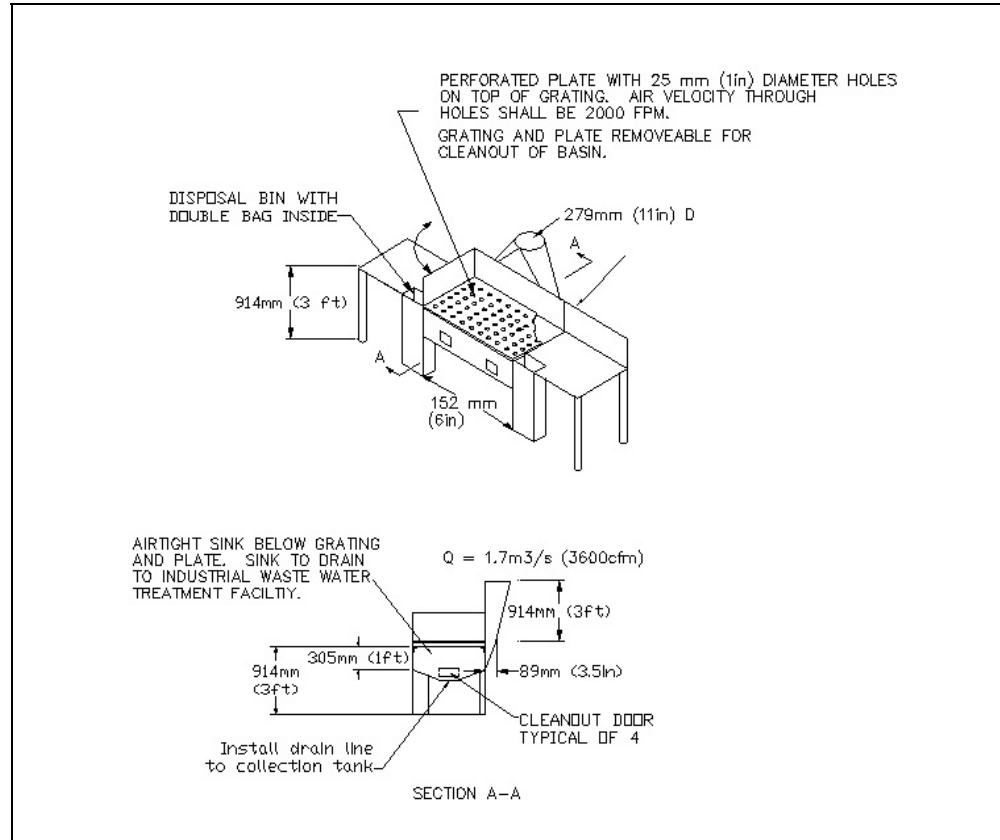

3-5.4 **Fans.** See paragraph 2-4.2 for general fan considerations.

3-5.5 **Weather Stack Design and Location.** See paragraph 2-4.3.

3-5.6 **Air Cleaning Devices.** A delagging facility requires multistage filtering, which consists of a fabric filter collector, prefilters, a mist eliminator, and high efficiency particulate air (HEPA) filters. Prefilters extend the life of the HEPA filters. Use "bag in, bag out" styles of HEPA filters, which allow for safe replacement of the filter element without exposure to asbestos. A mist eliminator before the HEPA filter protects it from the moisture generated during asbestos removal.

a. Have all collectors deliver the collected asbestos to a common pickup point to minimize the risk of exposure. Provide a double acting valve at each collector hopper throat, in accordance with the ACGIH IV Manual, Chapter 4.

b. Use a single chamber, shaker type collector to minimize the number of collection points.

3-5.6.1 **Filter Efficiency.** The fabric filter collector requires a minimum efficiency reporting value (MERV) of not less than 15 in accordance with ASHRAE 52.2, *Method*

of Testing General Ventilation Air Cleaning Devices for Removal Efficiency by Particle Size.

3-5.6.2 **Sequencing.** Figure 3-4 illustrates the required sequence of air cleaning devices.

Figure 3-4. Sequence of air cleaning devices for asbestos delagging.

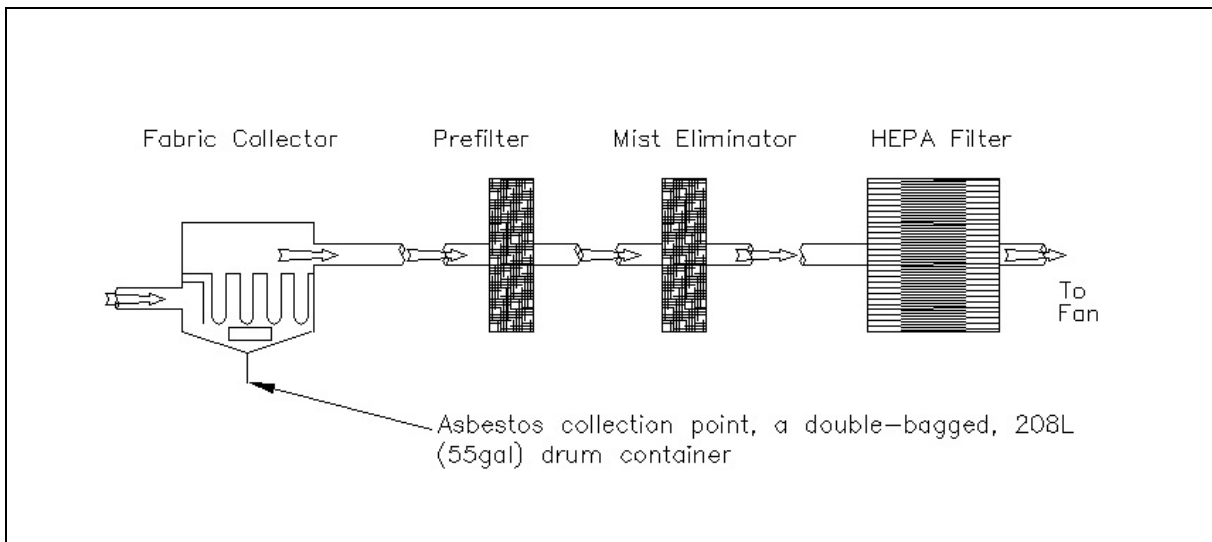

3-5.7 **Industrial Vacuum System.** Provide a low volume, high velocity (LVHV) central vacuum system at delagging shops to exhaust fibers and dust from power tools (e.g., grinders and saws) when they are used, as specified in 29 CFR 1910.1001.

3-5.7.1 Design a central vacuum cleaning system, which consists of a motor driven exhauster interconnected with bag type separators.

3-5.7.2 Connect the separator to rigid tubing, which extends throughout the plant. Terminate the rigid tubing with inlet valves at the various workstations. Provide flexible hose connections to allow workers to do shop cleanup and to decontaminate their protective outerwear.

3-5.7.3 Use local exhaust hoods and high velocity exhaust takeoffs for each hand tool. Table 3-1 and the ACGIH IV Manual provide examples of tools and exhaust system for specific operations.

3-5.7.4 Ensure proper capture velocity is produced at each local exhaust hood. Design vacuum systems to reach within 12.7 mm (1/2 inch) of the contaminant source.

3-5.7.5 Design the pickup air-stream to have a velocity of two to three times the generation velocity for particle sizes from 20 to 30 micrometers (20 to 30 micron.) Design for an additional velocity of: (1) four to five times the generation velocity to pull the particles up through 300 U.S. standard mesh, or (2) six to eight times the generation velocity to pull the particles up through a 20 U.S. standard mesh.

TABLE 3-1. Minimum Volumes and Vacuum Hose Size for Asbestos Operations

Hand Tool	Flow rate m ³ /s (cfm)	Hose Size mm (in.)
Pneumatic chisel	0.06 (125)	38 (1.5)
Radial wheel grinder	0.07 (150)	38 (1.5)
Cone wheel grinder, 2 inch	0.07 (150)	38 (1.5)
Cup stone grinder, 4 inch	0.09 (200)	51 (2.0)
Cup type brush, 6 inch	0.12 (250)	51 (2.0)
Radial wire brush, 6 inch	0.08 (175)	38 (1.5)
Hand wire brush, 3 x 7 inches	0.06 (125)	38 (1.5)
Rip out knife	0.08 (175)	38 (1.5)
Rip out cast cutter	0.07 (150)	38 (1.5)
Saber saw	0.07 (150)	38 (1.5)
Saw abrasive, 3 inch	0.07 (150)	38 (1.5)
General vacuum	0.09 (200)	51 (2.0)

Adapted from: Hoffman Air and Filtration Systems, "Design of Industrial Vacuum Cleaning Systems and High Velocity, Low Volume Dust Control."

3-5.7.6 Design the air volume for no less than two parts of air to one part of asbestos to be captured by weight.

3-5.7.7 Design the vacuum hose length less than 7.6 m (25 ft). Locate inlet valves 9 to 10.7 meters (30 to 35 feet) apart when a 7.6-m (25-ft) length of hose is used. Locate tool vacuum hose connection on the ends of the workbench underneath the stands. Size the hose based on: (1) air volume per hose, (2) number of hoses to be used simultaneously, and (3) air velocity required to convey the material to the separators.

3-5.7.8 Use single-ply, lightweight thermoplastic or polyvinyl chloride (PVC) flexible hose, but limit the usage whenever possible.

3-5.7.9 Use a multistage centrifugal blower for the vacuum system. Size the blower for: (1) total system pressure loss associated with the total number of hoses to be used simultaneously, and (2) maximum exhaust flow rate entering the inlet of the blower.

3-5.7.10 Feed the blower directly into the bag house used by the industrial exhaust system (see Figure 3-5) to minimize the number of asbestos collection points.

Figure 3-5. Exhaust and vacuum system schematic diagram

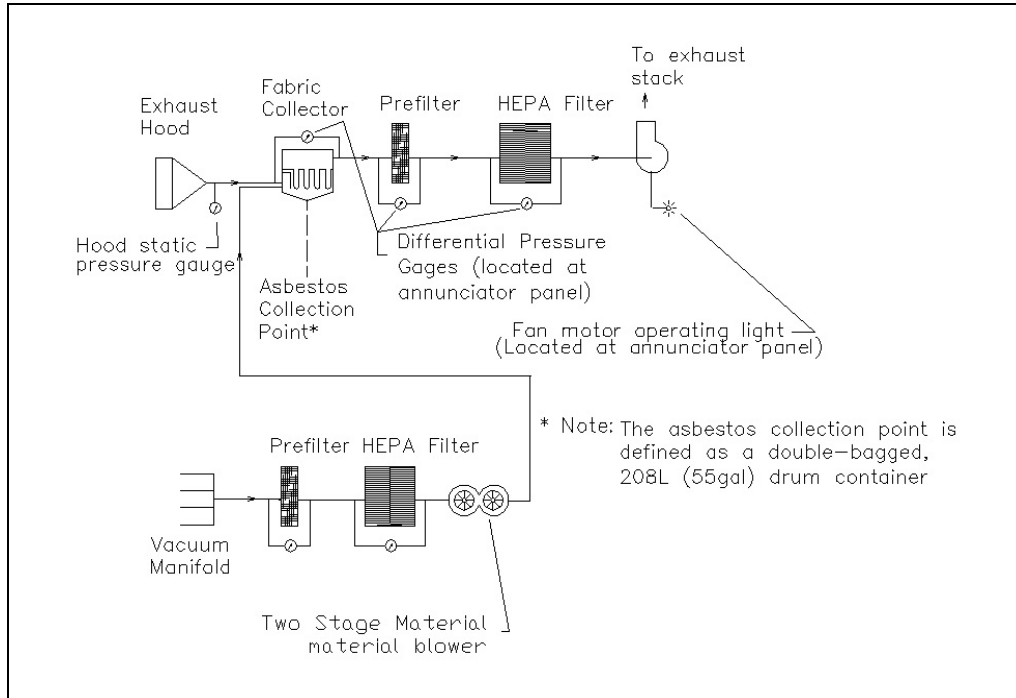

3-5.7.11 Install a prefilter and a HEPA filter in front of the blower to prevent it from becoming contaminated.

3-5.7.12 Design the vacuum system duct to balance with the exhaust system duct where the two systems connect.

3-5.7.13 Use manufacturer guidance to design vacuum system and TM 5-805-4 as preliminary guidance.

3-5.8 **Replacement Air.** Design replacement air systems with fan inlet guide vanes, variable speed motors, or "eddy current clutch" units to maintain a pressure (relative to the atmosphere) ranging from 12.4 to 24.9 Pa scale (-0.02 to -0.05 inches watergauge (wg)) in the shop spaces.

a. Maintain the pressure in decontamination areas, the equipment room, and dirty locker rooms within a range of -2.49 to -9.96 Pa (-0.01 to -0.04 inches wg). Maintain the pressure in clean spaces within a range of +4.98 to +12.4 Pa (+0.02 to +0.05 inches wg). For further replacement air system criteria, see paragraph 2-4.5.

b. See paragraph 2-4.5 for further details.

3-5.8.1 **Heating and Air Conditioning.** If necessary, provide heating and cooling according to MIL-HDBK-1003/3.

3-5.9 **System Controls.** Design system controls in accordance with paragraph 2-5 and the following:

- a. Position the annunciator panel at the entrance to the dirty space so operators can monitor operating gauges.
- b. Install static pressure sensors at locations that are representative of average static pressure in each controlled space. This will ensure that desired differential pressures are maintained.
- c. Trigger a timer if pressure varies from the specified range. Select timer that automatically resets if the problem is corrected within 60 seconds.
- d. Trigger both visible and audible alarms if the system cannot correct the difficulty within allotted time. Install multiple alarm beacons if operator's view is obscured during delagging. Monitor the shop's negative pressure continuously, using strip chart recorder, so the operator can detect any pressure changes.
- e. Interlock the hand tool power supply with the ventilation system's on-off switch. This will prevent the use of hand tools without ventilation controls.

3-6 **SAFETY AND HEALTH CONSIDERATIONS.** Consult the local industrial hygienists for required respiratory protection in accordance with 29 CFR 1910.1001 (f) and (g), 29 CFR 1915.1001(g) and (h). See paragraph 2-7.3 for additional information.

CHAPTER 4

OTTO FUEL II FACILITIES

4-1 **FUNCTION.** MK-46 and MK-48 torpedo facilities maintain, prepare, and test torpedoes. MK-46 and MK-48 torpedoes use Otto Fuel II, a toxic monopropellant. Refer to UFC 4-216-02N, *Design: Maintenance Facilities for Ammunition, Explosives, and Toxins* for additional design considerations.

4-2 **OPERATIONAL CONSIDERATIONS.** Operations in a torpedo facilities create a potential for personnel exposure to one or more of the following: (1) Otto Fuel II, (2) Agitene - parts cleaning solvent used in MK-46 shops, (3) hydrogen cyanide - a product of combustion in torpedoes, and (4) mineral spirits - parts cleaning agent used in MK-48 shops.

4-3 **DESIGN CRITERIA.** Design the facilities using general technical requirements in Chapter 2 of this handbook and the specific requirements in this Chapter. Torpedo size differences and maintenance procedures dictate the use of different floor plans and exhaust hood designs for the two types of facilities. Refer to NAVSEA OP5, Volume 1, *Ammunition and Explosives Ashore Safety Regulations for Handling, Storing, Production, Renovation and Shipping* for the specific order of operations. In all cases, the industrial ventilation systems must remove hazardous vapor (from Otto Fuel II, and part cleaning solvent) and products of combustion.

4-3.1 **Exhaust Air for MK-46 Ventilated Spaces.** The MK-46 floor plan in Figure 4-1 optimizes the workflow while allowing the ventilation system to control airborne contaminants. Figure 4-2 shows an elevation view of this floor plan.

4-3.1.1 **MK-46 Standup Backdraft Hood.** Workers uncouple the fuel section and the engine section of the torpedo in teardown operations. During these operations, Otto Fuel II remains in the lines, in the components of the engine section, and in the fuel tank. The residual fuel releases vapor into the air. The defueling and refueling processes also release Otto Fuel II vapor. Use the standup backdraft hood as shown on Figure 4-3 to capture Otto Fuel II vapor in afterbody teardown, fueling, and defueling operations. Design criteria includes:

- a. Capture velocity of 0.762 m/s (150 fpm) at the contaminant source.
- b. Slots sized for 10.2 m/s (2,000 fpm) covered with wire mesh. The wire mesh will prevent debris being drawn into the ventilation system.
- c. Plenum velocity less than or equal to one half of the slot velocity.

Figure 4-1. Layout for the MK-46 fuel/defuel and afterbody breakdown room.

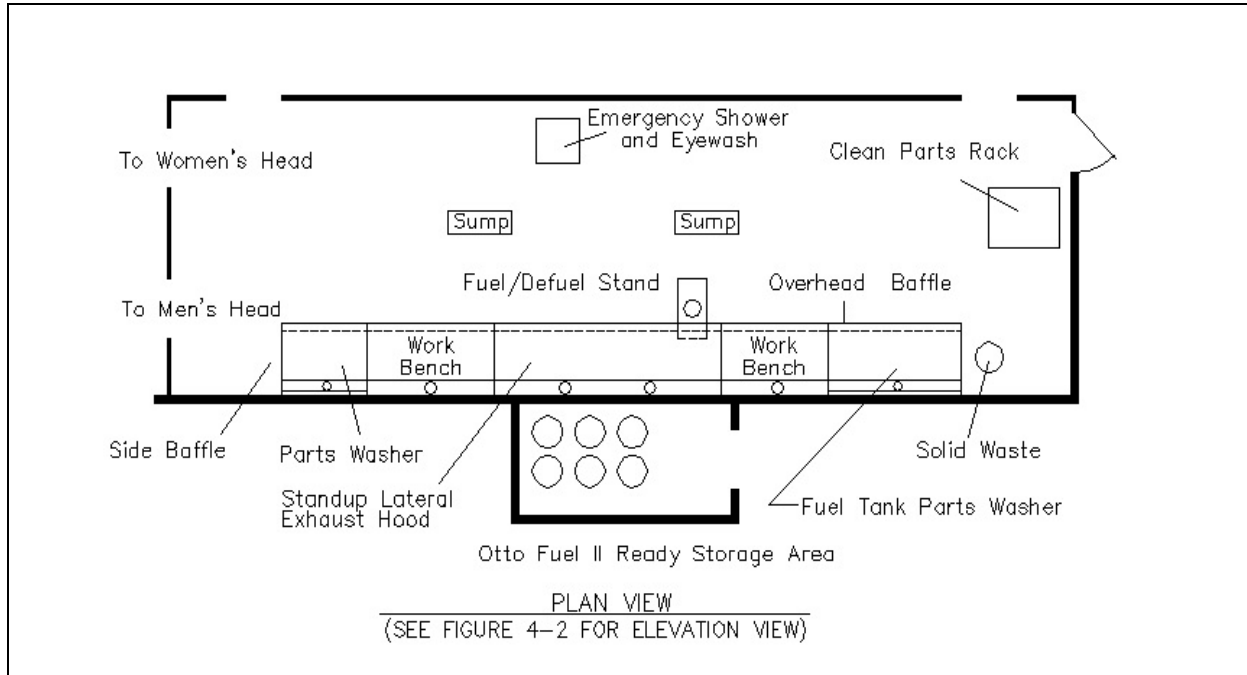

Figure 4-2. Series of hood in the MK-46 shop.

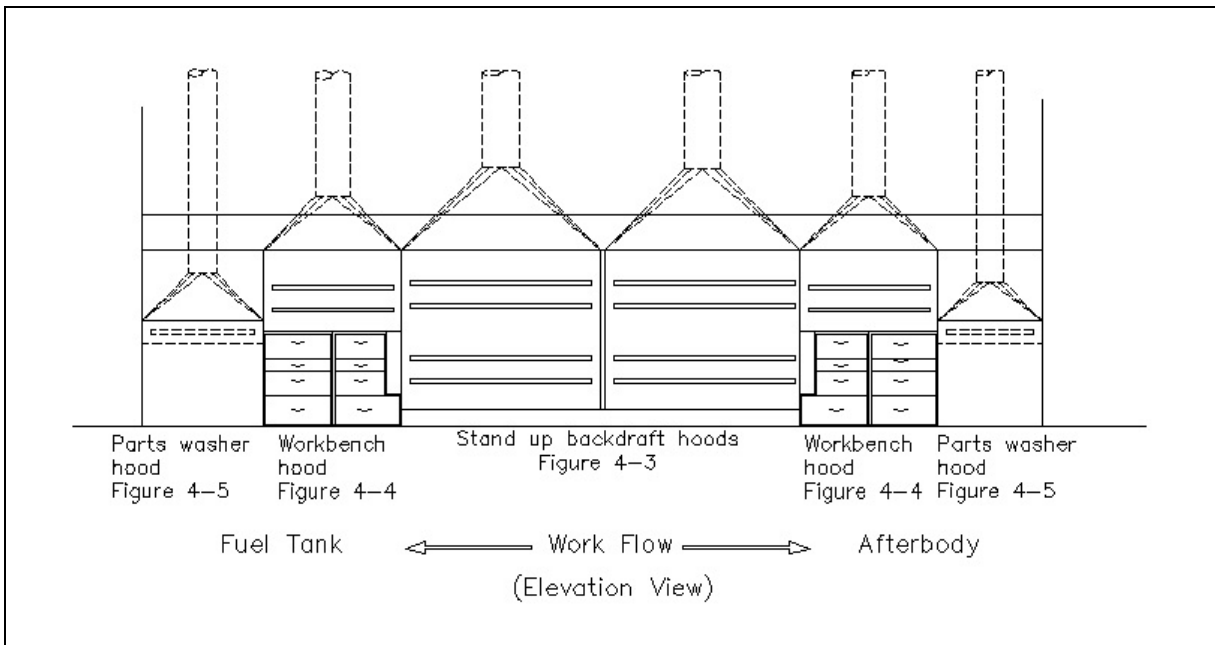
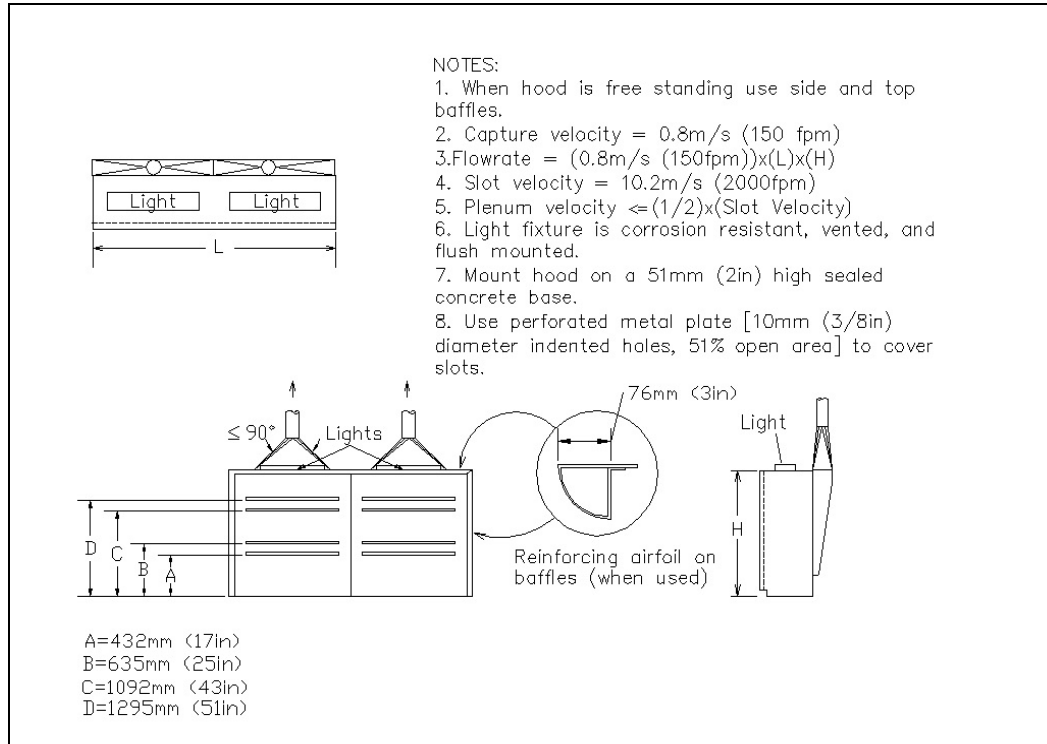

Figure 4-3. MK-46 standup backdraft hood.



d. Hood transitions (takeoffs) with an included angle no greater than 90 degrees. Length of the hood, served by an exhaust plenum, is not to exceed 2.44 m (8 ft). For example, hoods between 2.44 and 4.88 m (8 and 16 ft) in length have two exhaust takeoffs.

e. Baffles to control airflow from the sides and top of the hood bank as shown on Figure 4-3.

4-3.1.2 **MK-46 Workbench Hood.** After defueling and decoupling, workers lift the fuel and engine sections onto two different ventilated workbenches. They remove the stabilizing baffles in the fuel section, inspect, and wipe them clean before loading the baffles into the parts washer. Personnel also dismantle the engine section to inspect the engine, fuel pump, and seawater pump before loading them into the parts washer. Design a backdraft exhaust hood, as illustrated in Figure 4-4, to control contaminants generated by these workbench operations.

4-3.1.3 **MK-46 Parts Washer Hood.** Design parts washer as shown on Figure 4-5 to clean off oils and excess Otto Fuel II from torpedo components. The parts washer cover must automatically close in case of fire in accordance with NFPA 34, *Standard for Dipping and Coating Processes Using Flammable or Combustible Liquids*. Design the parts washer large enough to completely enclose the work piece. Design the parts washer deep enough to allow a minimum clearance of 153 mm (6 in) between the liquid level and the exhaust slot when the tank is full of parts. Position the parts washer next to the workbenches to shorten the work path and optimize ventilation control.

Figure 4-4. MK-46 workbench hood.

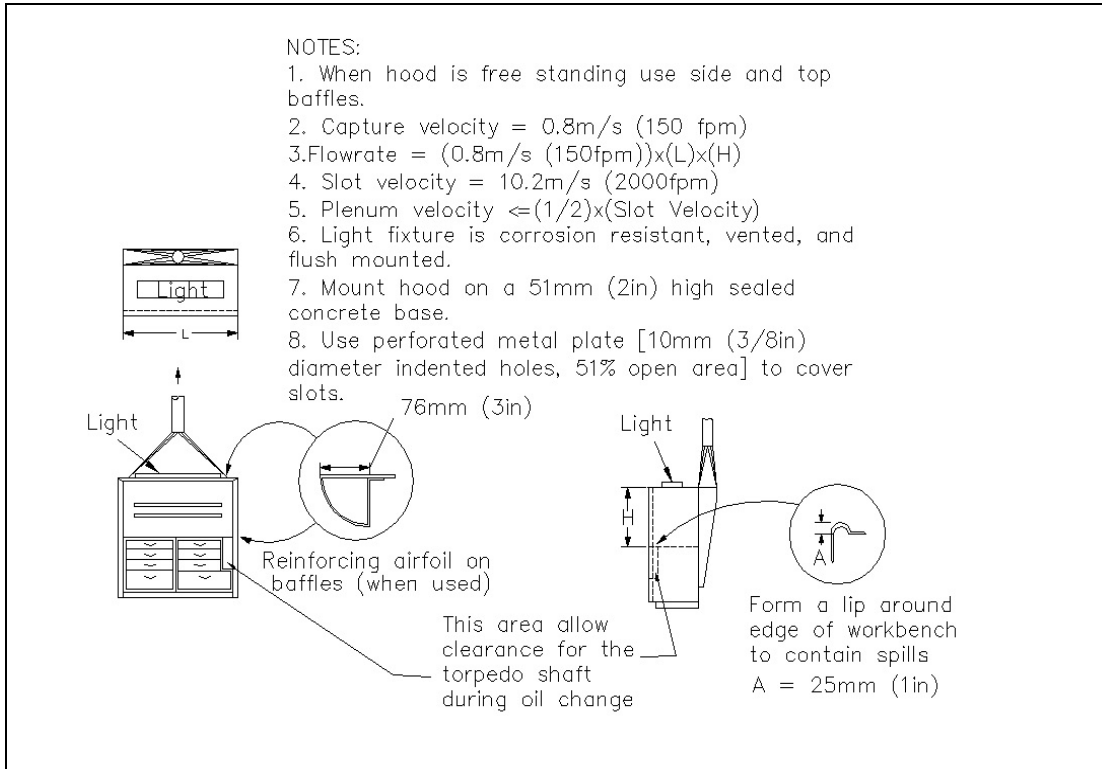
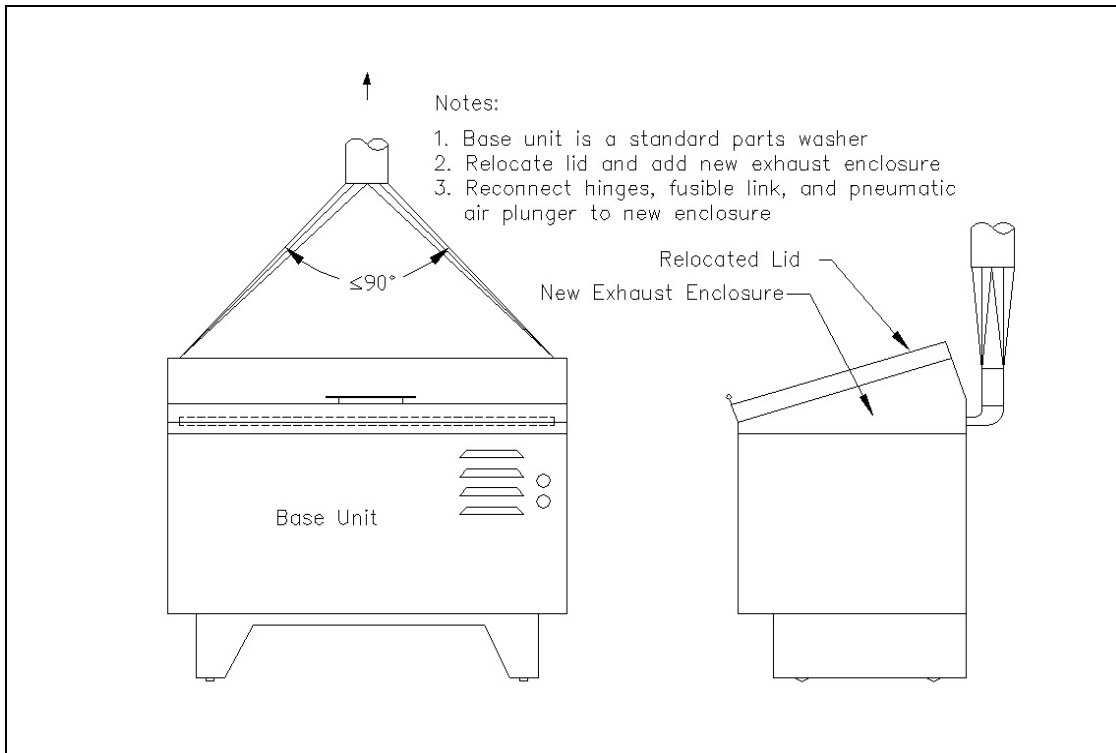
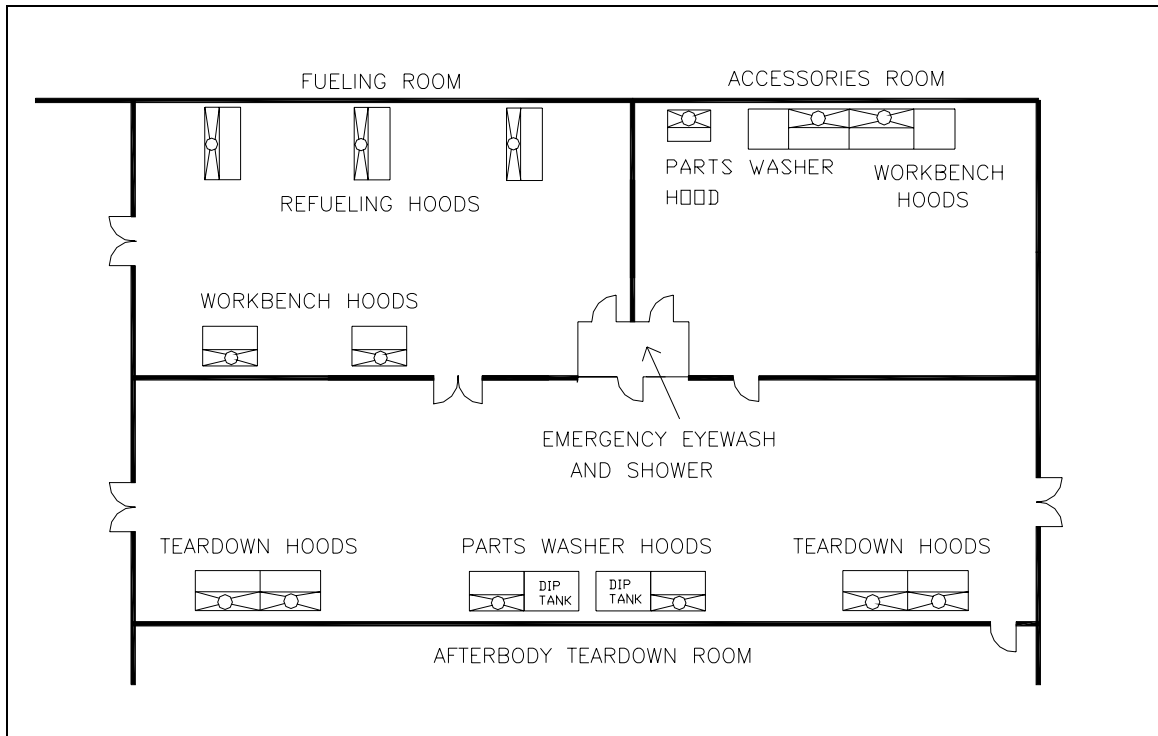

Figure 4-5. MK-46 parts washer hood.



4-3.2 **Exhaust Air for MK-48 Ventilated Spaces.** The floor plan shown in Figure 4-6 optimizes the work path while allowing the ventilation system to control airborne contaminants. Obtain detailed MK-48 exhaust hood drawings from Naval Underwater Systems Center, Code 8113.

Figure 4-6. Typical MK-48 ventilated space layout.



4-3.2.1 **MK-48 Afterbody Teardown Hood.** Workers uncouple the fuel section and the engine section of the torpedo in the teardown operations. During these operations, Otto Fuel II remains in the lines and the components of the engine section, and in the fuel tank. The residual fuel releases vapor into the air. Design the afterbody teardown hood as shown in Figure 4-7 to capture Otto Fuel II vapor. Design the hood using the following criteria.

- a. Install baffles on the top and side of the hood forming a booth.
- b. Install a 7-mm (3-in) airfoil on the outer edge of the hood. The airfoil, bent inward from the baffle, must provide an airfoil effect and prevent turbulence and backflow.
- c. Install lighting that is vented and flush mounted in the overhead baffle as shown on Figure 4-7.
- d. Bolt the hood to the floor, using a continuous natural rubber gasket on hood bottom to create a seal between the hood and the floor.

Figure 4-7. MK-48 afterbody teardown hood.

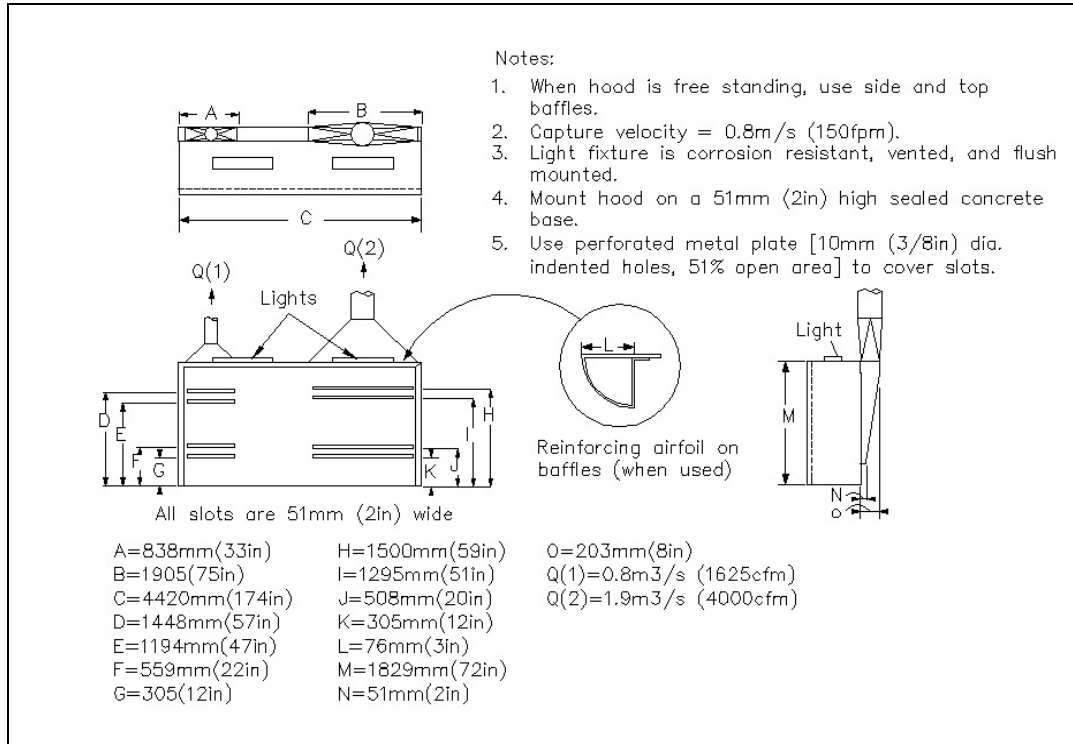

4-3.2.2 **MK-48 Workbench Hood.** After defueling and decoupling, personnel dismantle and inspect the fuel tank and the engine section. They then load components of the fuel tank and the engine section into the parts washer. Design a backdraft exhaust hood as illustrated in Figure 4-8 to control contaminants generated by these workbench operations. Specify the following criteria for workbench hoods:

- A 1850- x 600-mm (72- by 24-in) stainless steel workbench top to support the whole exhaust hood. See Figure 4-8 for dimensions of the hoods.
- A 76-mm (3-in) airfoil rotated inward to prevent turbulence and backflow.
- Lighting that is vented and flush mounted in the top of the exhaust hood.

4-3.2.3 **MK-48 Parts Washer Hood.** Design or modify the parts washers as shown on Figure 4-9. Specify the following criteria for the parts washers:

- Fabricate a new enclosure to mount on top of the parts washer.
- Relocate the cover with a pneumatic plunger and a fusible link assembly.

- c. Install an automatic switch to turn on the exhaust fan when the cover is opened and to turn off the exhaust fan when the cover is closed.

Figure 4-8. MK-48 workbench hood.

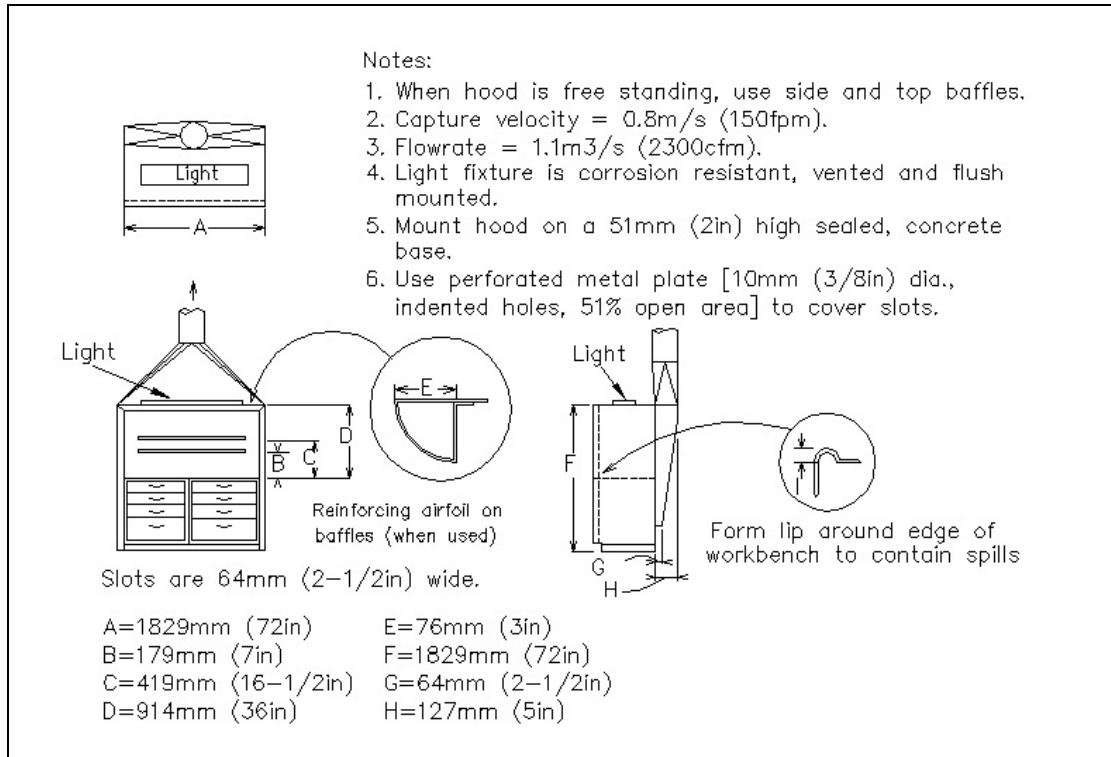
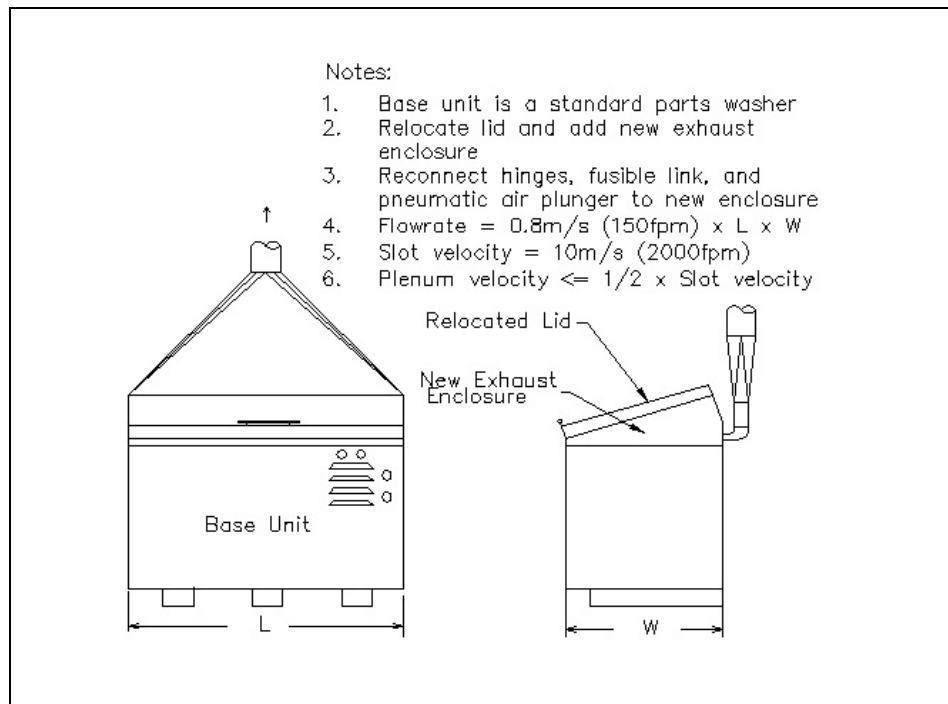

Figure 4-9. MK-48 parts washer hood.



4-3.2.4 Workflow in Afterbody Teardown Room and Accessories Room.

Figure 4-10 illustrates the workflow in both the afterbody teardown room and the accessories room with the proper sequence of hoods.

Figure 4-10. MK-48 hood sequence afterbody teardown and accessories rooms.

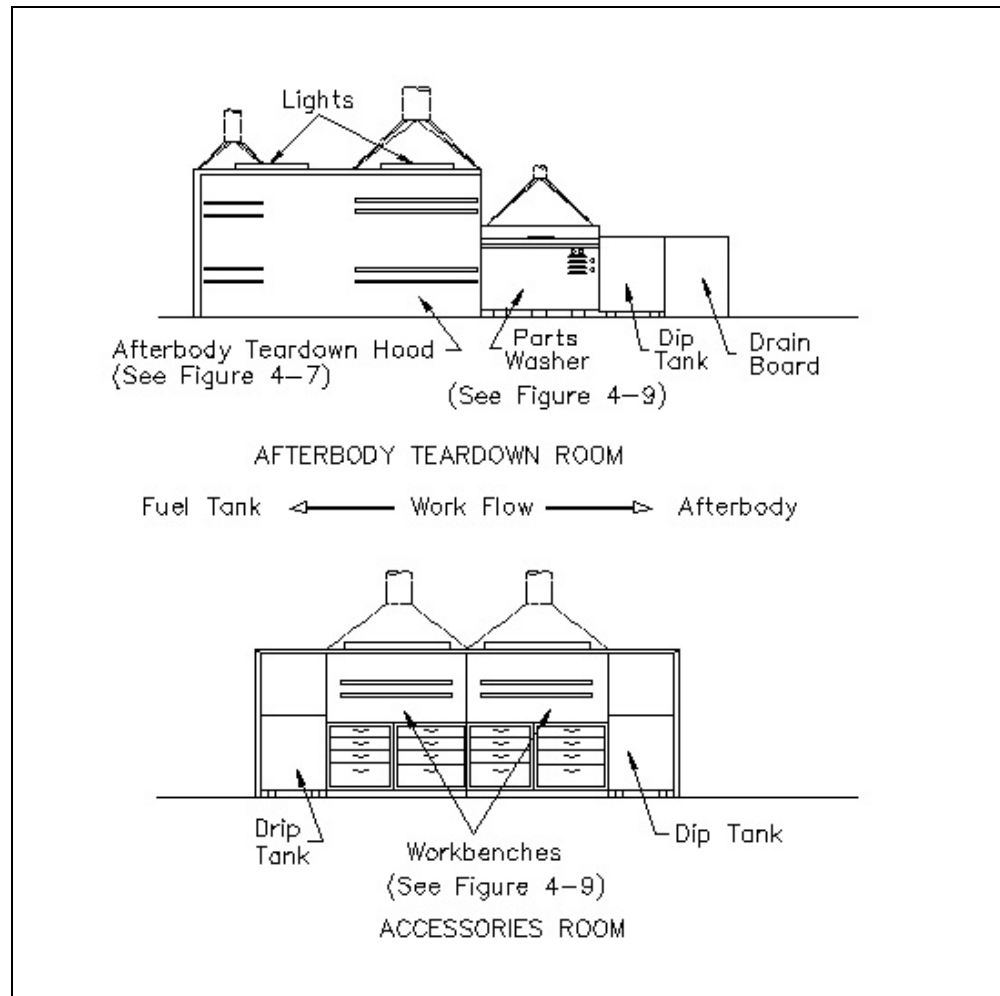

4-3.2.5 **MK-48 Refueling Hood.** Before refueling, personnel connect the hoses from the fueling equipment to the fuel tank. Once the fueling operation has begun, the operator does not need access to the fuel tank, except to see the hose connections. Therefore, design an enclosing hood to reduce ventilation rates and decrease the potential for exposure to a spill during fueling. Design the hood as illustrated in Figure 4-11. Specify the following criteria for the refueling hoods.

- A 76 mm (3-in) airfoil rotated inward to prevent turbulence and backflow.
- Lighting that is vented and flush mounted in the top of the exhaust hood.
- Hood that bolts the floor, using a continuous natural rubber gasket on hood bottom to create a seal between the hood and the floor.

Figure 4-11. MK-48 refueling hood.

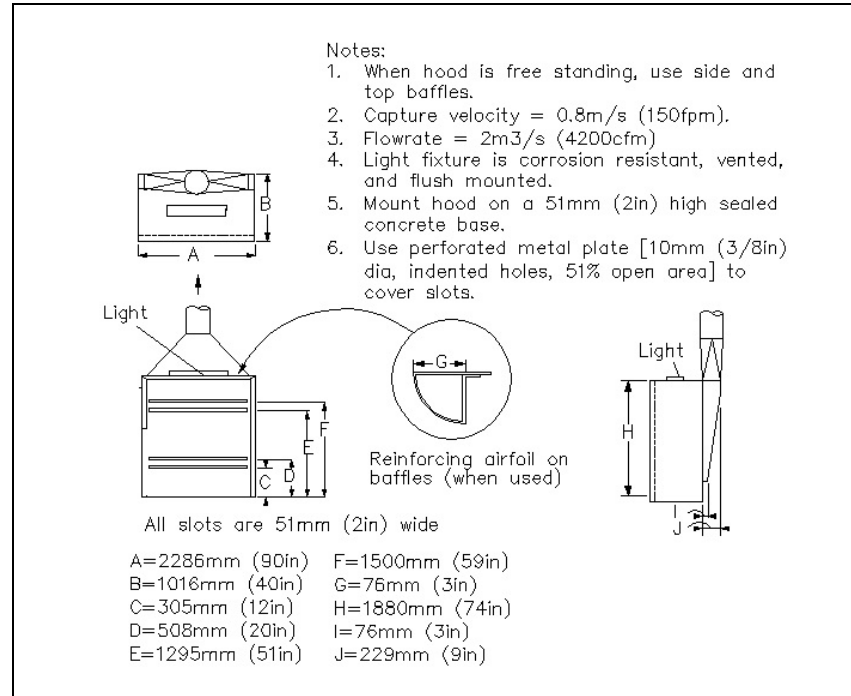

4-3.2.6 **Ductwork.** Follow criteria as specified in paragraph 2-4.1 for both MK-46 and MK-48 shops and the following:

- a. Fabricate all ductwork in contact with Otto Fuel II vapors with (black) carbon steel. Require all joints be either butt welds or flanges.
- b. Size the duct to maintain a minimum transport velocity of 12.7 m/s (2,500 fpm).

4-3.2.7 **Fans.** Select fans as specified in paragraph 2-4.2.

4-3.3 **Weather Stack Design and Location.** Proper dispersion from the stack is critical because Otto Fuel II exhaust is not filtered. See paragraph 2-4.3.

4-3.4 **Air Cleaning Devices.** Due to the quantities and types of contaminants generated by these processes, there is no requirement for air pollution control equipment.

4-3.5 **Replacement Air.** Design replacement air systems to maintain a pressure (relative to the atmosphere) ranging from -5.0 to -14.9 Pa (-0.02 to -0.06 inches wg) in the spaces with a potential for personnel exposure. Maintain the spaces with a low potential for personnel exposure at a differential pressure ranging from 2.49 to 12.4 Pa (+0.01 to +0.05 inches wg).

4-3.5.1 **Quantity and Distribution.** Distribute air to produce laminar flow of air from supply to exhaust in the workspace. Use vertical supply distribution method as

shown on Figure 4-12. Horizontal supply distribution method as shown on Figure 4-13 is adequate if, and only if, all exhaust hoods are located on the wall opposite the supply plenum. See paragraph 2-4.5 for detailed criteria.

Figure 4-12. Vertical distribution method.

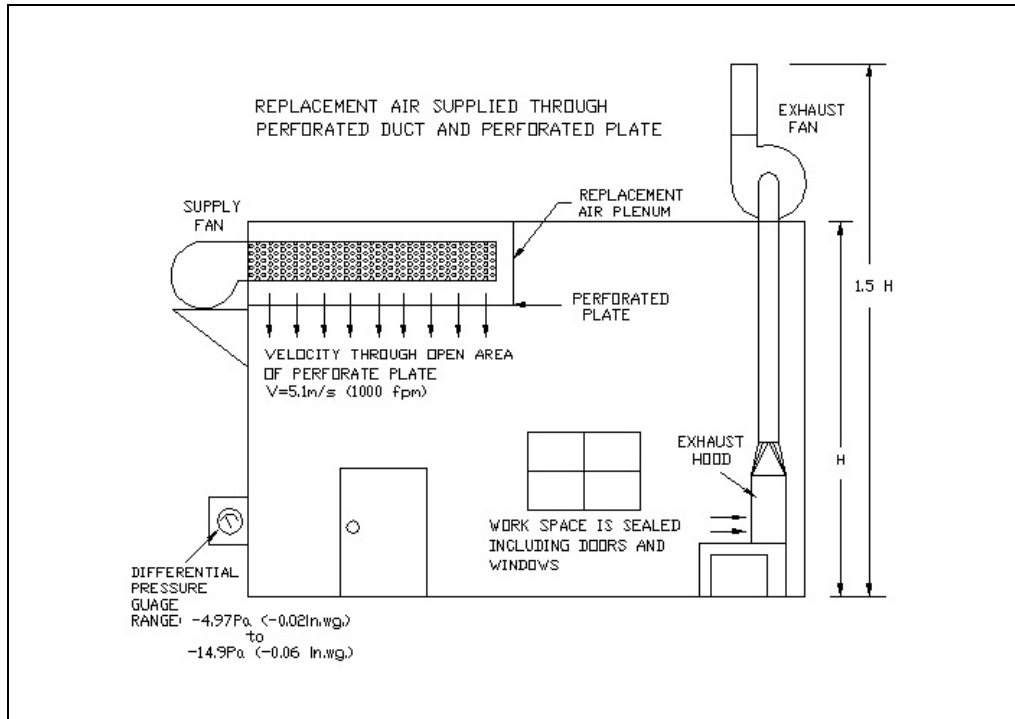
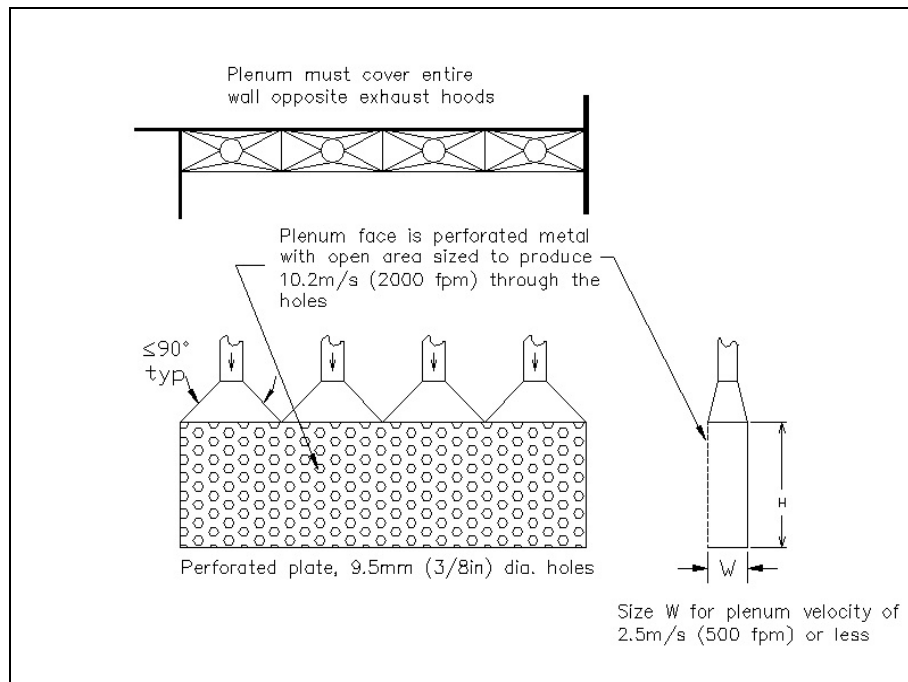

Figure 4-13. Horizontal distribution method.



4-3.5.1.1 **Vertical Distribution Method.** Design a drop ceiling with perforated plate to form a plenum in accordance with paragraph 2-4.5.2.

4-3.5.1.2 **Horizontal Distribution Method.** Design the wall plenum to cover the entire wall opposite the hoods. Size the open area of the perforated sheet for 10.16 m/s (2,000 fpm) through the holes. See Figure 4-13 for more details.

4-3.6 **Heating and Air Conditioning.** Design heating, air conditioning, and humidity control according to MILHDBK 1003/3. Temper the replacement air to provide a minimum winter design temperature of 18 °C (65 °F) and a maximum summer design temperature of 24 °C (75 °F), with a maximum relative humidity of 50 percent. Do not separate the air conditioning system from the replacement air system. See paragraph 2-6.2 for criteria on heat recovery systems. Do not re-circulate exhaust air.

4-4 **SYSTEM CONTROLS.** Design system controls in accordance with paragraph 2-5 and the following:

- a. Position an annunciator panel at the entrance to the space with a potential for personnel exposure so operators can monitor operating gauges.
- b. Install static pressure sensors at locations that are representative of average static pressure in each controlled space. This will ensure that desired differential pressures are maintained.
- c. Trigger a timer if the pressure varies from the specified range. Select a timer that automatically resets if the problem is corrected within 60 seconds.
- d. Trigger both visible and audible alarms if the system cannot correct the difficulty within the allotted time.

4-5 **SAFETY AND HEALTH CONSIDERATIONS.** 29 CFR 1910 requires specific criteria for the safety and health of operators. The physical nature of the work and the use of protective clothing increase the potential for heat stress. Consider cooling the replacement air to reduce this potential. Refer to NAVSEA S6340-AA-MMA-010, *Otto Fuel II Safety, Storage, and Handling Instructions* for complete operational considerations.

4-5.1 **Emergency Eyewash and Shower Stations.** Provide combination emergency eyewash and deluge showers in the immediate area of Otto Fuel II use. Refer to UFC 3-420-01.

CHAPTER 5

FIBERGLASS REINFORCED PLASTIC FABRICATION AND REPAIR FACILITIES

5-1 **FUNCTION.** Fiberglass reinforced plastic (FRP) shops and facilities primarily fabricate and repair aircraft and shipboard components. Both include a shop area, a mechanical equipment area, and a decontamination area (for protective clothing).

5-2 **OPERATIONAL CONSIDERATIONS.** FRP fabrication and repair operations include sanding, buffing, fabric cutting, grinding, lay up, and wet spray up. These operations produce dust and vapor that constitute health hazards. The protective clothing that the workers wear and the physical nature of the work creates a potential for heat stress.

a. Consider using airless spray equipment to reduce hazardous vapors in the shop. Initial cost for this equipment is greater than traditional compressed air systems. Benefits include overspray reduction and less accumulation of resin and fiberglass over the life of the equipment. A disadvantage of these systems is their limited pattern and flow adjustment capability.

b. Consider using low monomer polyester material, closed molding systems or low-VOC resin systems, and airless and air-assisted spray equipment to avoid the need for expensive air pollution devices.

c. Isolate conventional grinding operations from the mixing areas and the lay up and spray up areas. The combined hazard of dust and flammable vapors is potentially explosive. Post signs in the lay up and spray up areas and the mixing area without low volume-high velocity (LVHV) connectors that read:

DANGER
DO NOT GRIND, CUT, OR SAW
FIBERGLASS IN THIS AREA

5-3 **FLOOR PLAN.** Figure 5-1 shows a typical floor plan for a fabrication and repair facility. The workers enter the clean locker rooms through the administrative area. They put on protective outerwear and proceed to the shop area. After performing their work, shop personnel vacuum, then discard their protective outerwear in containers near the entrances to the locker rooms. The workers then enter the locker rooms where they remove the remainder of their work garments.

Figure 5-1. Floor plan for FRP facility.

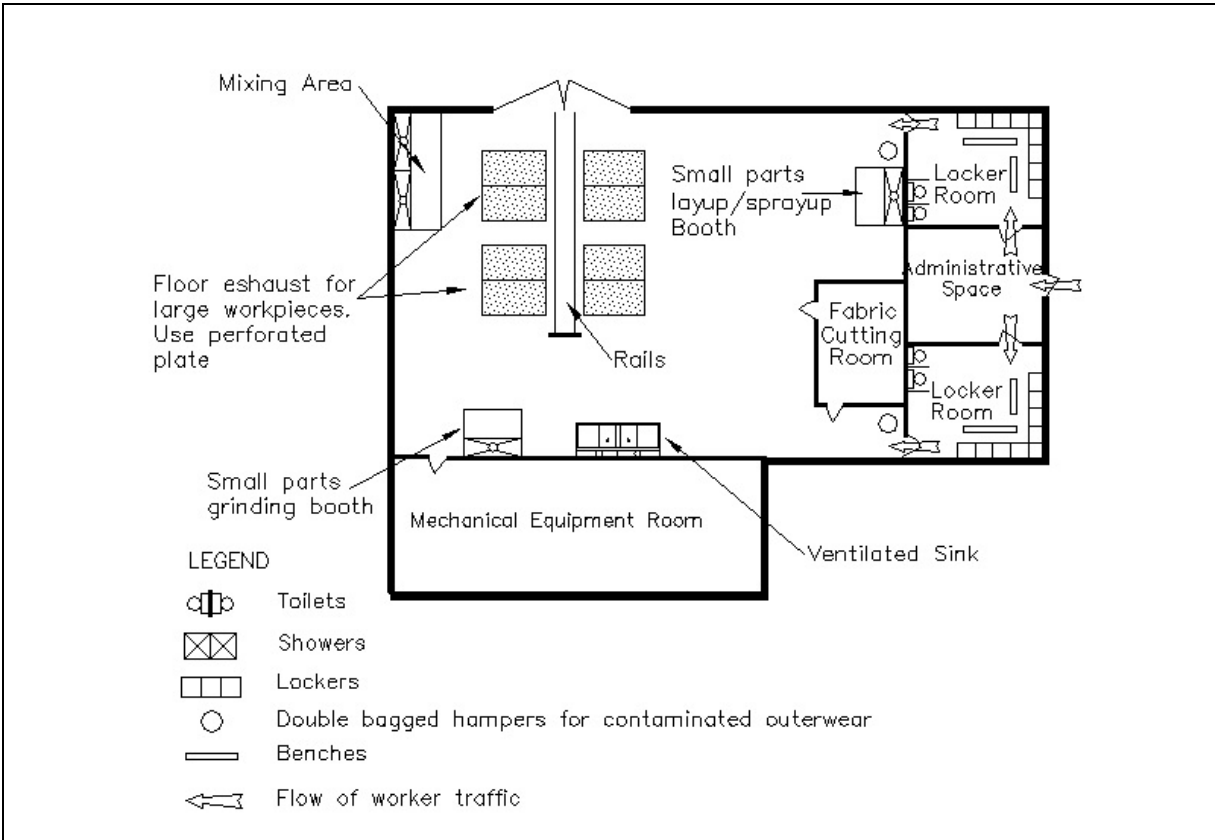

5-4 **DESIGN CRITERIA.** Design the facility using general technical requirements in Chapter 2 of this UFC and the specific requirements in this Chapter.

5-4.1 **Exhaust Air System.** Provide an exhaust system that captures contaminated air generated during FRP fabrication and repair operations. Refer to Chapter 2 of this UFC; UFC 3-600-01; NFPA 33, *Standard Spray Application Using Flammable and Combustible Materials*; NFPA 68, *Guide for Venting Deflagrations*; NFPA 91, *Standard for Exhaust Systems for Air Conveying of Materials*; NFPA 654, and the specific requirements of this Chapter.

5-4.2 **Hood Design.** The sizes and shapes of work pieces in FRP fabrication and repair facilities vary. Design separate hoods for processes producing only particulate and only vapor, and both particulate and vapor. Consider a molding system that completely encloses the work piece if the facility repeatedly manufactures the same work piece. Design exhaust hoods to enclose all processes to the greatest possible extent without inhibiting operations. Baffle all exhaust hoods to reduce cross drafts and improve hood efficiency. Table 5-1 summarizes recommended exhaust hoods, capture velocities, and air pollution control devices for each operation.

Table 5-1. Recommended Hood, Capture Velocity, and Air Pollution Device

Operation (expected contaminant)	Hood Type	Recommended Capture Velocity (m/s (fpm))	Air Cleaning Device (see notes)
Chemical Mixing (vapors)	Workbench (Figure 5-2)	0.51 m/s (100)	1
Lay up (Vapors)	Workbench/Floor Exhaust (Figure 5-3)	0.51 m/s (100)	1
Spray up (Vapors)	Spray up Booth (Figure 5-4)	0.51 m/s (100)	1
Grind,Cut,Saw (Particulate)	Workbench/Floor Exhaust (Figure 5-3)	0.76 m/s (150)	2
Cleanup (Vapors)	Ventilated Sink (Figure 5-5)	0.51 m/s (100)	3 or 1
Hand Tools (Particulate)	LVHV Vacuum System	Not applicable	2

NOTES: (1) Determined by the local air pollution regulatory agency,
(2) fabric collector, and
(3) substitute an aqueous emulsion cleaner for acetone.

5-4.2.1 **Plenum Velocity.** Design the plenum velocity at least one-half, but no greater than, the velocity through the perforated plate or layered prefilter to create an even airflow over the hood face. Design the hood-to-duct transition with an included angle of no more than 90 degrees.

5-4.2.2 **Hood Length.** Specify that the length of the hood served by each exhaust plenum will not exceed 2.44 m (8 ft). For example, hoods between 2.44 and 4.88 m (8 and 16 ft) in length will have two exhaust takeoffs. Provide cleanout doors in the plenum to allow removal of accumulated particulate.

5-4.2.3 **Portable Hand Tools.** Use portable hand tools with LVHV vacuum systems for sawing, cutting, and grinding on all work pieces. Ensure that the tools, with their vacuum hoses, are properly sized for the work piece internal angles and curvature. LVHV systems are described in paragraph 5-4.7.

Figure 5-2. Workbench hood.

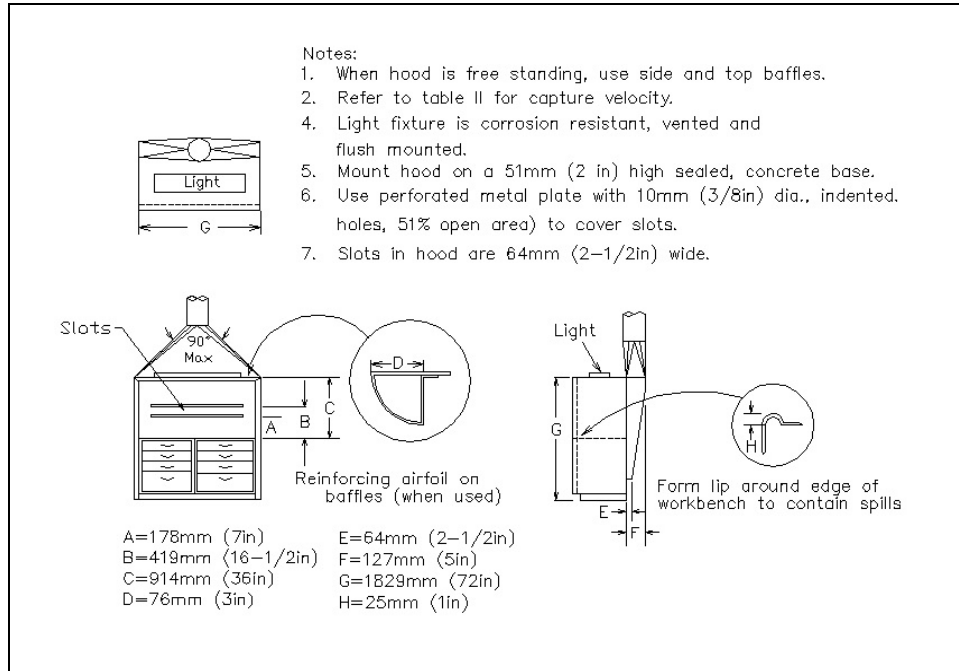
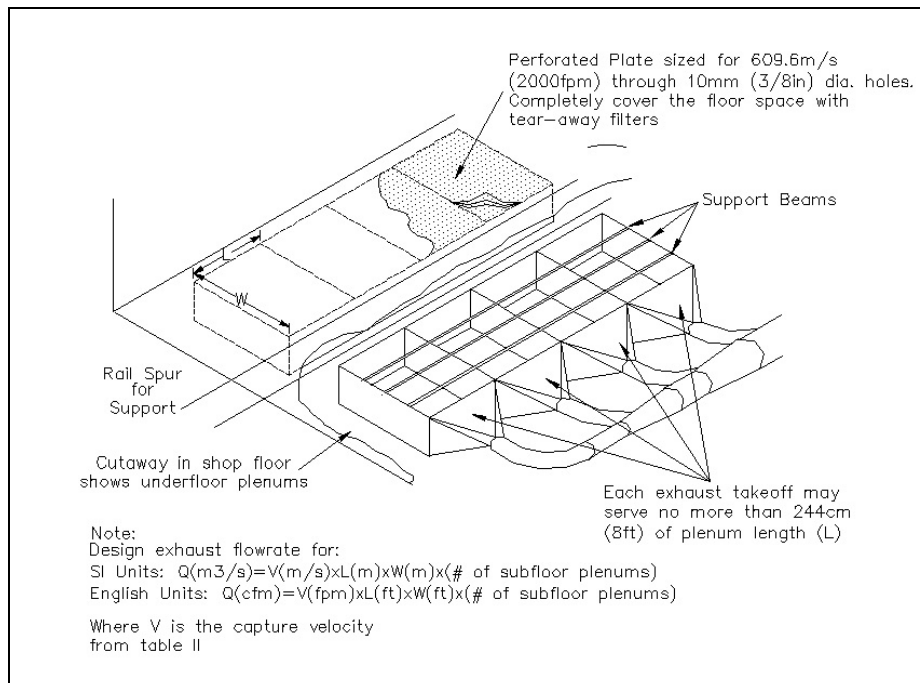

Figure 5-3. Floor exhaust.



NOTE: Mount the work piece on a mechanism for easy rotation. This will reduce the dead air space that occurs when working on raydomes, boat hulls, and other large objects.

Figure 5-4. Spray up booth.

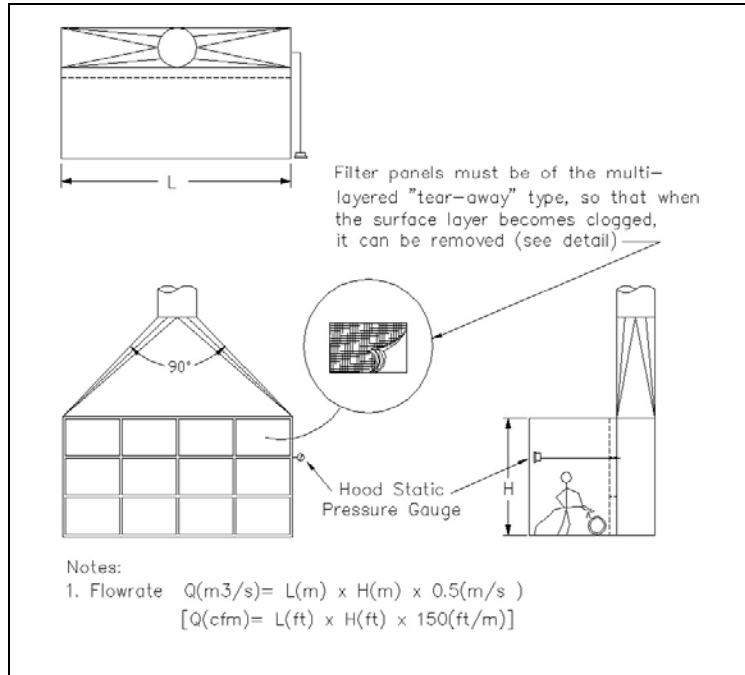
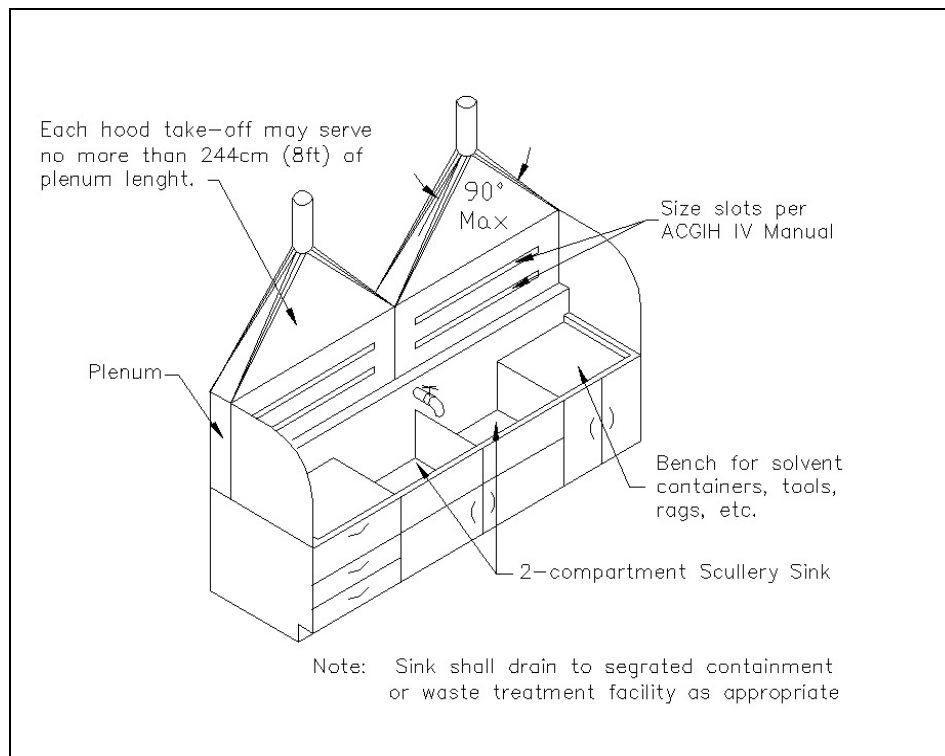

Figure 5-5. Ventilated sink.



5-4.2.4 **Spray Up Booths.** Design a spray up booth as shown on Figure 5-4. Use the spray up hood design in shops where spray up and lay up are performed in the same booth. Separate operations in this booth from any cutting, grinding, and sawing operations when conventional hand tools are used.

5-4.2.5 **Ventilated Workbench and Sink.** Design a ventilated workbench as shown in Figure 5-2 for small work pieces. Use a similar workbench for resin preparation and mixing as shown on Figure 5-5. Eliminate the drawers and increase the size of the hood face by extending it to the floor if 55-gallon drums are used during resin preparation. Use aqueous emulsion cleaners to reduce styrene and acetone exposure.

5-4.3 **Ductwork.** Design a 17.8 m/s (3,500 fpm) minimum transport velocity for LVHV hand tools, and grinding and spray up operations to prevent particulate material from collecting in the ductwork.

a. Size the ductwork carrying vapor generated during lay up and mixing operations for a minimum transport velocity of 12.7 m/s (2,500 fpm). Use sheet metal as duct material since it is non-combustible. Route the ductwork directly to fans located outdoors. See paragraph 2-4.1 for further information on ductwork.

b. Consult with a fire protection engineer and use UFC 3-600-01 to design a fire protection system for the ductwork when required. Condensation of flammable vapors, i.e. styrene and acetone, may occur and pool in the ductwork as it passes through an area with a lower temperature.

5-4.4 **Fans.** See paragraph 2-4.2 for general considerations.

5-4.5 **Weather Stack Design and Location.** See paragraph 2-4.3 for exhaust stack design guidance.

5-4.6 **Air Cleaning Devices.** Use separate air cleaning devices for grinding, buffing and polishing operations where particulate material is generated. Use separate air cleaning devices for lay up and mixing operations where flammable vapors are generated. Consult the air pollution control authorities for details on local requirement.

5-4.6.1 **Grinding Operations and Hand Tools.** Use a fabric collector for grinding operations and LVHV hand tools. Consider using a disposal chute with a motor-driven rotary air lock in shops with a large particulate volume.

5-4.6.2 **Spray Up Operations.** Spray-up operations release a combined contaminant of wet resin laden fiber and organic vapors. Therefore, separate spray up operations from all other operations. Install an air-cleaning device for vapors. Install layered prefilters on the spray up hood face instead of the perforated plate to prevent wet airborne resin from hardening in the ductwork and collectors. Peel off and discard a layer of the prefilter when its surface becomes loaded as indicated by the hood static pressure gauge. This continues until only the base filters remain. After that, replace the

entire prefilter section. Specify a filter material that is not damaged by the styrene and acetone vapor produced in FRP facilities.

5-4.7 Industrial Vacuum System. Install a vacuum system; see Figure 5-6, to exhaust fibers, dry resin and dust from LVHV hand tools when they are used. The vacuum system also allows workers to conduct shop cleanup and to decontaminate their protective outerwear. ACGIH IV Manual, Chapter 10, gives design details and illustrates power tools using LVHV vacuum systems. The large size and high terminal velocity of the particulates produced by the hand tools requires a high velocity vacuum take-off hood for each tool. Generally, design the takeoff hood into the tool's safety guard.

Figure 5-6. Exhaust system schematic.

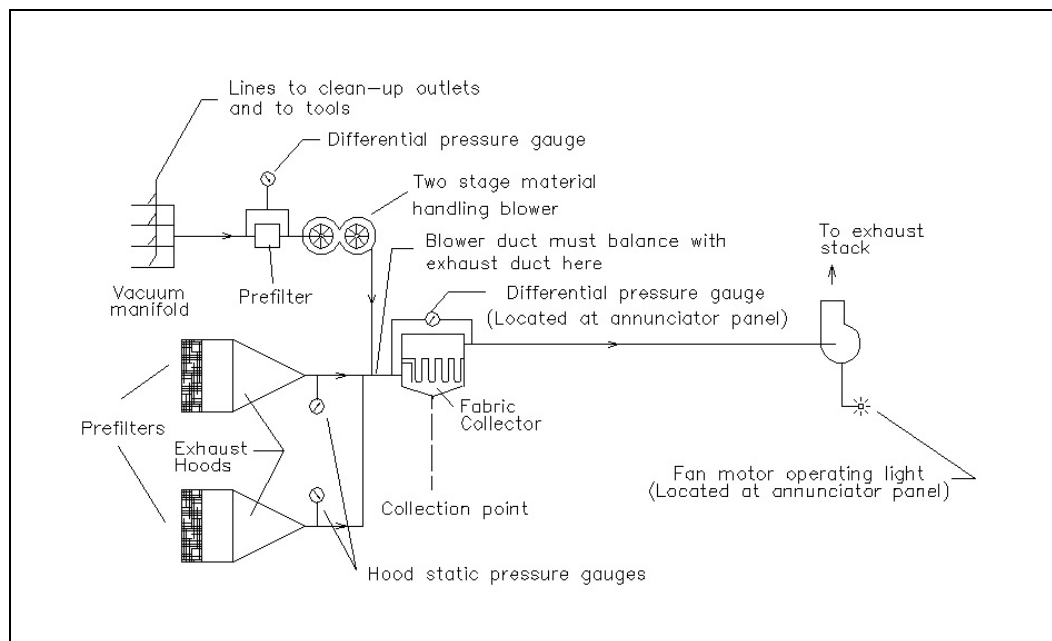

5-4.7.1 Vacuum System Design. Design the vacuum system in accordance with the following criteria:

- a. Ensure each take-off hood produces the proper capture velocity. This is the most important consideration in designing the vacuum system. Design the hood to capture contaminants as close as possible to the point of generation. Design vacuum systems to capture contaminants within 12.7 mm (1/2 inch) of the source.
- b. Design the capture air-stream to have a velocity of two to three times the generation velocity for particles of 20 to 30 micrometers (20 to 30 microns.) Design for an additional velocity of:
 1. Four to five times the generation velocity to pull the particles up through 300 U.S. standard mesh, or

2. Six to eight times the generation velocity to pull particles up through 20 U.S. standard mesh.
- c. Design the air volume for no less than two parts of air to one part of material to be captured by weight.
- d. Design the vacuum hose length less than 7.6 m (25 ft). Locate inlet valves 9 to 10.7 m (30 to 35 ft) apart when a 7.6-m (25-ft) length of hose is used. Locate the tool vacuum hose connection on the ends of the workbench underneath the stands. Size the hose based on the following:
 1. Air volume per hose.
 2. Number of hoses to be used simultaneously.
 3. Transport velocities.
- e. Use a multistage centrifugal blower for the vacuum system. Size the blower according to the following:
 1. The total system pressure loss associated with the total number of hoses to be used simultaneously.
 2. The maximum exhaust flow-rate entering the inlet of the blower.
- f. Feed the blower directly into the dirty side of the fabric collector, see Figure 5-6, used by the industrial exhaust system to minimize the number of FRP collection points.
- g. Use the manufacturer's data to complete the design because the LVHV system design data is largely empirical.

5-5 **REPLACEMENT AIR.** Design replacement air systems to maintain a pressure (relative to the atmosphere) ranging from -4.97 to -14.9 Pa (-0.02 to -0.06 in wg) in the shop space and the protective clothing decontamination areas. Maintain the clean spaces at a positive pressure relative to dirty spaces. See paragraph 2-4.5 for further details. Provide each ventilated space with a dedicated replacement air system. Conduct a study of the curing requirements of the resin before specifying temperature and humidity ranges. Do not re-circulate exhaust air.

5-6 **SYSTEM CONTROLS.** Design system controls in accordance with paragraph 2-5 and the following:

- a. Position the annunciator panel at the entrance to the dirty space so operators can monitor operating gauges.

b. Install static pressure sensors at locations that are representative of the average static pressure in each controlled space. This will ensure that desired differential pressures are maintained.

c. Interlock the hand tool power supply with the ventilation system's on/off switch. This will prevent the use of hand tools without ventilation controls.

5-7 **SAFETY AND HEALTH CONSIDERATIONS.** See paragraph 2-7. Provide combination emergency eyewash and deluge showers in the workspace. See UFC 3-420-01 for performance requirements on combination units.

CHAPTER 6

ABRASIVE BLASTING FACILITIES

6-1 **FUNCTION.** Workers prepare the surface of aircraft, shipboard, mechanical, utility, and other equipment in abrasive blasting facilities for surface coating, welding, and other operations. This Chapter does not apply to temporary blasting enclosures.

6-2 **OPERATIONAL CONSIDERATIONS.** Silica sand is prohibited from use in fixed location enclosures. Avoid using agricultural media (e.g. peach pits, rice hulls, walnut shells). They are particularly susceptible to explosions.

6-3 **DESIGN CRITERIA.** Apply the general technical requirements of Chapter 2 and the specific requirements of this Chapter to ensure the proper function, operation and maintenance of an abrasive blasting facility. Use this information when assembling a specification package for an enclosure manufacturer or inspecting an enclosure already in place.

6-3.1 **Exhaust Air.** Determine the type of dust hazard and the minimum average air velocity through the blasting enclosure in accordance with 29 CFR 1910.94(a), *Abrasive Blasting*; ANSI Z9.4, *Abrasive Blasting – Ventilation & Safe Practices for Fixed Location Enclosures*, sections 4, 5, 6 and A7; NFPA 68, *Standard for the Processing and Finishing of Aluminum*; NFPA 69, *Standard on Explosion Prevention*; NFPA 70; NFPA 91; and NFPA 654. Refer to NFPA 65; NFPA 480, *Storage, Handling, and Processing of Magnesium*; NFPA 481, *Storage Handling and Processing of Titanium*; NFPA 482, *Storage, Handling, and Processing of Zinc*; and NFPA 485, *Storage, Handling, and Processing of Lithium* when blasting on materials containing aluminum, magnesium, titanium, zirconium and lithium, respectively.

6-3.2 **Blasting Cabinets.** Install baffles around air inlets to prevent abrasive material from escaping from the cabinet. Use a minimum inward air velocity of 2.54 m/s (500 fpm) at all operating openings. Discharge the exhaust air outside the building.

6-3.3 **Walk-in Blasting Enclosures.** Design the enclosure so that the air flows from either the ceiling to the floor (downdraft), Figure 6-1, or from one wall to the opposite wall (crossdraft), Figure 6-2, and the following:

- a. Consider the geometry of the room and how work pieces are positioned within the room, and the number of workers and their locations when selecting a downdraft or a crossdraft design.
- b. Minimize the area of a blasting room to reduce the volumetric airflow rate. Allow at least 1.22 m (4 ft) of clearance between the work piece and the ceiling, walls, and doors of the room. Add extra clearance to accommodate internal fixtures such as tables and hoists.

c. Isolate the abrasive blasting rooms from other processes, functions and activities, whenever possible. Place blasting rooms outside, away from administration and other spaces. Protect the blasting room and related equipment from rainwater and moisture intrusion. As a minimum, put a roof or cover over the blasting room.

6-3.3.1 **Downdraft.** The downdraft design provides superior visibility. In addition, a downdraft design is preferred since contaminated air is usually drawn away from the worker's breathing zone. When more than one operator works in an enclosure, contaminated air generated from one operation is less likely to migrate into the other operator's breathing zone. Use a perforated plate with 9.53-mm (3/8-in) diameter holes, as shown in Figure 6-1, to uniformly distribute the airflow over the entire cross-section of the enclosure. Use a perforated duct inside the plenum to help evenly pressurize the plenum.

Figure 6-1. Downdraft blast enclosure.

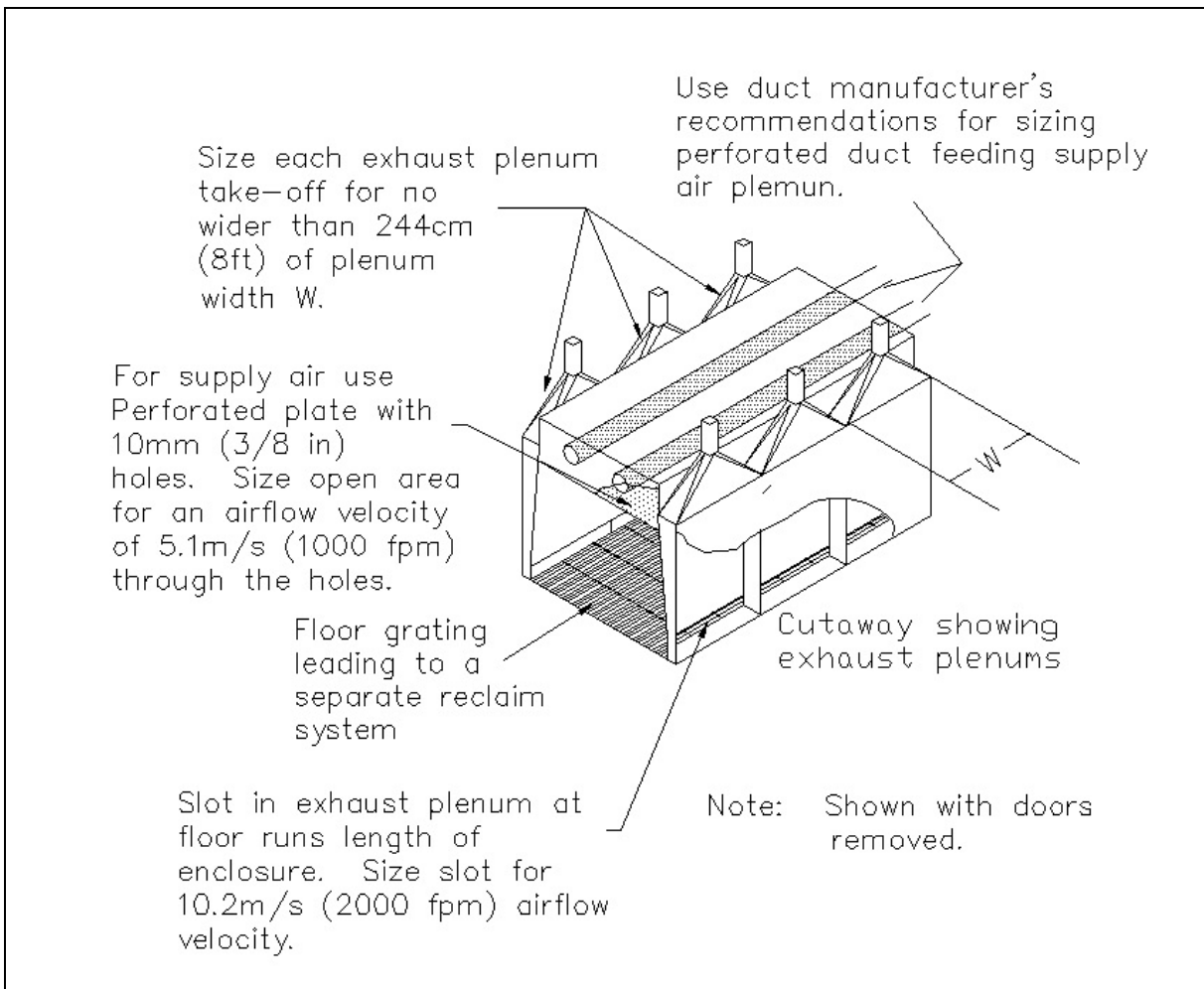

6-3.3.2 **Crossdraft.** Consider the work locations of operators when positioning the replacement and exhaust air plenums. Do not allow any operator to blast upstream of coworkers. Use a perforated plate with 9.53 mm (3/8-in) diameter holes; see Figure

6-2, to uniformly distribute airflow over the entire cross-section of the enclosure.

Figure 6-2. Crossdraft blast enclosure.

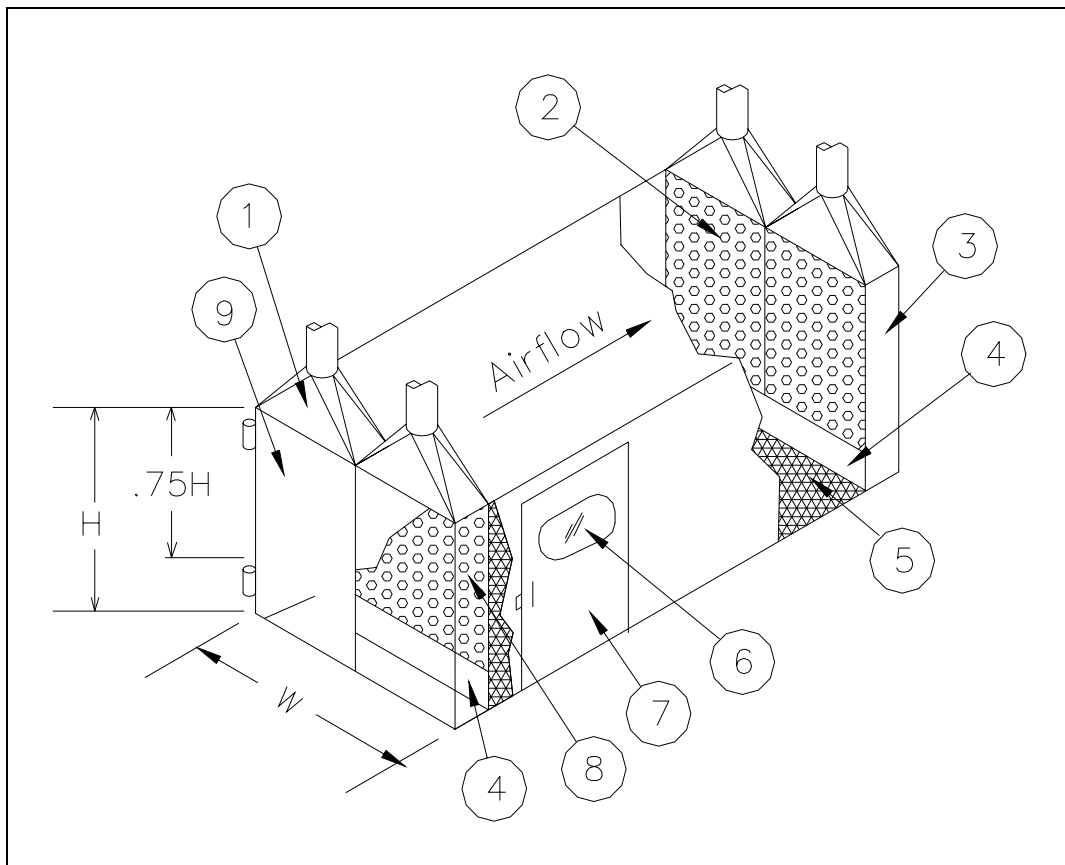

NOTES:

1. For mechanically supplied replacement air, use maximum plenum take-off width of 2.44 m (8 ft). Plenum serves as material door.
2. Perforated plate with 9.53 mm (3/8-in) holes. Size open area for an airflow velocity of 10.16 m/s (2000 fpm) through holes.
3. Size the exhaust plenum for a maximum plenum velocity of 5.08 m/s (1000 fpm). Size any supply plenum for a maximum plenum velocity of 2.54 m/s (500 fpm).
4. Lift up flap to remove material from behind plenum.
5. Floor grating.
6. Observation window.
7. Personnel door.
8. Perforated plate, from floor to ceiling and wall-to-wall, with 9.53 mm (3/8-in) holes. Size open area for an airflow velocity of 5.080 m/s (1000 fpm) through holes.
9. Hinged plenum equipment doors.

6-3.4 **Access Doors and Observation Windows.** Provide an observation window and an access door in accordance with 29 CFR 1910.94(a)(3)(i)(d) and (e) and

ANSI Z9.4 sections 5.3 and 5.4. Position the observation window in the blast room walls and door as necessary so workers inside the room can be seen from outside the room at all times. Use several doors and windows in large rooms. Provide emergency exits on opposing walls. Make personnel and equipment doors operable from both inside and outside of the room.

6-3.5 **Air Cleaning Devices.** See paragraph 2-4.4. Design in accordance with 29 CFR 1910.94(a)(4)(iii) and ANSI Z9.4, section 6.3. Consider using a pulse-jet, pleated paper cartridge type dust collector and the following.

- a. Replaceable explosion vents on the collector hoppers in accordance with NFPA-68.
- b. Platforms leading to all elevated access hatches.
- c. Fan located on the clean side of the collector.
- d. Place dust collectors outside of the building for all blasting applications. NFPA 65 specifically requires that the air pollution equipment be located outside when blasting on aluminum or aluminum alloys.

6-3.6 **Recirculation.** Do not recirculate exhaust air when operations generate toxic materials. If exhaust air recirculation is permitted, design the system in accordance with the ACGIH IV Manual, ANSI Z9.4 (section 6.3) and ANSI Z9.7, 29 CFR 1910.1025 (lead), and 29 CFR 1910.1027 (cadmium). The outdoor air volumetric airflow rate must be sufficient to keep the contaminant below 25 percent of the MEC.

6-3.7 **Media Reclamation.** Design in accordance with 29 CFR 1910.94(a)(4)(ii) and ANSI Z9.4, section 6.2. Do not integrate the exhaust ventilation system with the media recovery system.

- a. Protect the media recovery system and ductwork from moisture and rainwater intrusion to keep the media from caking and plugging up the system.
- b. Use mechanical recovery systems such as rotary screw conveyors for heavy media (steel shot).
- c. Consider using pneumatic recovery system instead of mechanical recovery system for plastic media.

6-3.8 **Ductwork.** See paragraph 2-4.1. Do not use spiral lock seam duct. Size the exhaust ductwork to maintain a minimum transport velocity of 17.8 m/s (3,500 fpm). Specify flat backed elbows per the ACGIH IV Manual, Chapter 5, Figure 5-25.

6-3.9 **Fans.** See paragraph 2-4.2. Use centrifugal fans with backward curved blades, whenever possible. Centrifugal fans with radial blades are less efficient, but still acceptable. Place the exhaust fan and the outlet ductwork outside of the building.

6-3.10 **Weather Stack Design and Location.** See paragraph 2-4.3 for design guidance.

6-3.11 **Replacement Air Ventilation Systems.** See paragraph 2-4.5. Design dedicated mechanically supplied replacement air systems to maintain room static pressures (relative to the atmosphere) ranging from -4.98 to -14.9 Pa (-0.02 to -0.06 in wg).

Blast booths often do not have mechanical replacement air. In this case, there is no control over the room static pressure for non-mechanical replacement air systems. The extra negative pressure reduces exhaust fan performance. If mechanically supplied replacement air is not feasible, ensure that the room static pressure and the resistance through filters and louvers are included when sizing the exhaust fan.

6-3.12 **Heating and Air Conditioning.** See paragraph 2-6.2

6-3.13 **System Controls.** Design system controls in accordance with paragraph 2-5 and the following.

- a. Install static pressure sensors at locations that represent the average static pressure in each blasting room. This will enhance monitoring and maintenance of desired blasting room pressures.
- b. Interlock the blasting tool power supply with the ventilation system's on-off switch. This will prevent the use of blasting tools without ventilation controls.

6-4 **SAFETY AND HEALTH CONSIDERATIONS.** See paragraph 2-7, 29 CFR1910.94(a)(5), and ANSI Z9.4, section 7, for general requirements. Consider the following.

6-4.1 **Respiratory Protection.** Follow the guidelines in 29 CFR 1910.94(a)(5) for respiratory protection requirements. The operator must wear a continuous-flow, air-line respirator that covers the head, neck, and shoulders. Consider providing each respirator hood with an adjustable, vortex-type climate control system.

6-4.2 **Air Supply and Air Compressors.** For large booths, consider providing multiple air hose connection points along the perimeter of the enclosure to accommodate work in various parts of the booth.

6-4.3 **Noise.** See paragraph 2-7.2. Carefully select the blast nozzle. Nozzle noise generation depends greatly on the discharge velocity. Consider using sound barriers or dampening materials on enclosure walls. Protect the dampening material

from abrasive blast as much as possible. Isolate the air compressor, media recirculation, and air pollution equipment to minimize noise exposure.

6-4.4 **Hygiene Facilities.** Provide change rooms and shower following guidelines such as OSHA regulations, DOD, or Branch Service requirements.

CHAPTER 7

WOOD SHOP FACILITIES

7-1 **FUNCTION.** Wood shops differ in size and function. Use the design criteria in this chapter as a general guideline for developing ventilation systems for wood shops.

7-2 **OPERATIONAL CONSIDERATIONS.** A properly designed ventilation system will control the dust level within the shop. Exposure to wood dust may lead to health problems. The accumulation of wood dust can create explosion and fire hazards. Even if a ventilation system is installed to collect most of the dust, manual cleaning at each machine and throughout the shop is still necessary. Restrict woodworking exhaust systems to handling only wood dust. Do not connect any other process that which could generate sparks, flames, or hot material to a woodworking exhaust system.

7-3 **FLOOR PLAN LAYOUT.** Contact the shop personnel who will be working with the machinery to get their input on workflow and specific equipment. Design the ventilation system to complement equipment layout and minimize housekeeping.

7-4 **DESIGN CRITERIA.** Design the facility using general technical requirements in Chapter 4 of this UFC, NFPA 664, *Prevention of Fires and Explosions in Wood Processing and Woodworking Facilities* and the specific requirements in this chapter.

7-4.1 **Exhaust Air System.** Calculate the system capacity on the basis that the system operates with all hoods and other openings, such as floor sweeps, open. Refer to the ACGIH IV Manual, Chapter 10, for determining the exhaust flow rate for specific wood shop machines.

7-4.1.1 **System Layout.** Lay out the system to meet the shop requirements. Consider locating machines with the greatest hood resistance as close as possible to the fan. In most cases, ductwork is located along the ceiling and walls; however, running ductwork under removable grates or panels in the floor may reduce duct lengths and leave more working space around machinery. Refer to NFPA 650, *Pneumatic Conveying Systems for Handling Combustible Particulate Solids* and 664 for information on wall penetrations and clearances.

7-4.1.2 **Plenum Exhaust System.** An alternative to the tapered system is a plenum system, described in the ACGIH Manual, Chapter 5. A plenum system allows equipment to be move equipment in the shop and may be more efficient. Ducts can be added or removed, as equipment needs change. See the ACGIH IV Manual Chapter 5 for further considerations.

7-4.2 **Hood Design.** Provide a hood for each operation that produces dust. This includes sawing, shaping, planing, and sanding operations. Design and position all hoods so the wood dust will fall, be projected, or be drawn into the hood in the direction

of the airflow. Construct hoods of noncombustible materials. Ensure the hoods do not interfere with worker operations. In some cases, the exhaust hood may be utilized as a safety guard. Refer to the ACGIH IV Manual, Chapter 10 for woodworking hood designs. Modify the drawings as necessary to meet the specific equipment and process requirements.

7-4.3 Floor Sweeps. If the design includes floor sweeps, include a means, such as magnetic separators, to prevent scrap metal from entering the system. Figure 7-1 shows a basic floor sweep design. The floor sweep is only opened during shop clean up. If the system design calculations indicate that, when opened, the floor sweep provides a transport velocity of less than 17.78 m/s (3,500 fpm,) design the system to include floor sweeps in the normally opened position without a hinged cover.

Figure 7-1. Floor sweep

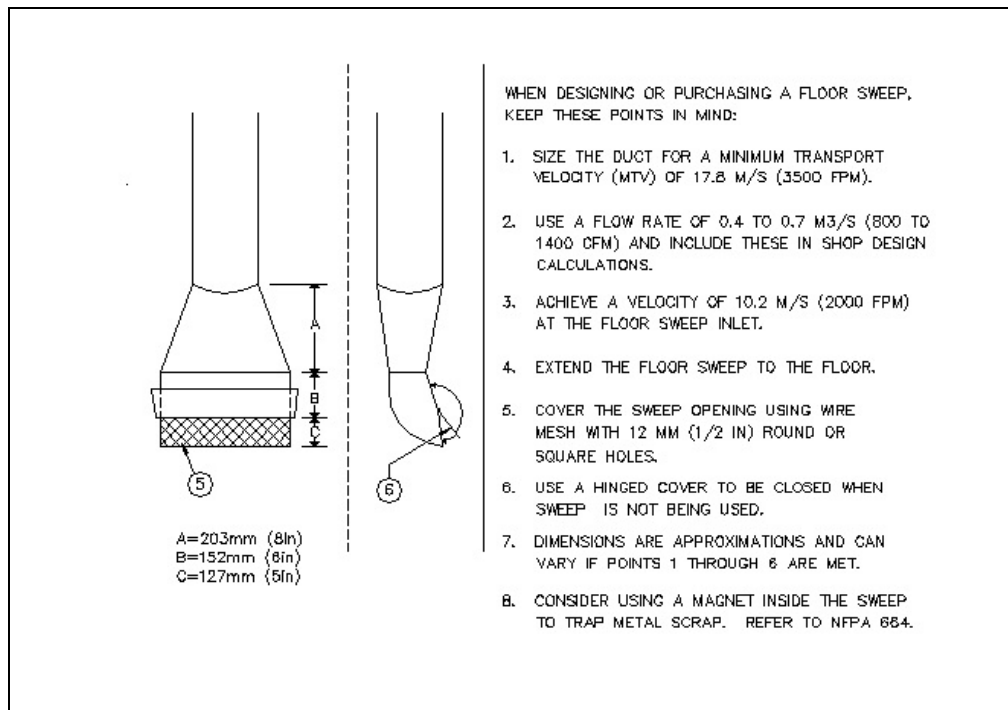

7-4.4 Ductwork. See paragraph 2-4.1 for general ductwork design. See NFPA 664 for specific requirements on wood shop ductwork construction. Size the ductwork to maintain a minimum transport velocity as specified in the ACGIH IV Manual, Chapter 10, Woodworking. Use only metal ductwork and conductive flexible hose. Bond and ground all ductwork in accordance with NFPA 664. The ductwork must be designed on the basis that all hoods and other openings connected to the system are open.

7-4.5 Blast Gates. Provide blast gates only for the specific purpose of balancing the airflow. Do not use blast gates to isolate equipment from the exhaust system with the intent to reduce the overall airflow requirement. When possible, install blast gates on horizontal runs and orient the gate so the blade is on the top half of the duct and opens by pulling the blade towards the ceiling. When possible, blast gates

must be installed at a location not easily accessible to shop personnel. After final balancing and acceptance, secure the blade and mark its position so that it can be returned to the balanced position if inadvertently moved. When the blast gate cannot be placed out of the reach of shop personnel, then lock the blade in position. For example, drill a hole through the body and blade of the gate and then insert a bolt and tack weld it.

7-4.6. **Duct Support.** If sprinkler protection is provided in the duct, horizontal ductwork must be capable of supporting the weight of the system, plus the weight of the duct half-filled with water or material being conveyed, whichever has the higher density.

7-4.7 **Clean Out Panels.** See paragraph 2-4.1.

7-4.8 **Exhaust Fans.** See paragraph 2-4.2.

7-4.9 **Weather Stack Design and Location.** See paragraph 2-4.3.

7-4.10 **Air Cleaning Devices.** See paragraph 2-4.4. Locate the air-cleaning device outside the building.

7-4.11 **Heating and Air Conditioning.** Provide heating and cooling according to MIL-HDBK-1003/3.

7-5 **SAFETY AND HEALTH CONSIDERATIONS.** See paragraph 2-7 and the following items.

a. Refer to section 7.2.2 of ANSI O1.1, *Woodworking Machinery, Safety Requirements* for personal protective equipment.

b. Provide a means for separately collecting and disposing of any metal scrap such as nails, band iron, or any wood containing metal. Do not use the woodshop ventilation system to pick up these materials.

c. Avoid the use of wood painted with paints containing lead, hexavalent chromium, cadmium, or coated with wood preservatives. Otherwise, consult an industrial hygienist to determine the exposure level and the level of respiratory protection needed.

d. Use sharp and clean blades at the correct feed rate to generate less heat. The generated heat can raise the wood or wood-containing product to ignition temperature that could start a fire.

CHAPTER 8

BATTERY MAINTENANCE FACILITIES

8-1 **FUNCTION.** Battery maintenance facilities contain space and equipment for receiving, cleaning, testing, charging, and issuing batteries. Sizes range from a small booth to a room with storage area. In these facilities, batteries are not in operation while being charged. Two types of electrochemical battery in general use are lead-acid and nickel-cadmium (NICAD). This chapter does not address battery-post repair operation. Design of facilities for installation of battery banks, such as UPS, will be covered in a different UFC.

8-2 **OPERATONAL CONSIDERATIONS.** Batteries generate a small amount of hydrogen and other gases while they are being charged or discharged. Hydrogen build-up could lead to an explosion. Provide ventilation to keep the hydrogen concentration below 25 percent of the LEL (LEL = 4 percent) to prevent an accumulation of an explosive mixture.

8-3 **DESIGN CRITERIA.** Design the facilities using NAVFAC DM-28.4, *General Maintenance Facilities*. Design the ventilation system using general technical requirements in chapter 4 of this UFC and the specific requirements in this Chapter.

8-3.1 **Exhaust System.** Design exhaust ventilation to have both high-level exhaust for hydrogen and low-level exhaust for electrolyte spills (acid fumes and odors). Distribute one-third of the total exhaust flow rate to the high-level exhaust to ventilate all roof pockets. Locate low-level exhaust at a maximum of 304.8-mm (1-ft) above the floor. See Figure 8-1 for a floor plan of a battery maintenance room.

8-3.1.1 **Minimum Flow Rate Calculation.** To determine the amount of required volumetric airflow rate, the amount of hydrogen produced must be calculated for the total number of battery cells in the room. The volume of hydrogen generated is governed by the amount of charging current (ampere) supplied to the fully charged battery by the charger. Significant amounts of hydrogen are evolved only as the battery approaches full charge. To determine a minimum required volumetric airflow rate, use the following formulas:

$$C = (FC/100) \times AH \times K \times N \quad (1)$$

$$Q = (C/60) / PC \quad (2)$$

Figure 8-1. Ventilation system for battery maintenance facilities.

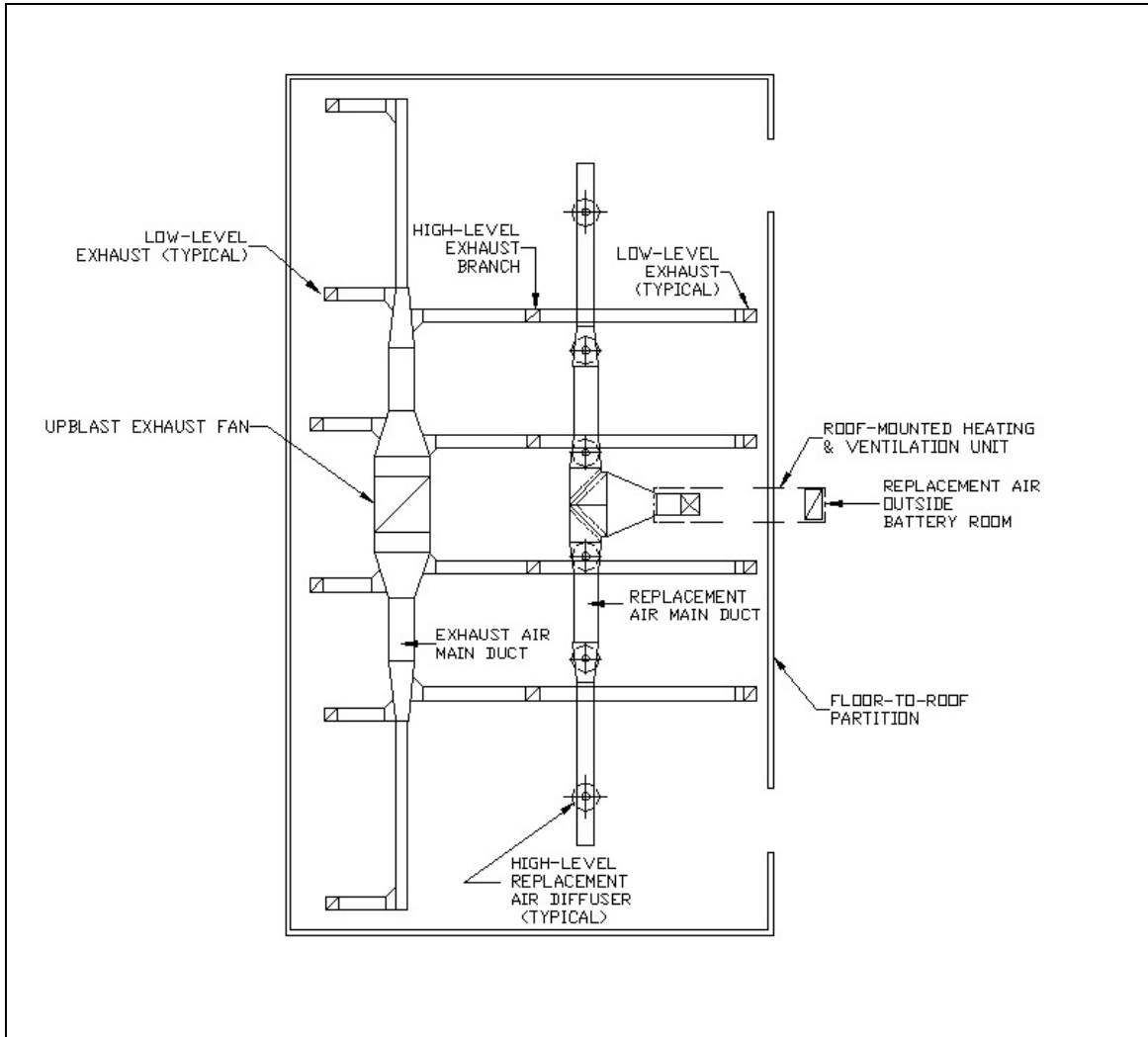

Where:

- C = Hydrogen generated, in cubic feet per hour (cfh).
- FC = Float current per 100 ampere-hour. FC varies with battery types, battery condition, and electrolyte temperature. It will double/halve for each 15 degrees F (8 degrees C) rise/fall in electrolyte temperature.
- AH = Ampere hour.
- K = A constant of 0.016 cubic feet of hydrogen per 1 ampere-hour per cell (at sea level and 77 degrees F ambient temperature).
- N = Number of battery cells.

Q = Minimum required ventilation airflow rate, in cubic feet per minute (cfm).

PC = Percent concentration of hydrogen allowed in room (PC = 0.01 to keep the hydrogen concentration at 1 percent).

Formula (2) assumes complete mixing of the air inside the battery maintenance facility. In most cases, use a safety factor k to determine the actual ventilation rate. See Figure 2.1 of the ACGIH IV Manual to select a “k” value.

$$Q_A = Q \times k \quad (3)$$

Q_A = The actual volumetric ventilation rate, in cubic feet per minute (cfm), which can be expressed in air change per hour (ACH) using the following formula:

$$ACH = Q_A \times 60 / \text{Room Volume} \quad (4)$$

Example. Per manufacturer specification, one fully charged lead calcium cell, at 77 degrees F (25 degrees C), will pass 0.24 amperes of charging current for every 100 ampere-hour cell capacity, measured at the 8-hour rate, when subject to an equalizing potential of 2.33 volts. Calculate the required rate of ventilation for a battery bank consisting of 182 cells. Each cell has a nominal 1,360-ampere hours capacity at the 8-hour rate and being equalized at an electrolyte temperature of 92 degrees F (30 degrees C).

At 92 degrees F (30 degrees C), FC is doubled

$$FC = 0.24 \text{ amp} \times 2 = 0.48 \text{ amp}$$

$$AH = 1360 \text{ amp hr}$$

$$K = 0.016 \text{ ft}^3/\text{amp hr cell}$$

$$C = \frac{0.48 \text{ amp}}{100 \text{ amp hr}} \times 1360 \text{ amp hr} \times 0.016 \frac{\text{ft}^3}{\text{amp hr cell}} \times 182 \text{ cell} = 19 \frac{\text{ft}^3}{\text{hr}}$$

$$Q = \frac{19 \frac{\text{ft}^3}{\text{hr}} \times \frac{1 \text{ hr}}{60 \text{ min}}}{0.01} = 32 \frac{\text{ft}^3}{\text{min}} \quad (5)$$

Assume a room size of 8,000 cubic feet (226.5 cubic meters) with a safety factor of k = 2, charging 3 banks of battery.

$$Q_A = 32 \frac{\text{ft}^3}{\text{min}} \times 3 \times 2 = 192 \frac{\text{ft}^3}{\text{min}}$$

$$\text{ACH} = 192 \frac{\text{ft}^3}{\text{min}} \times \frac{60 \text{ min}}{\text{hr}} \times \frac{1 \text{ AC}}{8000 \text{ ft}^3} = 1.44 \frac{\text{AC}}{\text{hr}} \quad (6)$$

8-3.2 **Ductwork.** Design ductwork in accordance with paragraph 2-4.1. Use FRP or PVC ductwork.

8-3.3 **Fans and Motors.** Select fans in accordance with paragraph 2-4.2. Use AMCA 201, Type B spark resistant construction and explosion proof motors. Fans must have non-sparking wheel. Locate the motor outside of the air stream.

8-3.4 **Weather Stack Design and Location.** Avoid re-entry of exhaust air by discharging the exhaust high above the roof line or by assuring that no window, outdoor intakes, or other such openings are located near the exhaust discharge. See paragraph 2-4.3 for additional considerations.

8-3.5 **Air Cleaning Device.** Due to the quantities and types of contaminants generated by this process, there is no requirement for air pollution control equipment.

8-3.6 **Replacement Air.** Design a replacement air system in accordance with paragraph 2-4.5. Design the replacement air volumetric flow rate for approximately 95 percent of the exhaust airflow rate to provide a negative pressure inside the maintenance facility. Use 100 percent outside air. Do not re-circulate exhaust air back to the maintenance facility.

8-3.7 **System Controls.** Design system control in accordance with paragraph 2-5 and the following criteria:

- a. Interlock the charging circuit and the exhaust fan in the shop to ensure chargers will not operate without ventilation.
- b. Provide indicator light showing that the exhaust system is functioning properly.

8-4 **SAFETY AND HEALTH CONSIDERATIONS.** In accordance with 29 CFR 1926.403, *Battery Rooms and Battery Charging*, provide the following.

- a. Face shields, aprons, and rubber gloves for workmen handling acids or batteries.
- b. Facilities for quick drenching of the eyes and body, within 7.6 m (25 ft) of the work area for emergency use. See UFC 3-420-01 for eyewash station requirements.

- c. Facilities for flushing and neutralizing spilled electrolyte, and for fire protection.
- d. Non-slip rubber insulating matting in front of all charging benches to protect personnel from electric shock and slipping hazards
- e. Warning signs, such as: "Hydrogen, Flammable Gas, No Smoking, No Open Flames."

CHAPTER 9

PAINT SPRAY BOOTHS

9-1 **FUNCTION.** Paint spray booths provide surface finishing capabilities for a wide range of parts, equipment, and vehicles. Paint spray booth sizes range from bench type units for painting small parts, to large walk-in booths or rooms for painting vehicles, tractors or large equipment. Design aircraft maintenance hangars in accordance with Chapter 10 of this UFC.

9-2 **OPERATIONAL CONSIDERATIONS.** During paint spray operations, paint is atomized by a spray gun and then deposited on the object being painted. Depending on the application equipment and spray method used, transfer efficiencies vary greatly. Transfer efficiency is the amount of paint solids deposited on a surface divided by the total amount of paint sprayed, expressed as a percentage.

a. Use equipment with a high transfer efficiency, such as electrostatic or high volume low pressure (HVLP) spray guns, to reduce overspray. Overspray is the paint that is sprayed but not deposited on the surface being painted. This equipment not only saves in paint cost, but also reduces volatile organic compound (VOC) emissions and maintenance requirements.

b. Warm the paint before applying, whenever possible. This lowers the paint viscosity enabling spray painting at a lower pressure, thereby minimizing the amount of overspray generated. The lower viscosity also decreases the quantity of solvent used to thin the paint prior to spraying. This results in reduced solvent consumption and VOC emissions.

9-2.1 **Painting Equipment Types.** Spray-painting equipment must conform to national, state, and local emission control requirements. One of these requirements is transfer efficiency. Five primary types of paint spraying equipment and their typical transfer efficiencies include:

1. Conventional air spray (25 percent transfer efficiency).
2. Airless spray (35 percent transfer efficiency).
3. Air-assisted airless spray (45 percent transfer efficiency).
4. Electrostatic spray (65 percent transfer efficiency).
5. High volume/low pressure (HVLP) spray (up to 75 percent transfer efficiency).

9-3 **DESIGN CRITERIA.** Design or procure paint spray booths in accordance with the general technical requirements in Chapter 2 of this UFC and the specific requirements in this Chapter.

9-3.1 **Walk-in Spray Paint Booths.** The ventilation system for a walk-in booth is mainly to prevent fire and explosion. A well-designed ventilation system will also

reduce paint overspray, help control workers' exposure, and protect the paint finish. Workers must use appropriate respiratory protection irrespective of the airflow rate. On 9 February 2000, OSHA issued an interpretation of 29 CFR 1910.94 and 1910.107, *Spray Finishing Using Flammable and Combustible Materials* for determining the airflow rate required for a walk-in paint booth. In accordance with OSHA's interpretation letter, following NFPA 33 will provide protection from fire and explosion. The guidance listed in Subpart Z of 29 CFR 1910.94 provides protection for workers. See Appendix B for OSHA's interpretation.

- a. Use the Painting Operations section in the ACGIH IV manual to determine the design volumetric airflow rate. Ensure that this design volumetric airflow rate will keep the concentration of vapors and mists in the exhaust stream of the ventilation system below the 25 percent of the LEL. See 1910.94(c)(6)(ii) for an example of airflow rate requirement calculations.
- b. Do not re-circulate exhaust air while painting.

9-3.1.1 **Exhaust Configurations.** The two main ventilation system configurations are downdraft and crossdraft. In a downdraft booth, air enters through filters in the ceiling of the booth and leaves through filters that cover trenches under a metal grate floor. In a crossdraft booth, air enters through filters in the front of the booth and leaves through filters in the back of the booth. Both configurations are commercially available.

9-3.1.1.1 **Downdraft Paint Spray Booths.** Downdraft booth configuration provides a cleaner paint job than the crossdraft booth configuration and controls exposures to workers better than crossdraft booth configuration. The downdraft configuration should be the primary choice in designing or selecting of paint spray booths. Figure 9-1 is an example of a downdraft configuration.

9-3.1.1.2 **Crossdraft Paint Spray Booths.** The crossdraft paint spray booth usually requires less total volumetric airflow rate than the downdraft spray paint booth because the vertical cross-sectional area of the booth is often smaller than the booth footprint area. Figures 9-2 and 9-3 are examples of drive-through crossdraft paint spray booth configurations.

Figure 9-1. Walk-in downdraft paint booth.

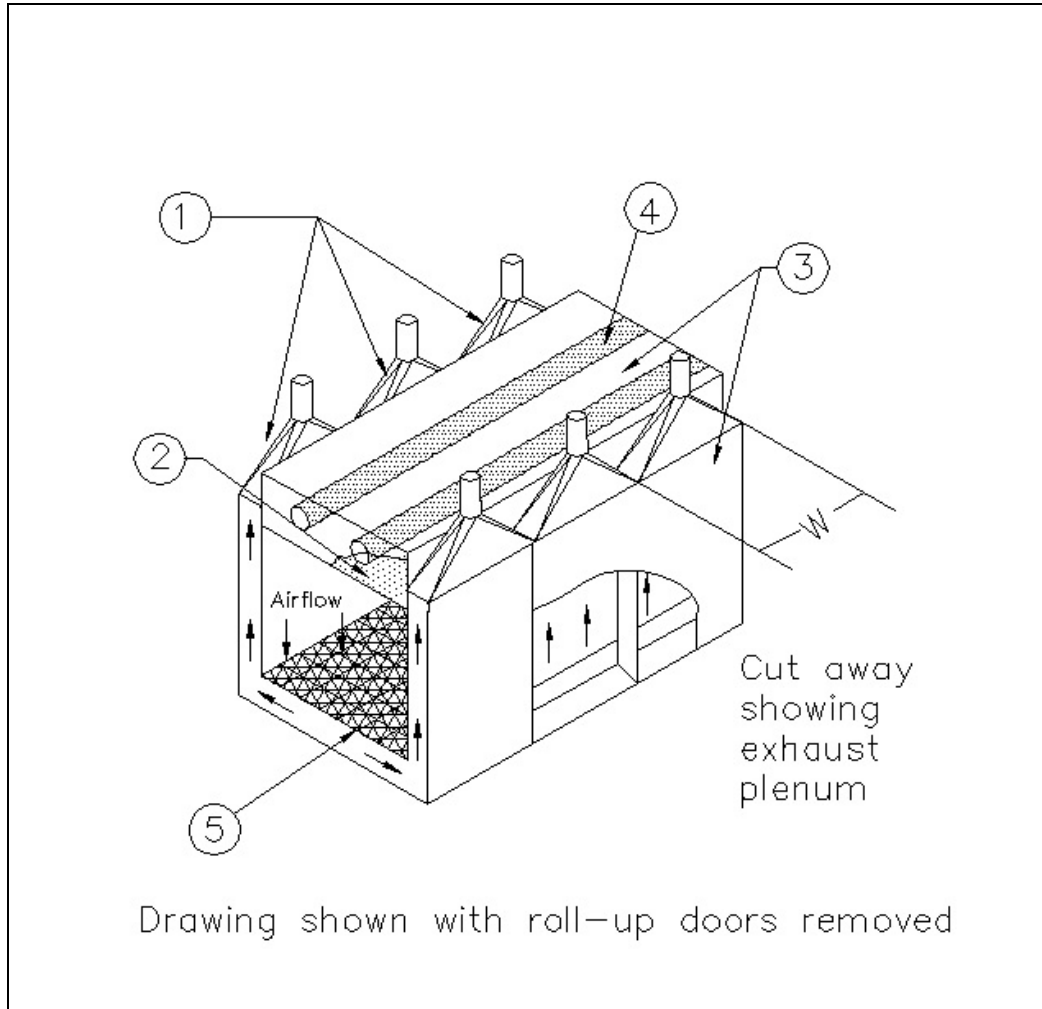

NOTES:

1. Size each plenum take-off for no more than 2.44 m (8 ft) of plenum width (W).
2. Perforated plate with 9.53-mm (3/8-in) holes. Size open area for an airflow velocity of 5.08 m/s (1,000 fpm) through holes.
3. Size exhaust plenum for a maximum plenum velocity of 5.08 m/s (1,000 fpm). Size replacement air plenum for a maximum plenum velocity of 2.54 m/s (500 fpm).
4. Use manufacturer's recommendations for sizing perforated ductwork.
5. Removable filters and floor grating.

Figure 9-2. Drive-through cross draft paint booth with mechanical replacement air.

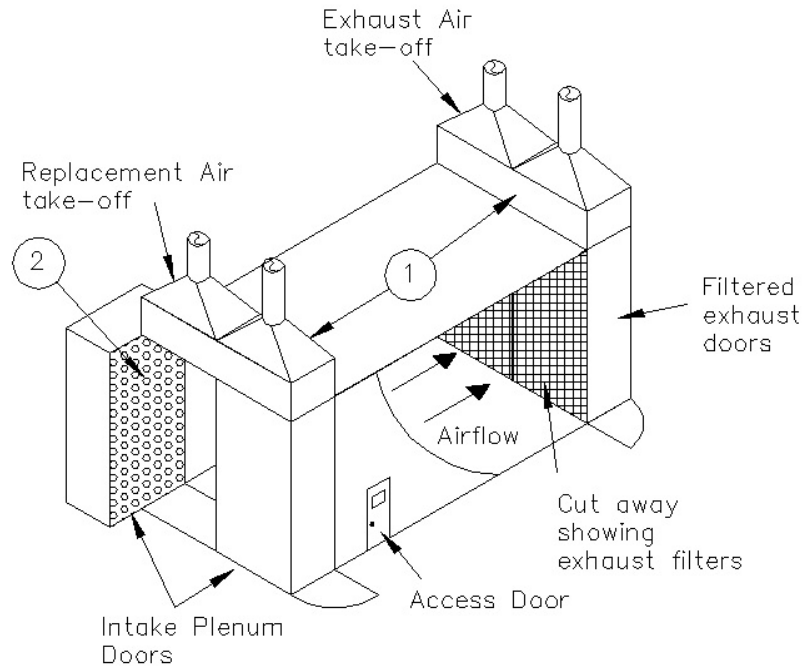

NOTES:

1. Size each plenum take-off for no more than 2.44 m (8 ft) of plenum width. Size the exhaust plenum for a maximum plenum velocity of 5.08 m/s (1,000 fpm). Size replacement air plenum for a maximum plenum velocity of 2.54 m/s (500 fpm).
2. Perforated plate with 9.53-mm (3/8-in) holes. Size open area for an airflow velocity of 10.16 m/s (2,000 fpm) through holes.

Figure 9-3 Drive-through crossdraft paint booth with no Mechanical replacement air

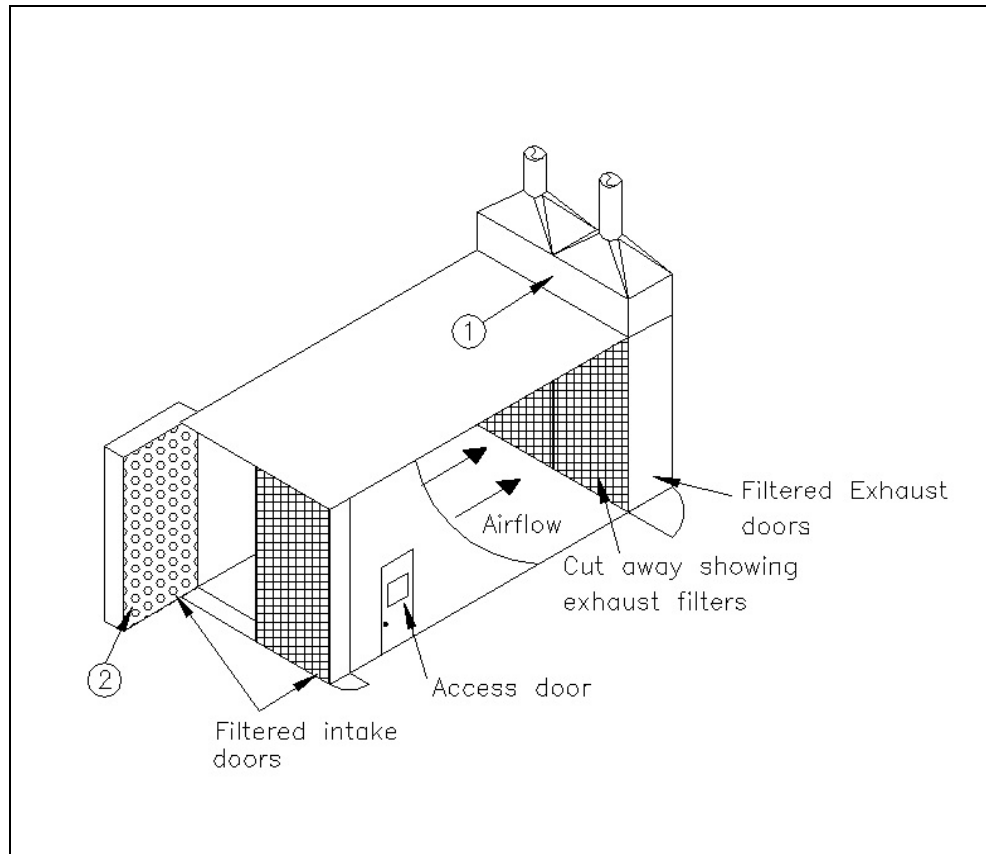

NOTES:

1. Size each plenum take-off for no more than 2.44 m (8 ft) of plenum width. Size the exhaust plenum for a maximum plenum velocity of 5.08 m/s (1,000 fpm). Size replacement air plenum for a maximum plenum velocity of 2.54 m/s (500 fpm).
2. Perforated plate with 9.53-mm (3/8-in) holes. Size open area for an airflow velocity of 10.16 m/s (2,000 fpm) through holes.

9-3.1.2 Paint Spray Booth Exhaust Filtration System. There are two types of exhaust air filtration systems. The first type is a water wash system. A water curtain is created at the exhaust plenum by a pump providing continuous circulation of water. The second type is a dry filter system, where the exhaust air passes through filter media. Consider the following.

- a. Do not design or purchase the water wash paint spray booths. The water wash system requires more energy to operate than the dry filter system. The wastewater must be treated and the hazardous constituents removed (often at great cost to the generating facility) before it may be discharged to a municipal treatment plant.

b. Neither water wash nor dry filter filtration systems can reduce the concentration of volatile organic compounds in the exhaust air stream. Consult the environmental department for controlling volatile organic compounds.

9-3.2 **Storage and Mixing Room.** Refer to the ACGIH IV Manual, Paint Mix Storage Room, VS-75-30 for the design of ventilation system.

9-3.3 **Paint Mix Hoods.** Figure 9-4 is an example of a workbench and a floor hood designed for paint mixing. Provide $0.5 \text{ m}^3/\text{s}$ per m^2 (100 cfm per square foot) of hood face.

Figure 9-4 Paint mixing hood and work bench

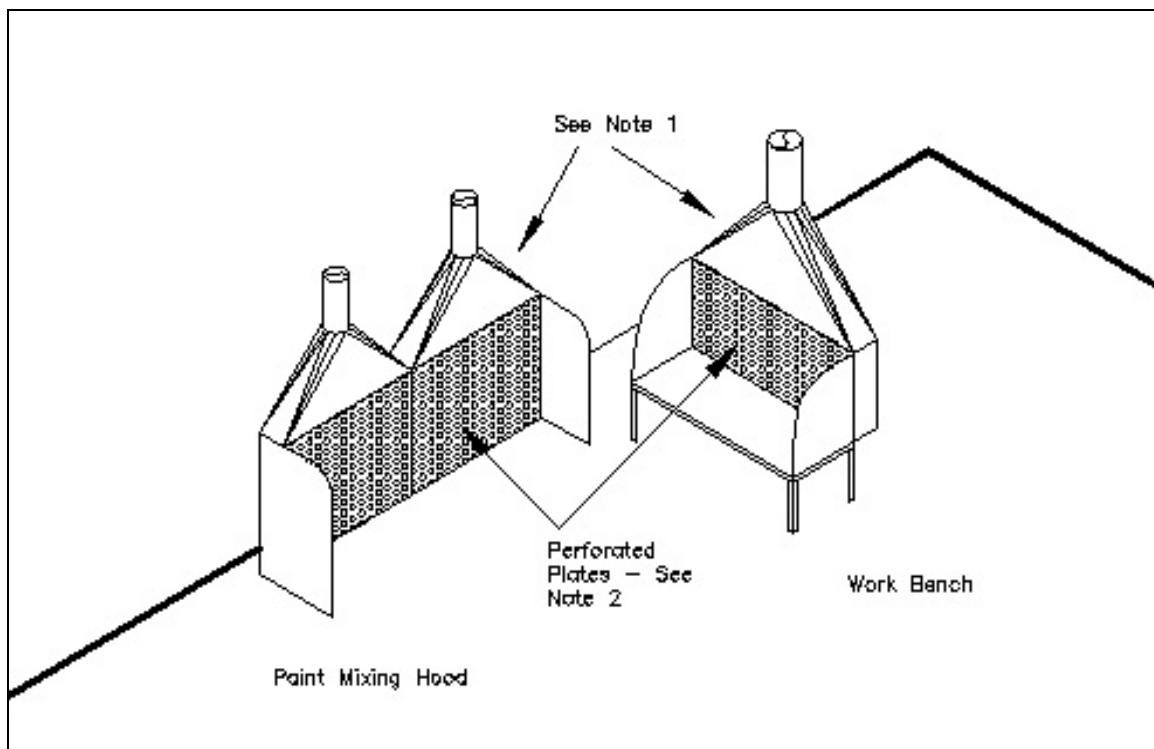

NOTES:

1. Size each plenum take-off for no more than 2.44 m (8 ft) of plenum width. Size each plenum for a maximum plenum velocity of 5.08 m/s (1,000 fpm).
2. Perforated plate with 9.53 mm (3/8-in) holes. Size open area for an airflow velocity of 10.16 m/s (2,000 fpm) through holes.

9-4 **FANS AND MOTORS.** Use explosion proof motor and electrical fixtures for exhaust fan. Do not place electric motors, which drive exhaust fans, inside booths or ducts. See 4-4.2 for more detailed information about fan selection.

9-5 **REPLACEMENT AIR.** There is no control over the room temperature or room static pressure for non-mechanical replacement air systems. Dust from outside

often enters the paint spray booths through cracks and damages the paint finish. Therefore, provide a mechanical replacement air system to maintain a neutral air pressure inside the booth. This will prevent dust from entering the paint spray area. The neutral air pressure will also prevent paint overspray and vapors from escaping the booth and migrating into adjacent work areas. For paint mixing room replacement air, refer to the ACGIH IV Manual, Paint Mix Storage Room, VS-75-30.

9-5.1 **Air Distribution.** Distribution of replacement air within the spray booth is as significant as the average air velocity through the booth. Distribute the replacement air evenly over the entire cross section of the booth to prevent turbulence or undesirable air circulation. The preferred means of distributing the replacement air is through perforated plate as shown in Figures 9-1, 9-2, and 9-3. See paragraph 2-4.5 for additional replacement air design criteria.

9-5.2 **Heating and Air Conditioning.** See paragraph 2-4.5. Most new paint spray booth ventilation systems have a painting mode and a curing mode. Do not re-circulate air during the painting mode. About 10 percent of the booth airflow is from outside the booth and 90 percent of the exhaust air is recycled during curing. Review the paint drying requirements before specifying temperature and humidity ranges. Refer to ANSI Z9.7 for exhaust air re-circulation requirements.

9-6 **SYSTEM CONTROLS.** Design system controls in accordance with paragraph 2-5.

9-7 **RESPIRATORY PROTECTION.** See paragraph 2-7.3.

CHAPTER 10

AIRCRAFT CORROSION CONTROL HANGARS

10-1 **FUNCTION.** Aircraft corrosion control hangars provide space and equipment for the corrosion control processing of aircraft. Processes include: deicing, limited detergent washing and rinsing, paint stripping, corrosion removal, protective coating application and painting, and finish curing and drying.

10-2 **OPERATIONAL CONSIDERATIONS.** See paragraph 9-2 for spray paint operation considerations.

10-3 **DESIGN CRITERIA.** Design hangars in accordance with MIL-HDBK-1028/1, *Aircraft Maintenance Facilities* and the specific ventilation system design requirements in this Chapter.

10-3.1 **Exhaust Air System.** The ventilation system for an aircraft corrosion control hangar is mainly to prevent fire and explosion. A well-designed ventilation system will also reduce paint overspray, help control workers' contaminant exposure, and protect the paint finish. Workers must use appropriate respiratory protection irrespective of the airflow rate. On 8 April 1997 and 1 July 1999, OSHA issued interpretations of 29 CFR 1910.94 and 1910.107 for determining the airflow rate required for an aircraft corrosion control hangars. In accordance with OSHA's interpretation letters, see Appendix D, an aircraft corrosion control hangar must minimally comply with the requirements of NFPA 33 and with Subpart Z of 29 CFR 1910 for hazardous substances.

NOTE U. S. Army: Army facilities will be designed to the requirements of 29 CFR 1910.94 and 1910.106 as well as NFPA33 and Subpart Z of 29 CFR 1910.

10-3.1.1 **Painting Mode.** Design the volumetric airflow rate to keep the concentration of vapors and mists in the exhaust stream of the ventilation system below the 25 percent of the LEL. See 29CFR1910.94(c)(6)(ii) for an example of airflow rate requirement calculations. However, this calculated airflow rate often is too low to capture the paint overspray. Do not re-circulate exhaust air while painting.

NOTE U. S. Army and U.S Air Force: Recirculation of exhaust air may be considered provided requirements of ANSI Z9.7, NFPA 33, ASHRAE, and OSHA are met.

10-3.1.2 **Drying Mode.** Review the paint drying requirements before specifying temperature and humidity ranges. Consider maintaining the airflow rate at the same level as in the painting mode for the simplicity of the system. However, a lower ventilation airflow rate can be used for the drying mode to conserve energy. Recirculation of exhaust air can be used if sufficient outside air is provided to keep the concentration of vapors and mists in the exhaust stream of the ventilation system below

the 25 percent of the LEL. Note that the quantity of off gassed vapors is higher early in the drying process, tapering off at the end of the drying cycle. Refer to ANSI Z9.7 for exhaust air re-circulation requirement.

10-3.1.3 **Grinding Mode.** Provide vacuum exhaust grinding tools to remove dust during operations. The grinding process should be controlled separately from the painting and drying processes. When feasible, grinding should be performed in a separate grinding booth.

10-3.2 **Ventilation System Configurations.** Design or specify the entire exhaust air system using criteria for a crossdraft hangar configuration. Figure 10-1 is one method of designing hangar airflow distribution. When considering alternatives to the perforated supply plenum doors, the designs should introduce the make up air in a laminar manner and minimize the creation of dead air pockets. This will help to capture the paint overspray and reduce the possible build up of contaminants.

Figure 10-1. Crossdraft corrosion control hangar.

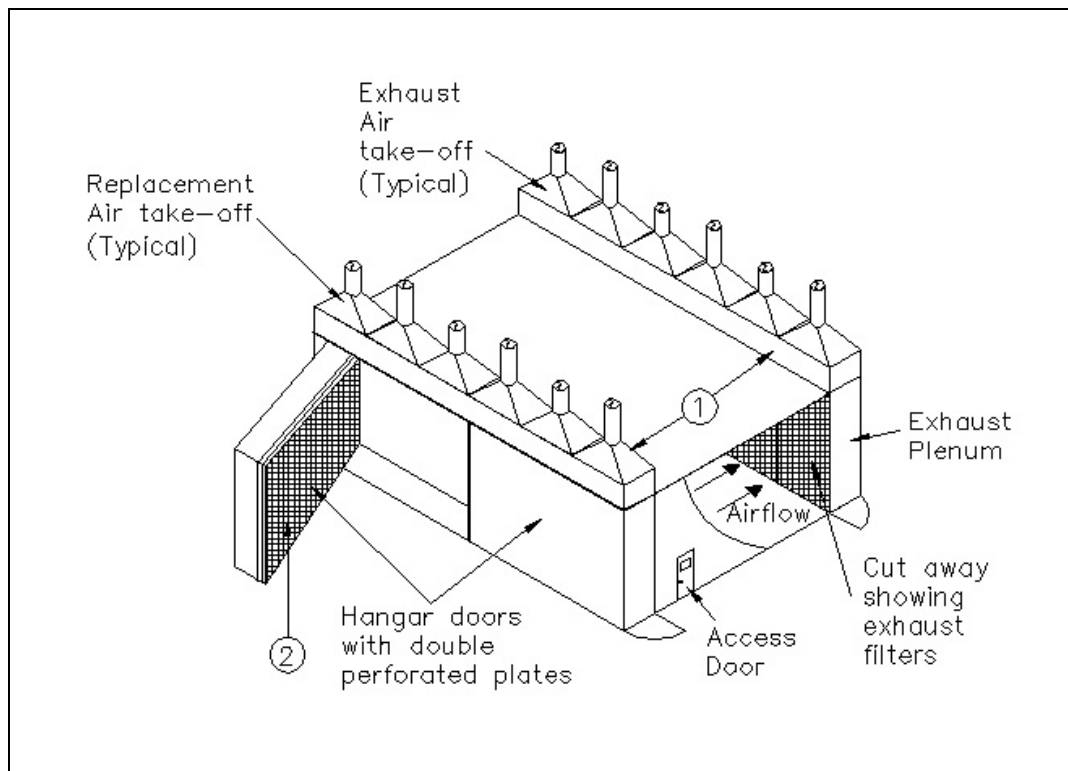

NOTES:

1. Size each plenum take-off for no more than 2.44 m (8 ft) of plenum width (W). Size the exhaust plenum for a maximum plenum velocity of 5.08 m/s (1,000 fpm). Size the replacement air plenum for a maximum plenum velocity of 2.54 m/s (500 fpm).
2. See Figure 10-2 for hangar doors and exhaust plenum details.

Figure 10-2. Hangar door and exhaust plenum details.

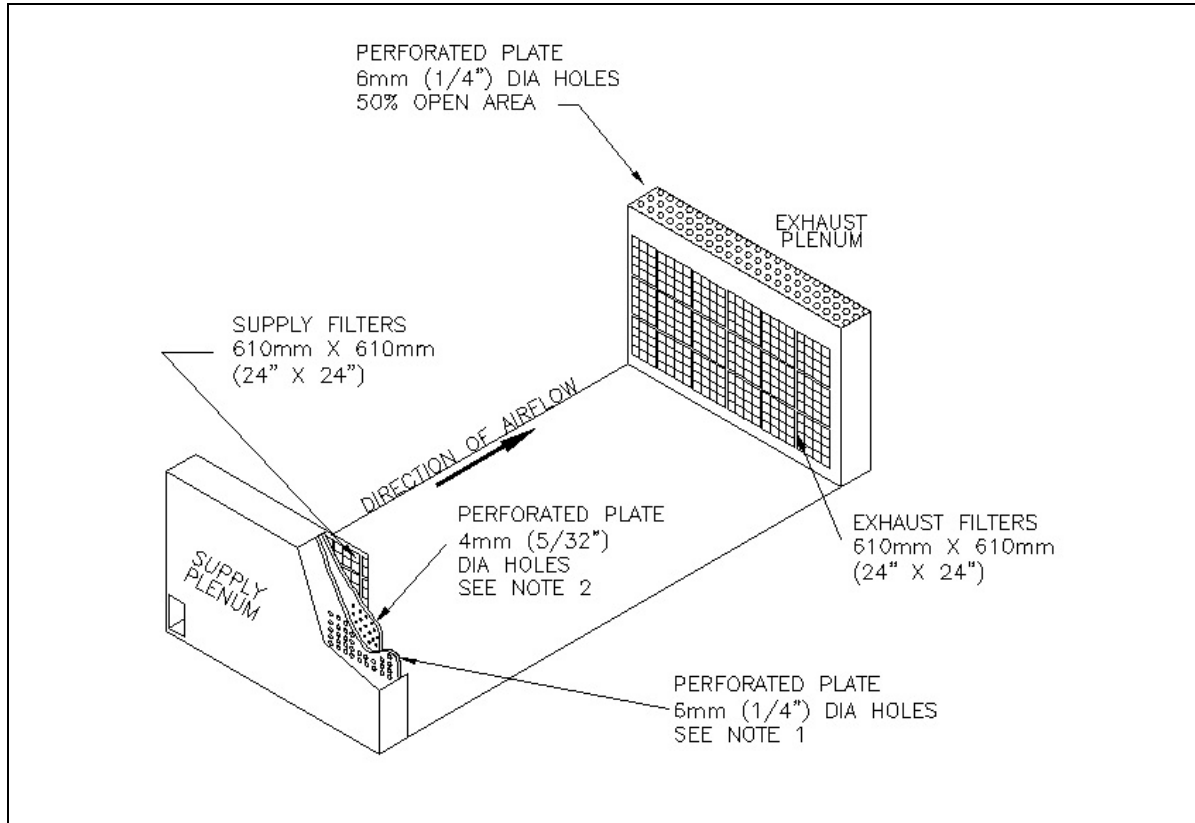

NOTES:

1. Size open area for an airflow velocity of 10.16 m/s (2,000 fpm) through holes.
2. Size open area for an airflow velocity of between 3 to 3.5 m/s (600 to 700 fpm) through holes.

10-3.3 **Exhaust Filtration System.** See paragraph 9-3.1.2

10-3.4 **Auxiliary Walk-in Paint Spray Room.** See Chapter 9 for a paint spray room design.

10-3.5 **Storage and Mixing Room.** Refer to the ACGIH IV Manual, Paint Mix Storage Room, VS-75-30 for ventilation system design.

10-3.6 **Paint Mixing Hood.** See paragraph 9-3.3.

10-4 **FANS AND MOTORS.** Use explosion proof motor and electrical fixtures for exhaust fan. Do not place electric motors, which drive exhaust fans, inside hangars or ducts. See paragraph 2-4.2 for more detailed information about selecting a fan.

10-5 **REPLACEMENT AIR.** Design the replacement air system to maintain a neutral air pressure inside the hangar. This will prevent dust from entering the paint

spray area or paint overspray and vapors from escaping and migrating into adjacent work areas. See paragraph 2-4.5 for detailed design criteria.

NOTE U. S. Army and U.S. Air Force: Design the replacement air system at Army facilities to maintain a slightly negative air pressure inside the hangar.

10-5.1 **Heating and Air Conditioning.** See paragraph 2-4.5.

10-6 **SYSTEMS CONTROLS.** Design system controls in accordance with paragraph 2-5.

10-7 **RESPIRATORY PROTECTION.** See paragraph 2-7.3.

GLOSSARY

Air cleaner	A device designed for the purpose of removing atmospheric airborne impurities such as dusts, gases, vapors, fumes, and smoke. (Air cleaners include air washers, air filters, electrostatic precipitators and charcoal filters.)
Air filter	An air cleaning device to remove light particulate loadings from normal atmospheric air before introduction into the building. Usual range: loadings up to 0.0069 g/m ³ (3 grains per thousand ft ³). Note: Atmospheric air in heavy industrial areas and in-plant air in many collectors are then indicated for proper air cleaning.
Air, standard	Dry air at 70 degrees F, 21.11 degrees C, and 29.92 in. Hg barometer. This is substantially equivalent to 0.075 pounds per cubic feet (lb/ft ³). Specific heat of dry air = 0.24 Btu/lb-F (1.004 kJ/(kg.K)).
Aspect ratio (AR)	Ratio of the width to the length; AR = W/L.
Blast gate	Sliding damper.
Capture velocity	Air velocity at any point in front of the hood or at the hood opening necessary to overcome opposing air currents and to capture the contaminated air at that point by causing it to flow into the hood.
Dust	Small solid particles created by the breaking up of larger particles by processes crushing, grinding, frilling, explosions, etc. Dust particles already in existence in a mixture of materials may escape into the air through such operations as shoveling, conveying, screening, and sweeping.
Dust collector	Air cleaning device to remove heavy particulate loadings from exhaust systems before discharge to outdoors. Usual range: loadings 0.003 grains per cubic foot and higher.
Fan class	This term applies to the fan's performance abilities. The required fan class is determined according to the operating point of the ventilation system. AMCA 99-2408 provides a set of five minimum performance limit standards (Class I through V) which manufacturers use to apply the correct class to their fans.

FRP	Fiberglass reinforced plastic used in construction of such items as boats and airplanes. It is also used for ductwork in corrosive environments.
Fumes	Small, solid particles formed by the condensation of vapors of solid materials.
Gases	Formless fluids which tend to occupy an entire space uniformly at ordinary temperatures and pressures.
Gravity, specific	Ratio of the mass of a unit volume of a substance to the mass of the same volume of a standard substance at a standard temperature. Water at 39.2 degrees F is the standard substance usually referred to for gases, dry air, at the same temperature and pressure as the gas is often taken as the standard substance.
Hood	A shaped inlet designed to capture contaminated air and conduct it into the exhaust duct system.
Humidity, relative	Ratio of the actual partial pressure of the water vapor in a space to the saturation pressure of pure water at the same temperature.
Lower explosive limit (LEL)	Lower limit of flammability or explosiveness of a gas or vapor at ordinary ambient temperatures expressed in percent of the gas or vapor in air by volume. This limit is assumed constant for temperatures up to 250 degrees F. Above these temperatures, it should be decreased by a factor of 0.7 since explosiveness increases with higher temperatures.
Manometer	An instrument for measuring pressure; essentially a U-tube partially filled with a liquid, usually water, mercury or a light oil, so constructed that the amount of displacement of the liquid indicates the pressure being exerted in the instrument.
Micron	A unit of length; the thousandth part of 1 millimeter or the millionth of a meter (approximately 1/25,000 of an inch).
Mists	Small droplets of materials that are ordinarily liquid at normal temperature and pressure.
Plenum	A pressure equalizing chamber.

Pressure, static	Potential pressure exerted in all directions by a fluid at rest. For a fluid in motion, it is measured in a direction normal to the direction of flow. Usually expressed in inches water gauge when dealing with air. (The tendency to either burst or collapse the pipe.)
Pressure, total	The algebraic sum of the velocity pressure and the static pressure (with due regard to sign).
Replacement air	Ventilation term used to indicate the volume of controlled outdoor air supplied to a building to replace air being exhausted.
Slot velocity	Linear flow rate of contaminated air through a slot. Usually measured in meters per second (m/s) [feet per minute (fpm)].
Smoke	An air suspension (aerosol) of particles, usually not solid, often originating in a solid nucleus, formed from combustion or sublimation.
Threshold limit values (TLV)	Values, established by ACGIH, for airborne toxic materials are used as guides in the control of health hazards and represent time-weighted concentrations to which nearly all workers may be exposed 8 hours per day over extended periods of time without adverse effects.
Transport (conveying))	Minimum air velocity required to move the particulates in the air stream, measured in m/s (fpm).
Vapor	The gaseous form of substances which are normally in the solid or liquid state and which can be changed to these states either by increasing the pressure or decreasing the temperature.
Work piece	Equipment or machinery that, while operating, generates a fume, gas, vapor, or particulate hazardous to the health of the operator. Parts washers, wood saws, and degrease units are work pieces.

ABBREVIATIONS AND ACRONYMS

A

ACGIH	American Conference Of Governmental Industrial Hygienists, Inc.
ACH	air changes per hour
AMCA	Air Movement and Control Association, Inc.
ANSI	American National Standards Institute, Inc.
AR	Aspect ratio
ASHRAE	American Society of Heating, Refrigeration And Air Conditioning Engineers, Inc.

C

C	Degrees Celsius
cfh	cubic feet per hour
cfm	cubic feet per minute
cfm/ft ²	cubic feet per minute per square foot
CFR	Code of Federal Regulations
cm	centimeter
cms	cubic meters per second

D

D	depth
dbA	decibels on the A-weighted scale
dM	Design Manual

F

F	Degrees Fahrenheit
fpm	feet per minute
FRP	fiberglass reinforced plastic

G

GSSDC	Guide for steel stack design and construction
-------	---

H

H	Height
HEPA	high efficiency particulate air
HVAC	Heating, ventilation, and air conditioning
HVLP	High volume, low pressure

I

IMC International Mechanical Code
IV Industrial ventilation

L

LEL Lower Explosive Limit
LVHV low volume, high velocity

M

m meter
MEC minimum explosive concentration
MIL-HDBK Military Handbook
MIL-STD Military Standard
mm millimeter
m/s meter per second
MSDS Material Safety Data Sheet

N

NAVAIR Naval Air System Command
NAVFAC Naval Facilities Engineering Command
NFPA National Fire Protection Association
NICAD nickel-cadmium
NIOSH National Institute of Occupational Safety and Health

O

O/I organization and intermediate
OPNAVINST Chief of Naval Operations Instruction
OSHA Occupational Safety and Health Administration

P

Pa Pascal
PEL permissible exposure limit
PPE personal protective equipment
PVC polyvinyl chloride

R

REO Regional Engineering Office
RIDCS Round industrial duct construction standard

S

SCBA self-contained breathing apparatus
SMACNA Sheet Metal And Air Conditioning Contractors National Association

T

TLV Threshold Limit Value
TM Technical Manual
TWA time-weighted average

V

VFD variable frequency drive
VOC Volatile Organic Compound

W

W width
wg water gage

APPENDIX A

REFERENCES

GOVERNMENT PUBLICATIONS:

1. DEPARTMENT OF DEFENSE
<http://dod.wbdg.org/>
UFC 3-420-01, Design: Plumbing Systems
UFC 3-450-01, Design: Noise and Vibration Control
UFC 3-600-01, Design: Fire Protection Engineering For Facilities
UFC 4-216-02N, Design: Maintenance Facilities for Ammunition, Explosives, and Toxins
2. Department of the Navy
<http://neds.nebt.daps.mil.usndirs.htm>
OPNAVINST 5100.23, Navy Occupational Safety and Health Program Manual
3. Naval Sea Systems Command
www.navsea.navy.mil
NAVSEA OP5, Volume 1, Ammunition and Explosives Ashore Safety Regulations for Handling, Storing, Production, Renovation, and Shipping
NAVSEA S6340-AA-MMA-010, Otto Fuel II Safety, Storage, and Handling Instructions
4. Naval Facilities Engineering Command
Engineering Innovation and Criteria Office
6506 Hampton Blvd,
Norfolk, VA 23508
<http://dod.wbdg.org/>
DM 28.4, General Maintenance Facilities
MIL-HDBK-1003/3, Heating, Ventilating, Air Conditioning, and Humidifying Systems
MIL-HDBK-1004/6, Lightning (and Cathodic) Protection
MIL-HDBK-1028/1A, Aircraft Maintenance Facilities
P-970, Protection Planning in the Noise Environment
5. U.S. Department of Labor
Occupational Safety and Health Administration
www.osha.gov
DHEW 79-117, NIOSH Industrial Noise Control Manual
29 CFR 1919.94(a), Abrasive Blasting

29 CFR 1910.94(c), Spray Finishing
Operation

29 CFR 1910.107, Spray Finishing Using
Flammable and Combustible Materials

29 CFR 1910.134, Respiratory Protection

29 CFR 1910.1000, Air Contaminants

29 CFR 1910.1001, Asbestos, General
Industry

29 CFR 1915.1001, Asbestos, Shipyards

29 CFR 1926.403, Battery Rooms and
Battery Charging

OSHA Pub 3048, Noise Control, A Guide for
Workers and Employees

6. U.S. Environmental Protection
Agency
www.epa.gov

EPA-560-OPTS-86-001, A Guide to
Respiratory Protection for the Asbestos
Abatement Industry

NON-GOVERNMENT PUBLICATIONS

1. Air Movement and Control
Association, Inc.

30 West University Drive
Arlington Heights, IL 60004-1893

www.amca.org

AMCA 201, Fans and Systems

AMCA 99-2408, Operating Limits for
Centrifugal Fans (Performance Classes)

2. American Conference of
Governmental Industrial Hygienists, Inc

1330 Kemper Meadow Dr., Ste 600
Cincinnati, OH 45240

www.acgih.org

ACGIH IV Manual, Industrial Ventilation; A
Manual of Recommended Practice

3. American National Standards
Institute, Inc

ANSI O1.1, Woodworking Machinery, Safety
Requirements

11 West 42nd Street,
New York, NY 10036

www.ansi.org

4. American Society of Heating,
Refrigeration and Air Conditioning
Engineers, Inc

1791 Tullie Circle, N.E.
Atlanta, GA 30329

www.ashrae.org

5. National Fire Protection Association

1 Batterymarch Park
Quincy, MA 02269-9101

ANSI Z9.4, Abrasive-Blasting – Ventilation &
Safe Practices for Fixed Location Enclosures

ANSI Z9.7, Recirculation of Air from
Industrial Process Exhaust Systems

ASHRAE Handbook, Fundamentals

ASHRAE Handbook, HVAC Systems and
Equipment

ASHRAE Standard 52.2, Method of Testing
General Ventilation air Cleaning Devices for
Removal Efficiency by Particle Size

ASHRAE Guideline 1, The HVAC
Commissioning Process

NFPA 33, Standard Spray Application Using
Flammable and Combustible Materials

NFPA 34, Standard for Dipping and Coating
Processes Using Flammable or Combustible
Liquids

NFPA 65, Standard for the Processing and
Finishing of Aluminum

NFPA 68, Guide for Venting Deflagrations

NFPA 69, Standard on Explosion Prevention

NFPA 70, National Electrical Code

NFPA 91, Standard for Exhaust Systems for
Air Conveying of Materials

NFPA 480, Storage, Handling, and
Processing of Magnesium

NFPA 481, Storage, Handling, and
Processing of Titanium

NFPA 482, Storage, Handling, and
Processing Zinc

NFPA 485, Storage, Handling and
Processing Lithium

NFPA 650, Pneumatic Conveying Systems
for Handling Combustible Particulate Solids

NFPA 654, Standard for the Prevention of
Fire and Dust Explosions from the
Manufacturing, Processing, and Handling of
Combustible Particulate Solids

NFPA 664, Prevention of Fires and
Explosions in Wood Processing and
Woodworking Facilities

6. Sheet Metal and Air Conditioning
Contractors National Association

SMACNA
4201 Lafayette Center Dr.
Chantilly, VA 20151-1209

SMACNA GSSDC, Guide for Steel Stack
Design and Construction

SMACNA RIDCS, Round Industrial Duct
Construction Standards

SMACNA RTIDCS, Rectangular Duct
Construction Standards

7. Compressed Gas Association

4221 Walney Road, 5th Floor
Chantilly, VA 20151-2923
703-788-2700 (fax) 703-961-1831
cga@cga.com
www.cganet.com

G-7.1, Commodity Specification for Air

APPENDIX B

LETTERS RELATED TO AIRFLOW REQUIREMENTS FOR WALK-IN SPRAY PAINT BOOTHS

B-1 **SCOPE.** This Appendix contains NFESC's letter requesting OSHA interpret ventilation rates for walk-in spray paint booths. See Figure B-1. This Appendix also contains OSHA's response to NFESC's request. See Figure B-2.

Figure B-1. NFESC's letter to OSHA.



DEPARTMENT OF THE NAVY

NAVAL FACILITIES ENGINEERING SERVICE CENTER
1100 23RD AVE
PORT HUENEME CA 93043-4370

50907 NAVY FORM NO. 1
ESC425
6 Jan 1999

From: Commanding Officer, Naval Facilities Engineering Service Center, Port Huenebne
To: Office of Federal Agency Programs, 200 Constitution Avenue N.W.,
Room N3112, Washington DC 20210 (Director/Mr. John E. Plummer)

Subj: VENTILATION RATE FOR FULLY ENCLOSED WALK-IN PAINT
BOOTH/ROOM

1. The Naval Facilities Engineering Service Center and other Navy engineering organizations are currently evaluating designs for several walk-in spray paint booths/rooms. Typical Navy walk-in spray booth/rooms are used for maintaining paint finishes on such items as: vehicles, small boats, antenna towers, aircraft carrier anchor chains, and other small parts from ships and aircraft.
2. These booth/rooms are fully enclosed and the worker stands inside. Industrial ventilation for these systems can be defined as dilution ventilation, since the painter works within the contaminated area and is not isolated from the contaminated air stream. When Navy employees use the walk-in spray paint booth/rooms, they are fully trained in the hazards to which they are exposed, escape routes, fire protection plans, health requirements and the use of personnel protective equipment (PPE).
3. Airflow requirements for Navy designs of walk-in spray paint booth/rooms are currently determined using 29 CFR 1910.94(c) and 29 CFR 1910.107. However, the listed airflow rates in Table G10 and 29 CFR 1910.107(b)(5)(i) will not ensure that worker exposure remains below the Permissible Exposure Limit/Level. Workers must use appropriate respiratory protection irrespective of the airflow rate.
4. The primary purposes of ventilation in these walk-in spray paint booth/rooms are for fire protection and to provide a quality paint finish. Therefore, the requirements in NFPA 33, Flammable and Combustible Material apply.
5. We request your concurrence with our interpretation that:
 - 1) The minimum ventilation rates in 1910.94(c)(6)(i) (Table G-10) and 1910.107(b)(5)(i) are not applicable to the walk-in paint booth/rooms.
 - 2) A walk-in spray paint booth need only comply with the requirements of NFPA 33 and with subpart Z of 29 CFR 1910 for hazardous substances.
6. We appreciate your prompt attention.

DAVID M. CHAVEZ
NAVOSH Engineering Branch
Naval Facilities Engineering Service Center

Figure B-2. OSHA's interpretation.

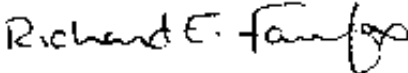
U.S. Department of Labor	Occupational Safety and Health Administration Washington, D.C. 20210	
FEB 9 2000	Reply to the Attention of: DCP/OFAP/RC	
Commanding Officer Naval Facilities Engineering Service Center Naval Occupational Safety and Health - Air (ESC 425) 1100 23 rd Avenue Port Hueneume, CA 93043-4370		
Dear Mr. Chavez:		
Thank you for your faxed letter of January 6, 2000 to the Office of Federal Agency Programs. You have requested our concurrence with your interpretation of the applicability of OSHA standards to the ventilation rate for a fully enclosed walk-in paint booth/room.		
Specifically, you would like OSHA's concurrence that:		
<ol style="list-style-type: none">1) The minimum ventilation rates in 1910.94(c)(6)(i) (Table G-10) and 1910.107(b)(5)(i) are not applicable to the walk-in paint booth/rooms.2) A walk-in spray paint booth need only comply with the requirements of NFPA 33 and with Subpart Z of 29 CFR 1910 for hazardous substances.		
OSHA does not concur with these statements. Both 29 CFR 1910.94(c)(6)(i) (Table G-10) and 1910.107(b)(5)(i) are applicable to walk-in paint booths/rooms. However, if the Navy follows NFPA 33-1995 and 29 CFR Subpart Z, OSHA would consider the lack of compliance with 29 CFR 1910.94(c)(6)(i) (Table G-10) and 1910.107(b)(5)(i) as <i>de minimis</i> violations (a technical violation that is not cited). Following NFPA 33-1995 will provide protection from fire and explosion and the guidance listed in Subpart Z of 29 CFR 1910 will provide protection for your employees.		
Thank you for your interest in occupational safety and health. We hope that you find this information helpful. Please be aware that OSHA's enforcement guidance is subject to periodic review and clarification, amplification, or correction. Such guidance could also be affected by subsequent rulemaking. In the future, should you wish to verify that the guidance provided herein remains current, you may consult OSHA's website at http://www.osha.gov . Should you have further questions, please feel free to contact Mr. John E. Plummer or Mr. Ron Cain of my staff at 202-693-2122.		
Sincerely,		
		
Richard E. Fairfax, Director Directorate of Compliance Programs		

APPENDIX C

LETTERS RELATED TO AIRFLOW REQUIREMENTS FOR CORROSION CONTROL HANGARS

C-1 **SCOPE.** This Appendix contains the NFESC Memorandum (less enclosures 1,2,3 and 4) requesting OSHA interpret the ventilation rates for aircraft corrosion control hangars. See Figure C-1. This Appendix also contains OSHA's response to NFESC's request. See Figure C-2.

Figure C-1. NFESC Memorandum to OSHA

DATE: May 13, 1999

MEMORANDUM

To: Ron Cain, Office of Federal Agency Programs, Occupational Safety and Health Administration, Washington, DC 20210

Via: John Plummer, Director, Office of Federal Agency Programs, Occupational Safety and Health Administration, Washington, DC 20210

From: Kathleen M. Paulson, P.E.
Naval Facilities Engineering Service Center
Naval Occupational Safety and Health - Air (ESC 425),
1100 23rd Avenue
Port Hueneme, CA 93043-4370
Commercial:(805) 982-4984, DSN: 551-4984, FAX:(805) 982-1409
Internet: paulsonkm@nfesc.navy.mil
Web Page: <http://www.nfesc.navy.mil/enviro/esc425/NoshArBr.htm>

SUBJ: INDUSTRIAL VENTILATION FLOW RATES IN AIRCRAFT HANGARS

We appreciate your offer to revisit the OSHA standard interpretation you provided to the Department of the Navy, Office of the Assistant Secretary, (Installations and Environment) regarding spray painting in aircraft hangars. See Enclosures (1) and (2). When we tried to apply the interpretation that you provided to us dated April 8, 1997, we discovered discrepancies in our characterization of the processes performed in Navy Final Finish and Corrosion Control Hangars. Enclosure (3) defines the operations performed in each of the various level hangars.

Our questions are:

1. What is your definition of a production spray finishing operation?
2. How do you characterize the five operational levels of hangars discussed in Enclosure 3?
3. What airflow rate criteria is required for each of the five levels?
4. If 100 cubic feet per minute per square foot of cross-sectional area is required for any of the five operational levels, please define the term cross-sectional area. Is it:
 - a) Area of the exhaust filter bank?
 - b) Area of the exhaust filter bank?

- c) Air envelope around the plane, which excludes the "empty" area where there will be no aircraft parts?
- d) Full opening of the hangar, for instance the approximate side of the hangar door opening plus about 5 feet on the top and sides of the hangar reserved for maneuverability?
- e) Full opening of the hangar including open space for roof trusses?

Naval Facilities Engineering Command (NAVFAC) assigned the NAVOSH Air Branch of NFESC to revise Military Handbook 1003/17, Industrial Ventilation Systems. The handbook defines engineering design criteria for use by all components of the Department of Defense. We are adding a new chapter to the MIL-HDBK discussing the criteria for spray painting in aircraft hangars. We are having difficulties applying the interpretation to our criteria. To add to the urgency, NAVFAC is also in the process of designing several new aircraft hangars. Reducing the flow rate from 100 cubic feet per minute per square foot of cross-sectional area will provide a significant reduction in equipment first costs and annual operating costs.

Our position is - Aircraft hangars should not be designed for 100 cubic feet per minute per square foot of cross-sectional area due to the size of the space and the dilution effect. Regardless of the flow rate, not all the paint overspray will reach the filters and we acknowledge some will drop to the floor. This is particularly true for the portion of the aircraft farthest from the exhaust filter bank. Paint spray criteria in the ACGIH Industrial Ventilation Manual permits airflow in large spaces as low as 50 cubic feet per minute per square foot of cross-sectional area. Both the NFPA 33 and the ANSI Z9.3 consensus standards require a sufficient ventilation rate to prevent vapor build-up by requiring airflow to keep the vapor less than 25% of the LEL. Airflow calculations based on LEL are typically 10-25% of the rates required for health protection. Enclosure (4) reiterates our understanding of the pertinent regulations.

Our experience shows that even in spray painting operations using flow rates of 100 cubic feet per minute per square foot of cross-sectional area, some employee's occupational exposure exceeds the PEL for certain paints and paint components. Therefore, our employees use respiratory protection when painting in hangars.

Thank you for continuing to consider our concern. Based on our phone conversation today, I understand that you are also working on this issue with the US Air Force. Could you direct us to their point of contact? Our contacts are Kappy Paulson and Trinh Do (805) 982-4984.

Figure C-2. OSHA interpretation.

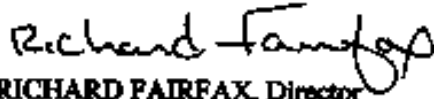
U.S. Department of Labor	Occupational Safety and Health Administration Washington, D.C. 20210	
	Reply to the Attention of:	
JUL 1 1999		
MEMORANDUM FOR:	KATHLEEN M. PAULSON, P.E. NAVOSH Air Branch Naval Facilities Engineering Service Center	
FROM:	 RICHARD FAIRFAX, Director Directorate of Compliance Programs	
SUBJECT:	NFESC e-mail dated May 13, 1999	
<p>This memorandum is in response to your email of May 13, 1999 and confirms subsequent e-mail correspondence between you and Ron Cain of my staff.</p> <p>OSHA considers the Department of Defense corrosion control hangars described in the NFESC memo dated May 13, 1999 as "spray areas." As such, the spray areas must comply with the requirements of NFPA 33, 1995 edition for "Spray Application Using Flammable or Combustible Materials," and with subpart Z of 29 CFR 1910 for hazardous substances. Non-compliance with table G-10 in 29 CFR 1910.94 will be considered <i>de minimis</i> by OSHA as long as the above requirements are met.</p> <p>Should you require further assistance in this or any other matter, feel free to contact John Plummer or Ron Cain of my staff at 202-693-2122.</p>		

NOTE: De Minimis Violations. De minimis violations are violations of standards that have no direct or immediate relationship to safety or health. Whenever de minimis conditions are found during an inspection, they must be documented in the same way as any other violation but would not be included on the citation.